

# Panasonic

Plain Paper Facsimile

Model No. **KX-F3100**



## Operating Instructions

**FOR ASSISTANCE, CALL 1-800-HELP-FAX**

Please read these Operating Instructions before using the unit.

*Thank you for purchasing the Panasonic Plain Paper Facsimile.  
Before using the unit, please read these Operating Instructions completely.  
You can then easily install, configure and operate the unit properly.*

**WARNING:** Do not remove covers and do not repair yourself.  
Refer servicing to qualified personnel.

When you operate this product, the socket outlet should be near the product and be easily accessible.

To prevent fire or shock hazard, do not expose this product to rain or any type of moisture.

**CAUTION:** If ingestion of toner occurs, drink several glasses of water to dilute stomach contents, and seek immediate medical treatment. If eye contact with toner occurs, flush thoroughly with water, and seek medical treatment. If skin contact with toner occurs, wash thoroughly with soap and water.

### ***Important Phone Numbers***

#### ***For United States Only***

Authorized Service Center:	1-800-545-2672
Accessory Purchases:	1-800-332-5368
Technical Support:	1-800-HELP-FAX

(See page 240 for details.)

**IMPORTANT:**

The Telephone Consumer Protection Act of 1991 makes it unlawful for any person to use a computer or other electronic device to send any message via a telephone facsimile machine unless such a message clearly contains in a margin on the top or bottom of, at least, the first sent page the following information:

- 1) Date and time of transmission; and,
- 2) Identification of either business, business entity or individual sending the message; and,
- 3) Telephone number of either the sending machine, business, business entity or individual.

In order to program this information into your facsimile machine, you must complete the steps on pages 43 to 49 in these Operating Instructions.

The serial number of the unit may be found on the label on the rear of the unit. For your convenience, note this number below, and retain this book along with your proof of purchase, to serve as a permanent record of your purchase in the event of a theft, or for future reference.

Model No. \_\_\_\_\_

Name of dealer \_\_\_\_\_

Address of dealer \_\_\_\_\_

Serial No. \_\_\_\_\_  
(found on the rear of the unit)

Date of purchase \_\_\_\_\_

Any details given in these instructions are subject to change without notice.  
The photograph on the cover page may vary slightly from the actual product.

When installing a new battery, the display will show "CHARGING BATTERY" for about 5 hours. At this time, the unit will function properly, but in the event of power interruption, stored documents and voice messages may be lost.



**Chapter 1**

*Installation and Initial Preparation*

---

1

**Chapter 2**

*Basic Instructions*

---

2

**Chapter 3**

*Advanced Instructions*

---

3

**Chapter 4**

*Registration*

---

4

**Chapter 5**

*Troubleshooting and Maintenance*

---

5

**Chapter 6**

*General Information*

---

6

# Table of Contents

---

Page

## *Before Using*

<b>Features</b> .....	<b>8</b>
<b>Receiving Modes</b> .....	<b>9</b>
<b>HELP Function</b> .....	<b>10</b>
<b>Enclosures</b> .....	<b>11</b>
<b>Precaution</b> .....	<b>12</b>
<b>Location of Controls</b> .....	<b>13</b>
Buttons and indicators .....	14

## *Chapter 1 — Installation and Initial Preparation*

<b>Installing the Unit</b> .....	<b>20</b>
Minimum space requirements .....	20
Preparing the toner cartridge .....	20
Installing the drum unit .....	22
Installing the receiving tray .....	24
Installing the document feeder tray .....	25
Installing the paper cassette and loading paper .....	25
Installing the rechargeable battery .....	28
Connecting the cords .....	30
Turning the power switch on .....	31
Setting selectors .....	32
<b>Display Indication</b> .....	<b>33</b>
<b>Recording Your Greeting Messages</b> .....	<b>34</b>
Suggested messages .....	34
How to record your greeting messages .....	34
How to check your greeting messages .....	36
<b>Selecting the Receiving Mode</b> .....	<b>37</b>
<b>Selecting the Paper Size</b> .....	<b>39</b>
<b>System Programming Features</b> .....	<b>40</b>
Basic features .....	40
Advanced features .....	41
Setting date and time .....	43
Setting your logo and facsimile telephone number .....	44
How to use the character keys .....	47

## *Chapter 2 — Basic Instructions*

### *Facsimile*

<b>Transmitting Documents</b> .....	<b>52</b>
Before transmitting documents .....	52
Manual transmission (Case 1) .....	55
Redialing the last dialed number .....	56
Manual transmission (Case 2) .....	57
<b>Receiving Documents</b> .....	<b>58</b>
Manual reception .....	58
Automatic reception .....	59
Receiving over-sized documents .....	62
Memory reception .....	63
<b>Transmitting Documents Manually to Your Unit</b> .....	<b>64</b>
Leaving a message and transmitting documents on the same call .....	64
Transmitting documents with manual operation .....	65
<i>Copier</i>	
<b>Making Copies</b> .....	<b>66</b>

	Page
<i>Telephone Answering Device</i>	
<b>Operating the Answering Device</b> .....	<b>67</b>
Setup of voice message and document reception .....	67
Monitoring incoming calls .....	68
<b>Listening to Recorded Messages</b> .....	<b>69</b>
Listening to newly recorded messages .....	69
Listening to all the recorded messages .....	70
Functions during the message playback .....	70
Listening to the beginning of each recorded message .....	71
Saving messages .....	71
<b>Erasing Recorded Messages</b> .....	<b>72</b>
Erasing specific messages from memory .....	72
Erasing all messages from memory .....	72
<b>Recording a Memo Message</b> .....	<b>73</b>
<b>Recording a Telephone Conversation</b> .....	<b>74</b>
<i>Telephone</i>	
<b>Making and Answering Voice Calls</b> .....	<b>75</b>
Making voice calls .....	75
Redialing the last dialed number .....	77
Answering voice calls .....	77

### *Chapter 3 — Advanced Instructions*

<b>Storing Phone Numbers for Automatic Dialer</b> .....	<b>80</b>
Filling in the directory card .....	80
Storing phone numbers for one-touch dialing .....	81
Storing multistations for one-touch dialing .....	83
Storing phone numbers for speed dialing .....	85
Storing secret phone numbers .....	87
<b>Erasing Stored Phone Numbers</b> .....	<b>89</b>
<b>Printing Stored Phone Number List</b> .....	<b>92</b>
Printing the telephone number list .....	93
<b>Electronic Telephone Directory</b> .....	<b>94</b>
Before using the electronic telephone directory .....	94
How to use the electronic telephone directory .....	95
<i>Facsimile</i>	
<b>Transmitting Documents Using Automatic Dialer</b> .....	<b>97</b>
Using one-touch dialing .....	97
Using the broadcast keys .....	98
Using speed dialing .....	99
Using the electronic telephone directory .....	100
<b>Reserving Transmission while Receiving Documents</b> .....	<b>102</b>
<b>Delayed Transmission</b> .....	<b>103</b>
<b>Polling</b> .....	<b>107</b>
Polling another machine .....	107
Being polled .....	108
Programming the polling passcode .....	110
<b>Multistation Transmission</b> .....	<b>112</b>
Multitransmission report .....	114
<b>Memory Transmission</b> .....	<b>115</b>
Setting the memory transmission .....	115
Transmitting the stored documents .....	116
<b>Mail Box</b> .....	<b>118</b>
Programming the mail box passcode .....	118
Transmitting documents to your mail box .....	120
Retrieving documents in a mail box .....	120
Retrieving documents in a mail box from remote location .....	122

	Page
<b>Network Communication</b> .....	<b>123</b>
Using the network passcode .....	123
Programming the network passcode .....	125
Turning on the transmission passcode check mode .....	126
Turning on the reception passcode check mode .....	127
<b>Forwarding Received Documents</b> .....	<b>128</b>
Fax forwarding report .....	130
Retrieving mis-forwarded documents .....	131
Turning on or off the forwarding feature from a remote location .....	131
<b>Using the TRANSMIT SETTING Button</b> .....	<b>133</b>
Total page number and the special message .....	133
Overseas transmission mode .....	134
Transmitting documents with the TRANSMIT SETTING button .....	134
Programming a personal message .....	136
<i>Telephone Answering Device</i>	
<b>Remote Operations of the Answering Device</b> .....	<b>138</b>
Summary of remote operations .....	138
Programming the remote code .....	139
Playing back newly recorded messages .....	140
Playing back all messages .....	141
Functions during the message playback .....	141
Erasing specific messages from memory .....	142
Erasing all messages from memory .....	142
Recording a remote memo message .....	143
Room monitoring .....	143
Skipping the greeting message .....	144
Re-recording a greeting message .....	144
<i>Telephone</i>	
<b>Making Voice Calls Using Automatic Dialer</b> .....	<b>146</b>
Making voice calls using the electronic telephone directory .....	147
<b>Calling Your Unit with the Privacy Ring</b> .....	<b>148</b>
Calling with the privacy ring .....	148
Changing the privacy ring ID number .....	149
<b>Voice Contact</b> .....	<b>150</b>
Initiating voice contact .....	150
Receiving a request for voice contact .....	151
<b>TONE, FLASH, PAUSE, and MUTE Buttons</b> .....	<b>152</b>
Changing from pulse to tone mode (TONE button) .....	152
Accessing features of your host exchange (FLASH button) .....	152
Inserting a pause into a phone number (PAUSE button) .....	153
Voice muting (MUTE button) .....	154
<i>Reserve Phone</i>	
<b>Reserve Phone</b> .....	<b>155</b>
<b>Remote Fax Receiving Using a Reserve Phone</b> .....	<b>156</b>
Receiving documents by operation of reserve phone .....	156
Changing a remote fax activation code .....	157

#### *Chapter 4 — Registration*

<b>Setting the Individual Transmission Report Printing</b> .....	<b>160</b>
<b>Selecting the Number of Rings in the FAX Mode</b> .....	<b>162</b>
<b>Selecting the Number of Rings in the ANS/FAX Mode</b> .....	<b>163</b>



	Page
<b>Selecting the Caller's Recording Time</b> .....	165
<b>Setting the Logo Print Position</b> .....	166
<b>Setting the Journal Report Printing</b> .....	167
Printing the journal report automatically .....	168
Printing the journal report manually .....	169
<b>Selecting the Number of Fax Recognition Rings</b> .....	170
<b>Setting the Copy Mode</b> .....	171
Setting the reduction or inhibition mode .....	171
Making extension copies .....	173
<b>Setting the Receiving Reduction Mode</b> .....	175
<b>Additional Feature for Distinctive Ring Service</b> .....	177
Programming your unit with distinctive ringing pattern .....	177
<b>Adjusting the Display Contrast</b> .....	179
<b>Setting the Day/Night Mode</b> .....	180
<b>Selecting the Number of Rings of Reserve Phone</b> .....	182
<b>Setting the Transmission Speed</b> .....	184
<b>Setting the Message Alert</b> .....	185
<b>Resetting the System Programming Features</b> .....	186
<b>Printing the System Programming List</b> .....	188

### *Chapter 5 — Troubleshooting and Maintenance*

<b>Troubleshooting</b> .....	192
Error display messages .....	192
Explanation of communication result on the report .....	195
General corrective measures .....	196
Clearing a document jam .....	200
Adjusting the feed pressure .....	201
Clearing a recording paper jam .....	202
<b>If a Power Failure Occurs</b> .....	206
Power-down report .....	206
<b>Maintenance</b> .....	207
Cleaning the cabinet .....	207
Cleaning the document feeder unit .....	207
Cleaning the printer .....	209
Replacing the cleaning pad and the toner cartridge .....	210
Replacing the drum unit .....	216
Replacing the rechargeable battery .....	218
<b>Repacking</b> .....	220

### *Chapter 6 — General Information*

<b>Accessory Order Information</b> .....	228
<b>Specifications</b> .....	229
Main unit specifications .....	229
Paper specifications .....	230
<b>Speed Dial Directory</b> .....	231
<b>Quick Reference Card for Remote Operation</b> .....	233
<b>Index</b> .....	235
<b>FCC Information</b> .....	239
<b>Servicenter Directory</b> .....	240
<b>Fax Correspondence</b> .....	241
<b>Limited Warranty</b> .....	243

# Features

---

## **Multi-function system by using one telephone line**

### **General**

- Compact, vertical design
- Help function (page 10)
- LCD (Liquid Crystal Display) readout (page 33)
- Automatic voice/facsimile switching (page 59)

### **Plain Paper Facsimile Machine**

- 15 second transmission speed\*
- Letter/Legal, G3 compatible
- Automatic document feeder
- 28 station one-touch dialer (page 81)
- 100 station speed dialer (page 85)
- 5 broadcast keys for multistation transmission (page 83)
- Resolution: Standard/Fine/Halftone (32 level) (page 53)
- Contrast: Normal/Light/Darker (page 53)
- Delayed transmission (page 103)
- Polling function (page 107)
- Multistation transmission (page 112)
- Silent ring fax recognition system (page 170)
- Network passcode communication\*\* (page 123)
- Passcode polling\*\* (page 110)
- Fax forwarding function (page 128)
- Customized header (page 133)
- Overseas transmission function (page 134)

\* Transmission times apply to text data by using ITU-T No. 1 test chart, between the same models at maximum modem speed and may vary in actual usage.

\*\*These functions are effective between other compatible facsimile machines that have the same passcode.

Panasonic-compatible facsimile machines are:  
e.g. KX-F90, KX-F110, KX-F130, KX-F150,  
KX-F230, KX-F250

### **Digital Answering Machine**

- Full digital recording
- One-touch message playback (page 69)
- Remote control from touch-tone telephone (page 138)
- Message memo recording (page 73)
- New message playback (page 69)
- Quick message playback (page 71)
- Message scan (page 71)
- Individual message erasing (page 72)

### **Large Memory \*\*\***

- 70 page memory for reception and transmission (pages 63 and 115)
- 5 mail box and remote mail box reception (page 118)

\*\*\*Memory capacity applies to text data by using ITU-T No. 1 test chart in standard resolution.

### **Integrated Telephone System**

- Electronic telephone directory (page 94)
- Speakerphone operation (page 75)
- Voice muting (page 154)
- Redialing function (page 77)
- Temporary tone dialing (page 152)
- Privacy ring function (page 148)

### **Copier Function**

- Extension copy (page 173)
- Multicopier function (page 66)

# Receiving Modes

---

This unit provides the following types of receiving modes. Depending on your situation, select the desired mode.

**ANS/FAX (Answering Device/Facsimile) mode:**

When you wish to use the unit as a telephone answering device and a facsimile, or when your machine is unattended, select this mode. The unit records a voice-message and/or receives a document automatically depending on the caller's choice.

**TEL/FAX (Telephone/Facsimile) mode:**

When you are in the office, and you wish to use the unit as a standard telephone and a facsimile machine, select this mode.

The unit will automatically receive a document when a fax call comes in.

You can use the unit as a standard telephone when you answer a call.

**FAX (Facsimile) mode:**

When you wish to use the unit as a facsimile machine only, select this mode.

When a fax call comes in, the unit will automatically receive a document.

When a voice call comes in, the unit will emit a fax tone to the calling party, and you cannot talk to the other party.

**TEL (Telephone) mode:**

When you wish to use the unit as a standard telephone, select this mode.

If you receive a fax call, you will be able to receive a document manually. Automatic fax reception is not available.

For further details, see page 37.

**NOTES:**

- Making calls and transmitting documents are possible in every receiving mode.
- If you connect a telephone on the same line to which your facsimile unit is connected, see page 155.

## **HELP function**

---

The unit is equipped with the HELP function. Use this function if you lose your instructions while using the unit. It will provide you with instructions.

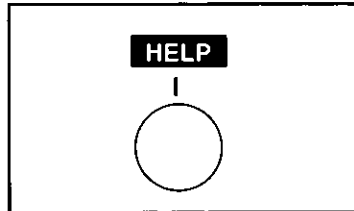

If you press **HELP**:

- While programming, the unit will print the relevant programming instructions.
- In idle status, the unit will print information on how to transmit a document, how to program function, and how to store a phone number, and so on.
- All the HELP lists will be printed out in English.

# Enclosures

After removing the unit from the packing carton, examine the unit for signs of shipping damage and check to make sure that all of the enclosures are included.

Telephone Line Cord ..... 1 pc.

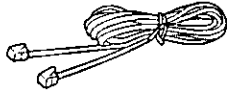

(Page 30)

Handset ..... 1 pc.

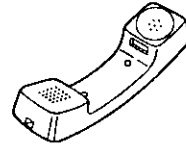

(Page 30)

Power Cord ..... 1 pc.



(Page 30)

Handset Cord ..... 1 pc.

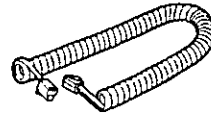

(Page 30)

Receiving Tray ..... 1 pc.

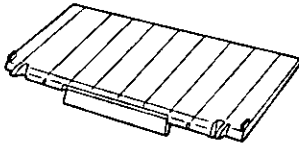

(Page 24)

Document Feeder Tray ..... 1 pc.

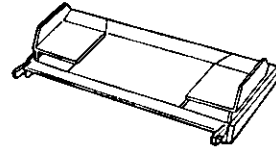

(Page 25)

Extenders ..... 2 pcs.

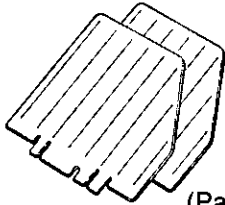

(Pages 24 and 25)

Paper Cassette ..... 1 pc.

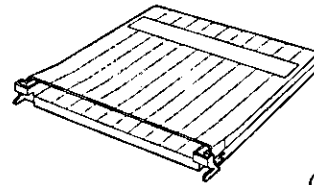

(Page 25)

Drum Unit ..... 1 pc.

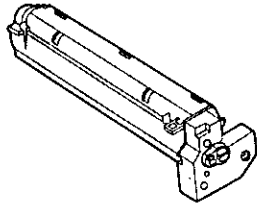

(Page 22)

Storage Bag ..... 1 set  
(Shipping cover bag and sealing tape)

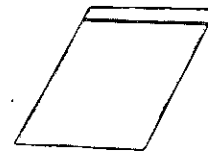

(Pages 20 to 24)

Rechargeable Battery ..... 1 pc.

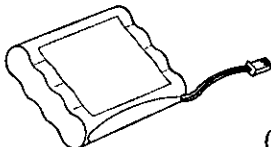

(Page 28)

## NOTES:

- If you are missing any item, consult place of purchase.
- Save the original carton and packing materials for proper shipping and transporting of the unit.
- The toner cartridge is installed in the unit when shipped (see page 20).

# Precaution

## Installation

The unit should be placed on a sturdy and level surface.

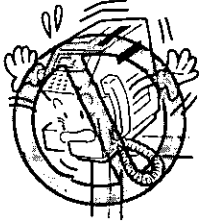

Keep the unit away from heating appliances, such as radiators or air conditioning units.

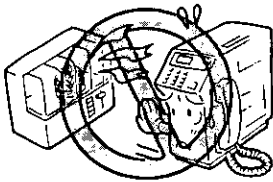

Keep the unit away from electrical noise-generating devices, such as fluorescent lamps and motors.

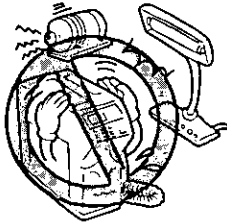

The unit should be kept free from dust, moisture, high temperature, and vibration.

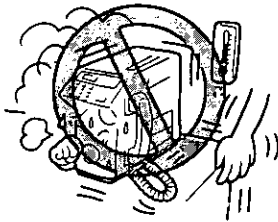

The unit should not be exposed to direct sunlight.

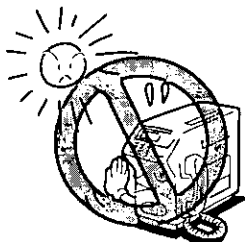

## Handling

Do not allow any foreign matter to enter the interior of the unit, especially metal objects.

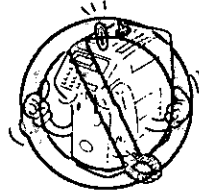

Do not place any covering over the unit while it is turned on.

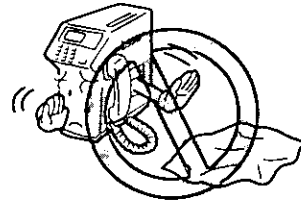

Do not damage the power cord.  
Do not touch the plug with wet hands.

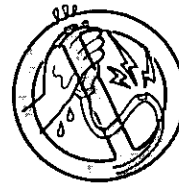

Keep the unit dry. Never operate the unit if liquid has been spilled into it. Immediately unplug the unit, have it inspected by service technician. Fire and shock hazards can result from electrical shorts caused by liquid contact inside.

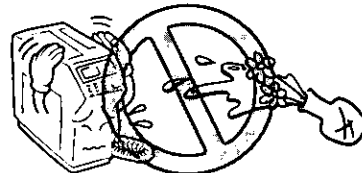

In order to avoid a paper jam, do not open the printer cover while in operation.

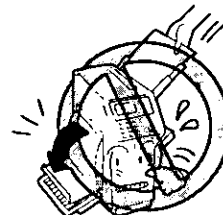

# Location of Controls

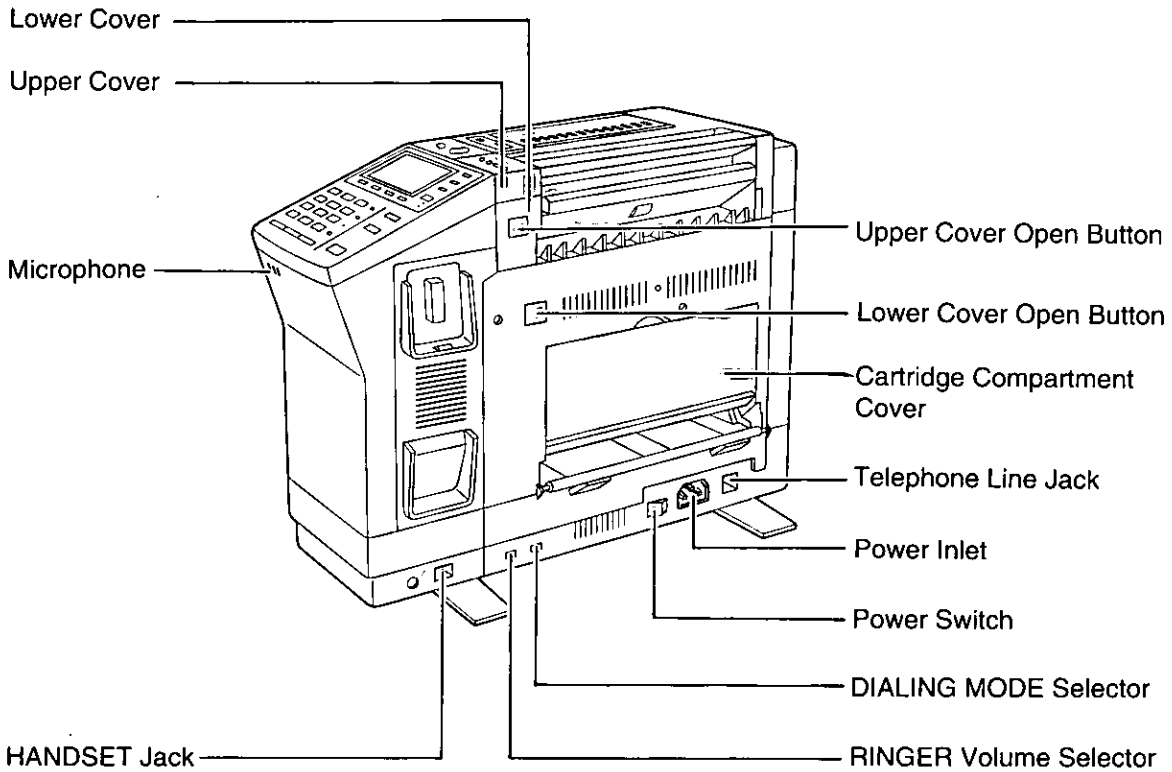
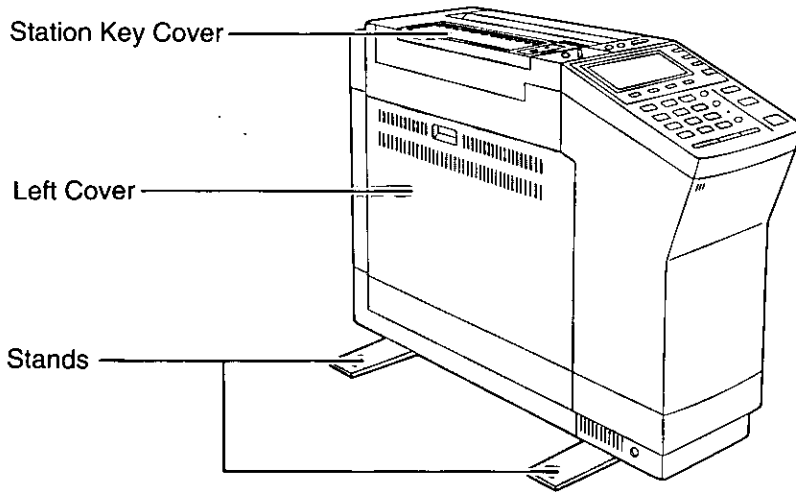

**NOTE:**

- To prevent the unit from falling down, lift the unit slightly and turn the stands to pull out.

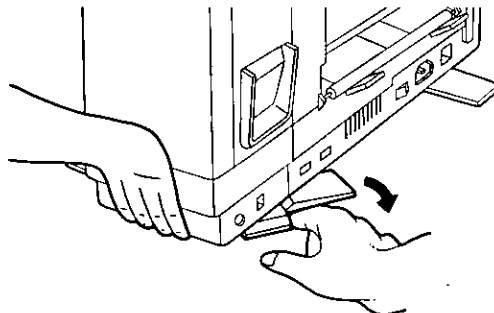

## Buttons and indicators

**VOLUME Control Button**  
(Pages 69 and 76)  
Used to adjust the speaker or handset volume level.

**HELP Button** (Page 10)  
Used to print easy guides of instructions.

**Dial Keypad/Character Keys**  
Used to dial phone numbers or enter parameters while programming.  
Also used to enter characters while programming.

**TONE Button** (Page 152)  
Used to temporarily change the dialing mode from pulse to tone during a dialing operation.

**FLASH Button**  
(Page 152)  
Used to access features of your host private branch exchange.

**REDIAL Button** (Pages 56 and 77)  
Used to redial the last dialed number.

**SP-PHONE/VOICE STDBY Button and Indicator** (Pages 55 and 150)  
Used for speakerphone operation and voice contact functions.

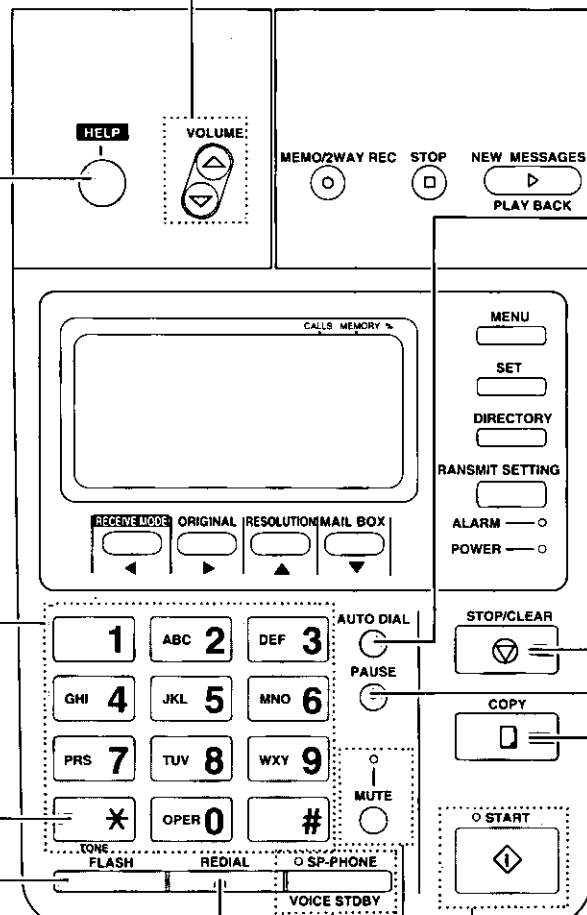

**AUTO DIAL Button**  
(Pages 85 and 99)  
Used for speed dialing.

**STOP/CLEAR Button**  
Used to cancel transmission or copy operation.  
Also used to clear the previously entered parameters while programming.

**PAUSE Button**  
(Page 153)  
Used to insert a pause into a phone number.

**COPY Button** (Page 66)  
Used to start copy function.

**START Button and Indicator**  
Used to start transmission or reception, or to print lists and reports.

**MUTE Button and Indicator**  
(Page 154)  
Used when you do not wish your voice to be heard by the other party.



**STOP Button** (Page 71)

Used to stop operations of the answering device.

**MEMO/2 WAY REC (Recording) Button**

(Pages 73 and 74)

Used to start and stop recording a memo message or a telephone conversation.

**NEW MESSAGES PLAYBACK Button** (Page 69)

Used to play back newly recorded voice-messages.

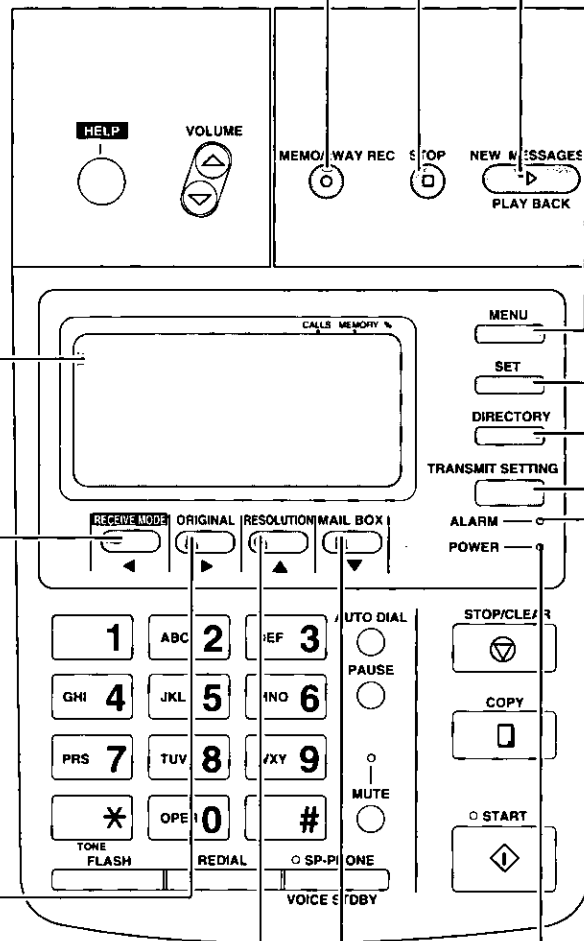

**MENU Button**

Used to start the various programming.

**SET Button**

Used to store parameters while programming.

**DIRECTORY Button**

(Page 95)

Used to dial phone numbers by using the electronic telephone directory.

**TRANSMIT SETTING Button**

(Page 133)

Used to start the transmission setting before transmission.

**ALARM Indicator**

(Page 196)

The indicator light is on when a problem is detected.

**POWER Indicator**

The indicator light is on when the power is on.

**Liquid Crystal Display**

(Page 33)

Provides convenient information.

**RECEIVE MODE Button/**

**◀ Key**

(Pages 37 and 48)

Used to select the desired receiving mode. The display shows the mode in which the unit is set. Also used as the cursor key while programming.

**ORIGINAL Button/ ▶ Key**

(Pages 48 and 53)

Used to select the desired contrast mode to transmit or make copies. The display shows the mode in which the unit is set. Also used as the cursor key while programming.

**RESOLUTION Button/▲ Key**

(Pages 53 and 95)

Used to select the definition. The display shows the mode in which the unit is set. Also used as the cursor key while programming.

**MAIL BOX Button/▼ Key** (Page 118)

Used to store the documents in the mail box of the unit, or program the mail box passcode. Also used as the cursor key while programming.

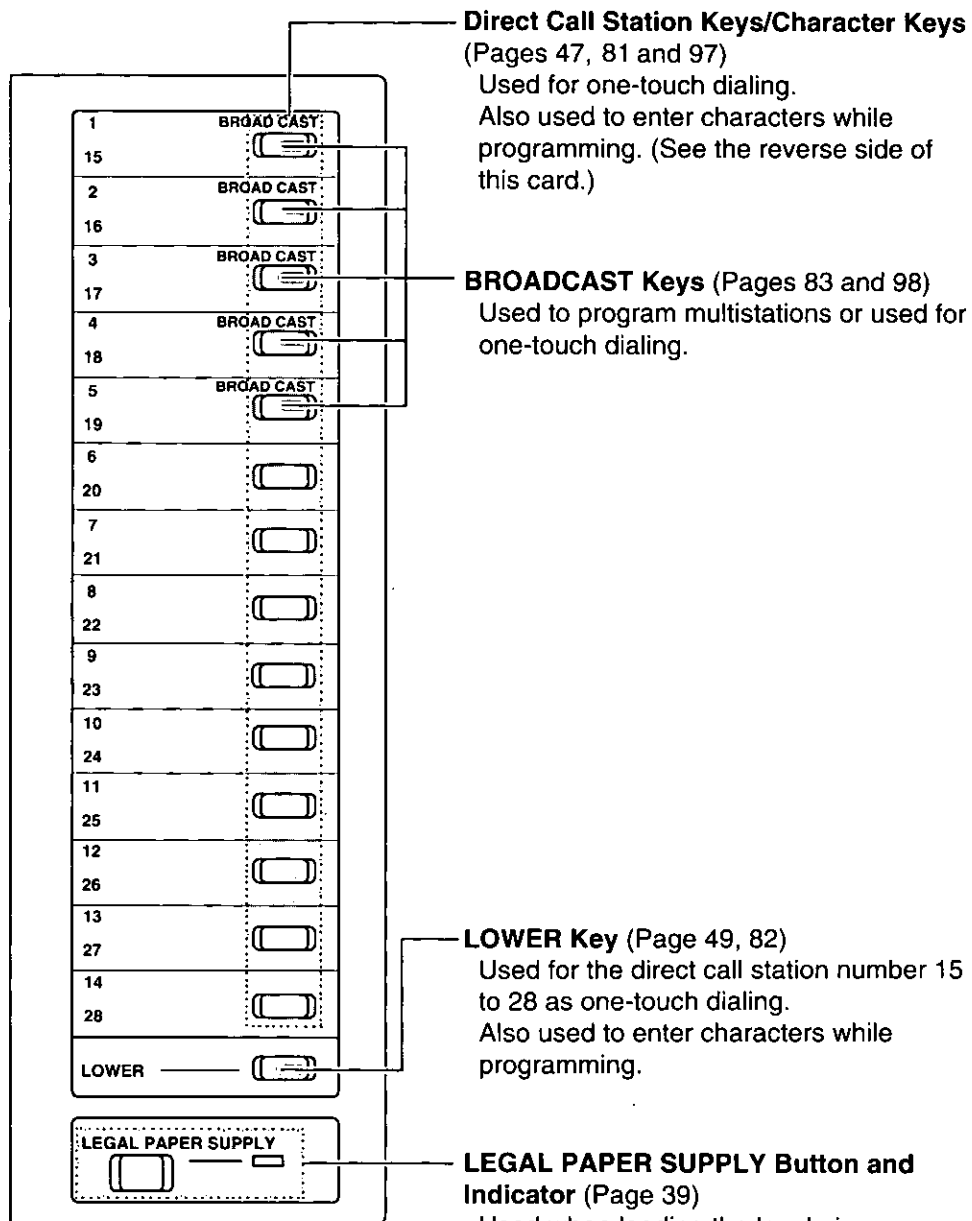

(Front of the station key cover)

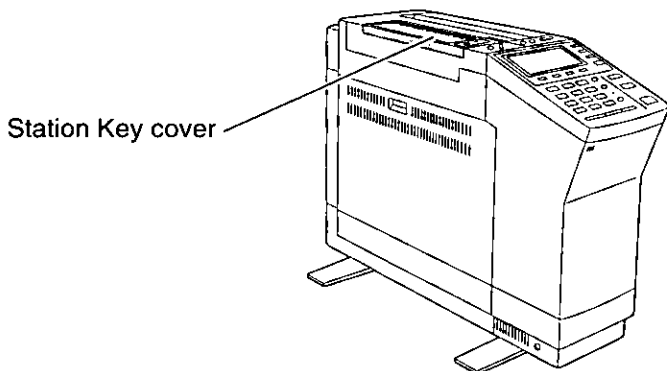

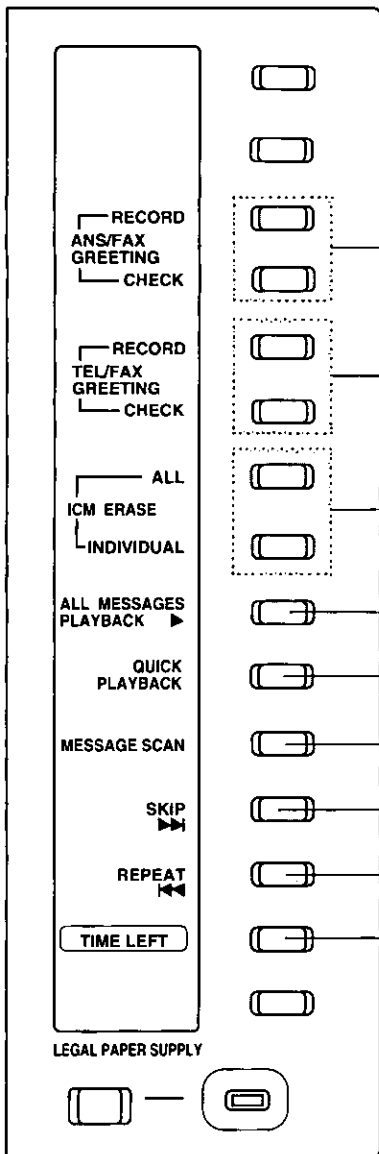

(Inside the station key cover)

**ANS/FAX GREETING RECORD Button** (Page 35)  
Used to start recording your greeting message for the ANS/FAX mode.

**ANS/FAX GREETING CHECK Button** (Page 36)  
Used to play back and check your greeting message for the ANS/FAX mode.

**TEL/FAX GREETING RECORD Button** (Page 35)  
Used to start recording your greeting message for the TEL/FAX mode.

**TEL/FAX GREETING CHECK Button** (Page 36)  
Used to play back and check your greeting message for the TEL/FAX mode.

**ICM (Incoming Message) ERASE-ALL Button** (Page 72)  
Used to erase all recorded incoming voice-messages.

**ICM (Incoming Message) ERASE-INDIVIDUAL Button** (Page 72)  
Used to erase a specific incoming voice-message recorded.

**ALL MESSAGES PLAYBACK (▶) Button** (Page 70)  
Used to play back all recorded voice-messages.

**QUICK PLAYBACK Button** (Page 71)  
Used to play back a recorded voice-message quickly during the message playback.

**MESSAGE SCAN Button** (Page 71).  
Used to play back the beginning of each recorded voice-message.

**SKIP (▶▶) Button** (Page 70)  
Used to skip to the next message during the message playback.

**REPEAT (◀◀) Button** (Page 70)  
Used to replay the previous message during the message playback.

**TIME LEFT Button** (Page 67)  
Used to display the time left for recording voice-messages.



# **Chapter 1**

## *Installation and Initial Preparation*

# Installing the Unit

## Minimum space requirements

The following minimum space requirements allow for the best performance.

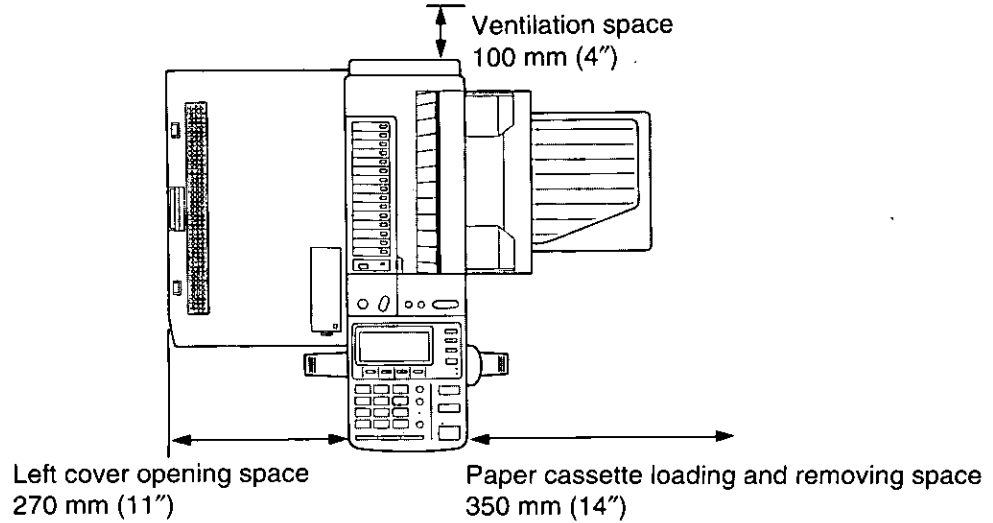

## Preparing the toner cartridge

**CAUTION:**

– If ingestion of toner occurs, drink several glasses of water to dilute stomach contents, and seek immediate medical treatment. If eye contact with toner occurs, flush thoroughly with water, and seek medical treatment.

If skin contact with toner occurs, wash thoroughly with soap and water.

1

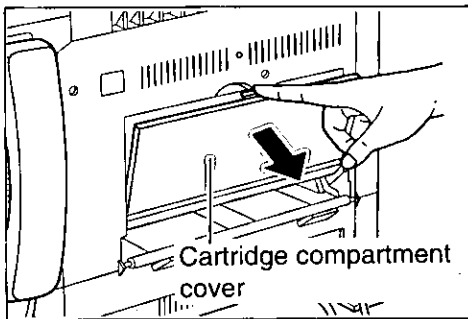

Open the cartridge compartment cover.

2

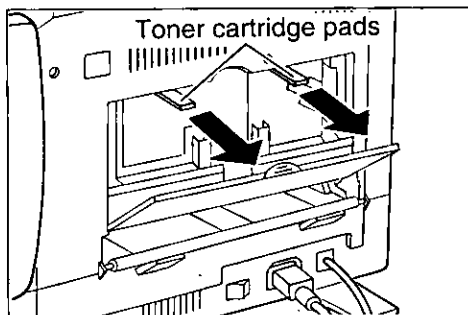

Remove the toner cartridge pads by pulling them outward.

**NOTE:**

– Place the toner cartridge pads in the storage bag and keep them in the event that the unit must be repacked and transported (see page 222).

3

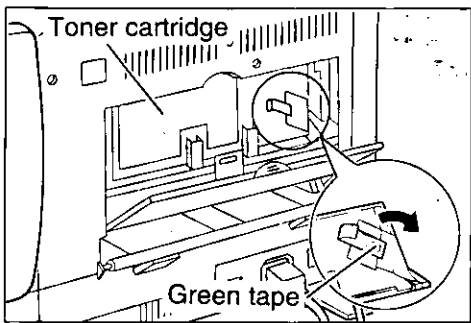

Peel off the green tape.

4

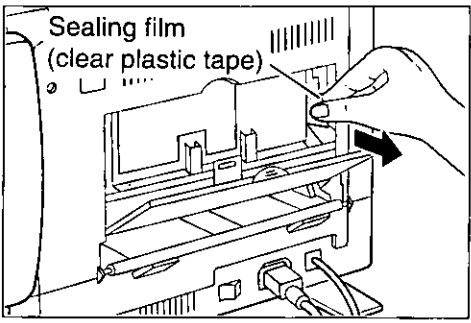

Hold the unit firmly, and completely remove the clear plastic sealing film by grasping it and pulling it outward.

**NOTES:**

- Do not twist the sealing film while pulling it, because toner may spill over.
- Be careful not to make the surrounding area dirty when handling the sealing film, because it may contain toner residue.

5

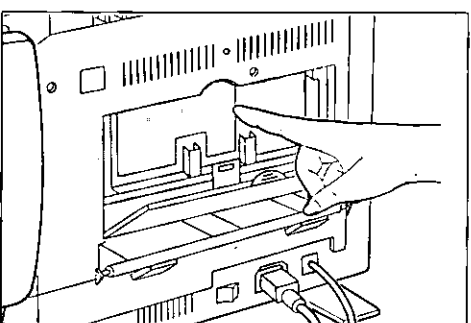

Tap the toner cartridge lightly to empty toner into the developer unit.

6

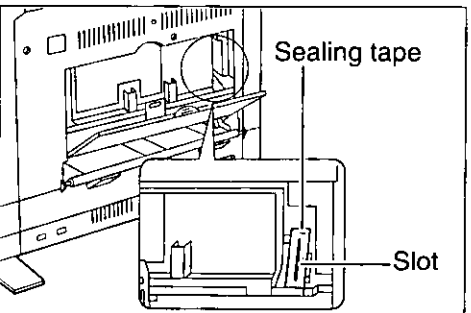

Remove the paper backing of the sealing tape provided, and press this tape over the slot on the rear side of the toner cartridge.

(continued)



7

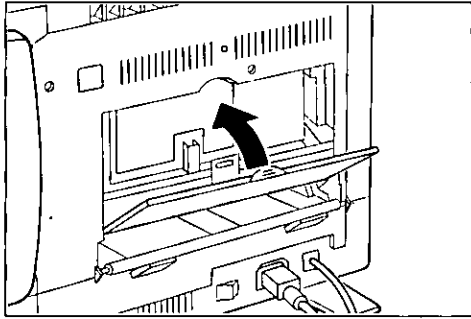

Close the cartridge compartment cover.

### ***Installing the drum unit***

**CAUTION:**

Do not open the protective bag until you have read the following instructions and are ready to install the drum unit. The drum unit contains a photosensitive drum. Exposing it to light may damage the drum.

Once you have opened the protective bag;

- Do not expose the drum unit to light for more than 5 minutes.
- Do not touch the green drum surface.
- Do not keep the drum unit near dust or dirt.
- Do not place the drum unit in a high humidity area.
- Do not expose the drum unit to direct sunlight.

1

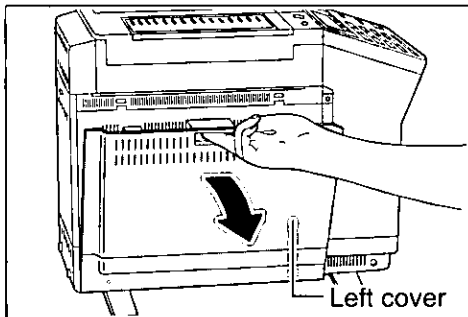

Open the left cover.

2

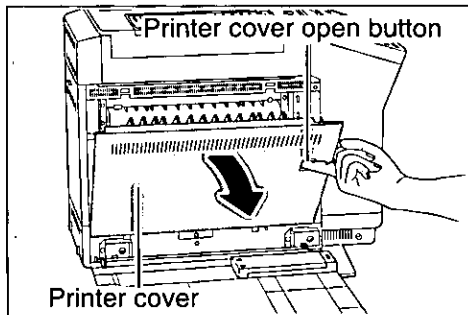

Open the printer cover by pulling the printer cover open button.



3

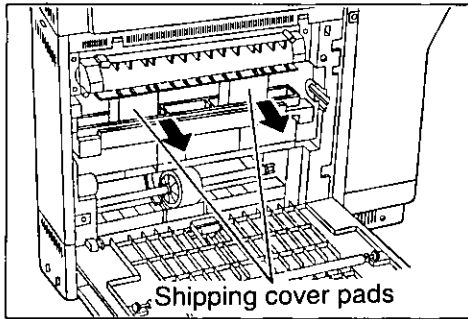

Remove the shipping cover pads by pulling them outward.

4

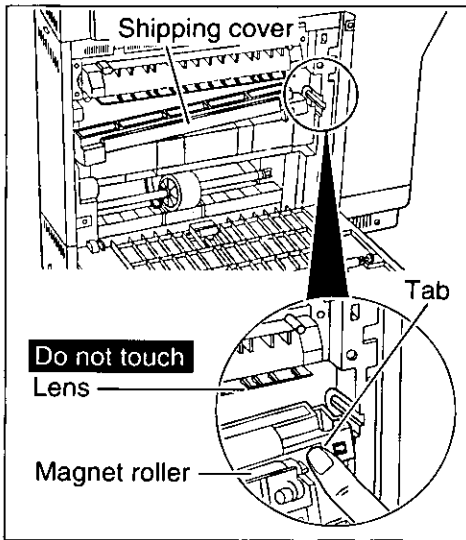

Press the tab of the shipping cover firmly toward the front, and lift the rear side of the shipping cover up and remove it by pulling it outward.

**CAUTION:**

– Do not touch the lens and magnet roller.

**NOTE:**

– Place the shipping cover in the shipping cover bag to ensure toner residue does not spill. Place this bag and the shipping pads in the storage bag and keep them in the event that the unit must be repacked and transported (see page 224).

5

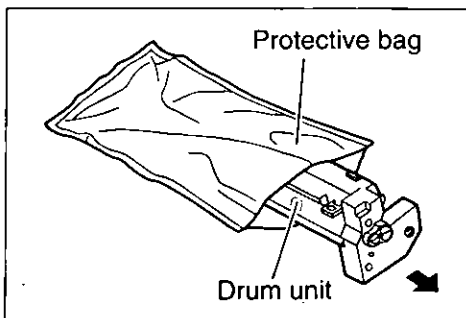

Open the protective bag by cutting the end of the bag and remove the drum unit.

**NOTES:**

– Do not expose the drum unit to light for more than 5 minutes as it may damage the drum unit.  
 – Place the protective bag in the storage bag and keep it in the event that the unit must be repacked and transported (see page 224).

6

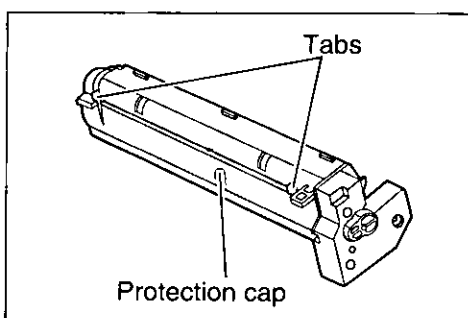

Remove the drum protection cap by pushing the right and left tabs inward.

**NOTES:**

– Do not touch the green drum surface under the protection cap as it may damage the drum unit.  
 – Place the protection cap in the storage bag and keep it in the event that the unit must be repacked and transported (see page 223).

(continued)

7

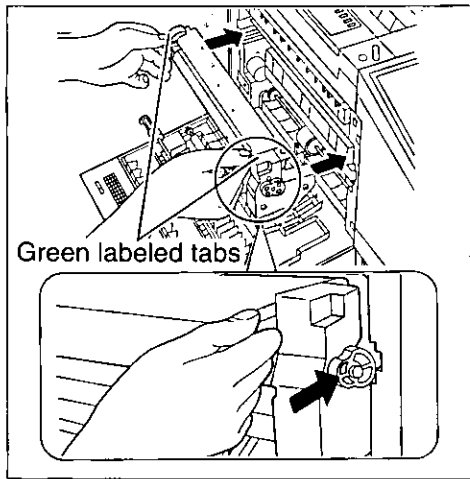

Install the drum unit by holding the green labeled tabs and pushing it firmly into place.

8

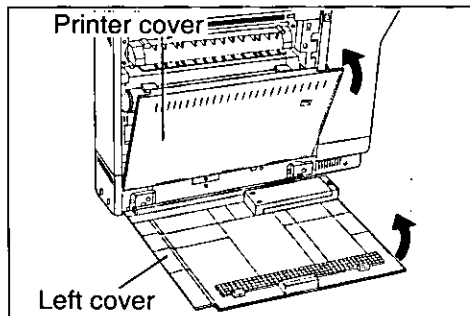

Close the printer cover and left cover.

– To close the printer cover properly, gently push on the cover where it is marked “PUSH”.

### Installing the receiving tray

1

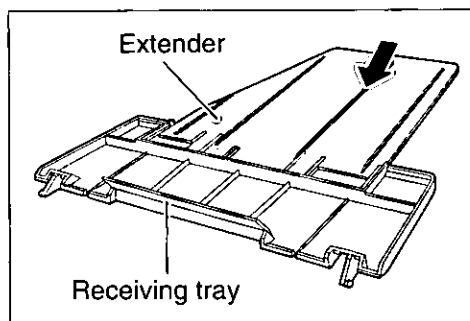

Insert the extender into the receiving tray.

2

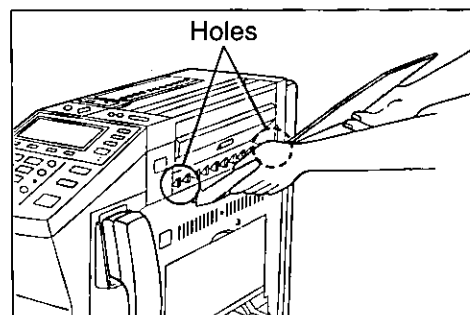

Insert the pins on the receiving tray firmly into the holes on both sides of the unit.

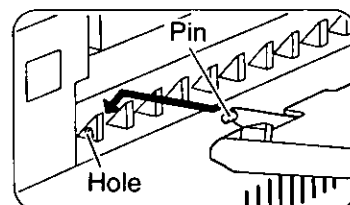

– To remove the receiving tray, see page 221.

## Installing the document feeder tray

1

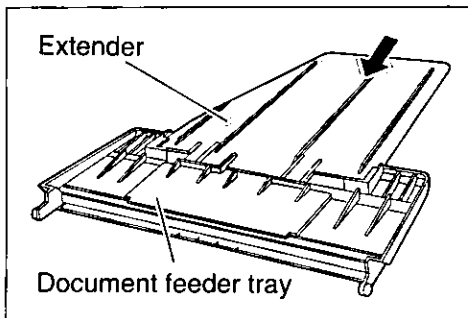

Insert the extender into the document feeder tray.

2

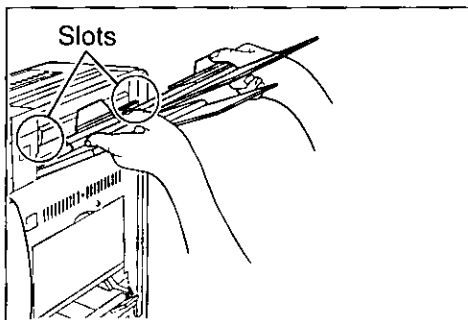

Insert the pins of the document feeder tray firmly into the slots on both sides of the unit, and the document feeder tray locks into position.

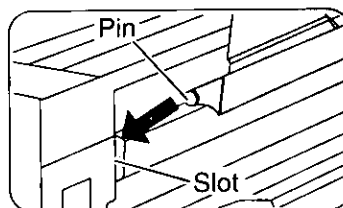

– To remove the document feeder tray, see page 221.

## Installing the paper cassette and loading paper

This unit is provided with a letter-size/legal-size cassette which can hold up to 70 sheets of 75 g/m<sup>2</sup> (20 lb.) paper. Use 60 to 90 g/m<sup>2</sup> (16 to 24 lb.) paper.

### IMPORTANT:

–The paper size is selected by pressing the LEGAL PAPER SUPPLY button after turning the power on and should match the size of the paper in the paper cassette. When the LEGAL PAPER SUPPLY indicator light is on, the legal-size is selected, and when the light is off, letter-size is selected. For further details on selecting the paper size, see page 39.

1

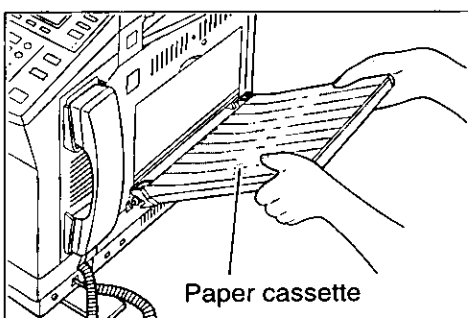

Insert the paper cassette into the unit until it clicks into place.

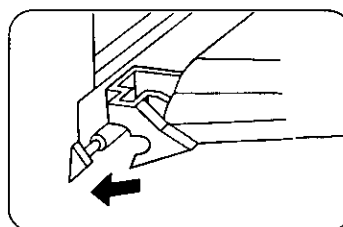

(continued)

2

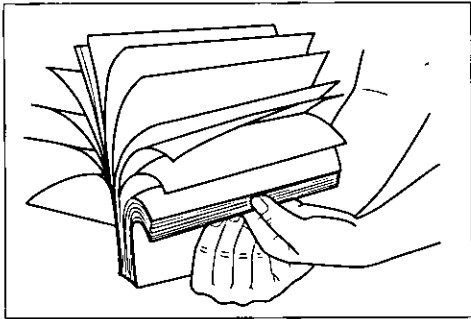

Fan the stack of paper to avoid a paper jam.

3

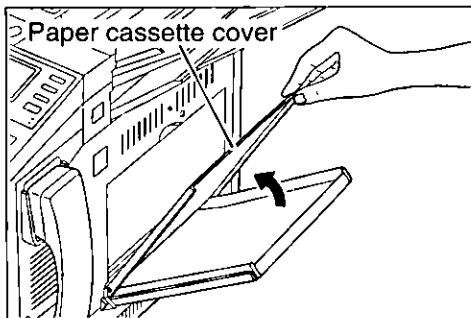

Open the paper cassette cover.

4

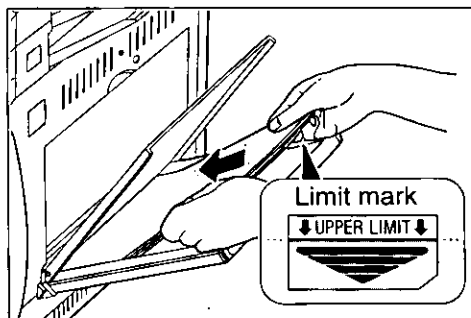

Place the paper in the paper cassette.

**NOTES:**

- The height of the paper should not exceed the limit mark on the paper cassette, because it may cause a paper jam.
- When using legal-size paper, see page 27.

5

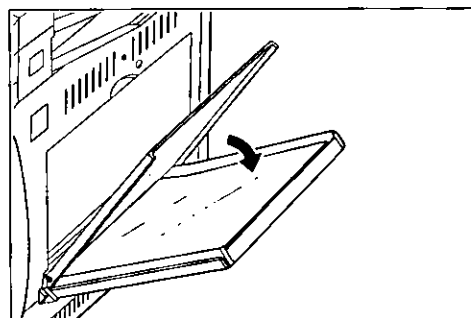

Close the paper cassette cover.

**NOTES on Paper:**

- Do not load paper of different thicknesses into the cassette at one time, because it may cause a paper jam.
- Make sure you load the paper with the print side up. Most paper has instructions recommending the side to be printed first.  
When using 60 g/m<sup>2</sup> (16 lb.) paper, always load the paper with the "non-curl side" up rather than following the instructions on the paper package.
- When adding new paper to the paper cassette, first remove the remaining paper from the cassette and then place all of the paper together into the cassette properly.

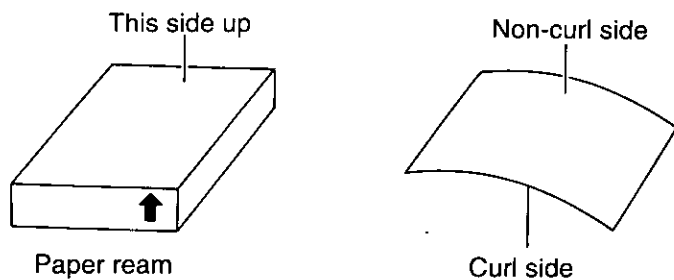

*Using legal-size paper:*

**IMPORTANT:**

- When using legal-size paper, press the LEGAL PAPER SUPPLY button after turning the power on. For further details on selecting the paper size, see page 39.

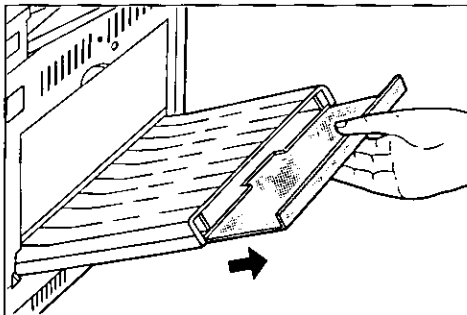

Pull out and extend the tray of the paper cassette, and then load the paper.

*Types of paper to avoid:*

- Extremely smooth or shiny paper or paper that is highly textured
- Coated paper
- Damaged or wrinkled paper
- Paper with a cotton and/or fiber content over 20%

For more detailed informations on types of paper, see page 230.

### *Printing on used paper (Double-sided printing):*

Double-sided printing is possible. However, you should not expect the same print quality and reliability that results with single-sided printing. We strongly recommend following the guidelines below.

- Use 75 to 90 g/m<sup>2</sup> (20 to 24 lb.) paper. Do not use 60 g/m<sup>2</sup> (16 lb.) paper.
- The height of the paper should not exceed the limit mark on the paper cassette.
- Before loading paper in the cassette, square it so the edges are even.

### **Installing the rechargeable battery**

The battery serves as the power source to retain greeting messages, incoming voice and fax messages recorded in memory. Use only Panasonic KX-A67 battery.

**1**

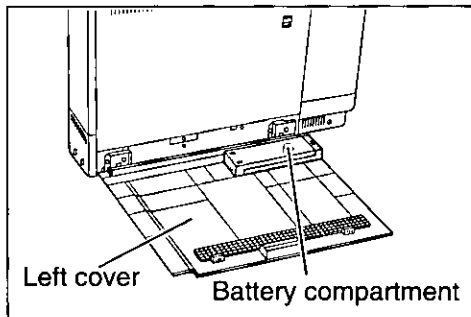

Open the left cover.

**2**

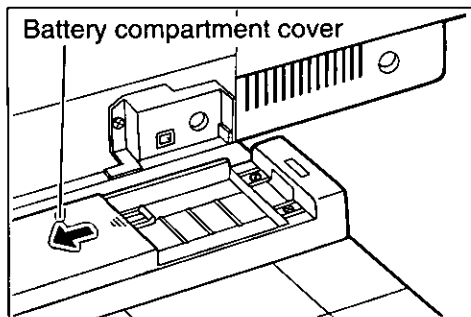

Remove the battery compartment cover by sliding and raising it slightly.

**3**

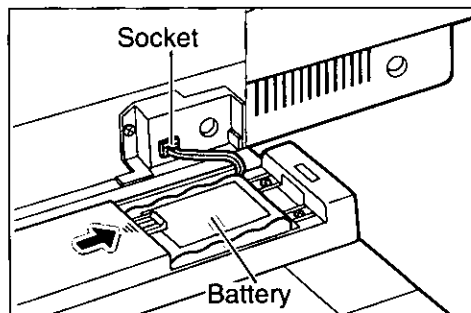

Place the battery in the battery compartment and plug the connector into the socket. Then close the compartment cover.

# 4

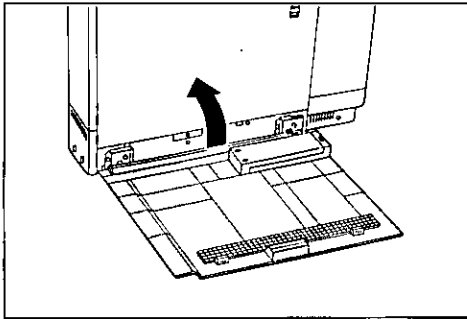

Close the left cover.

# 1

**NOTES:**

- After installing the battery and turning the power on, the display will show "CHARGING BATTERY" for about 5 hours until the battery is charged.
- As long as the unit is turned on, the battery is being charged.
- To replace the battery, see page 218.
- Disconnect the battery when the unit is turned off for a long time (longer than 2 or more days).

## Connecting the Cords

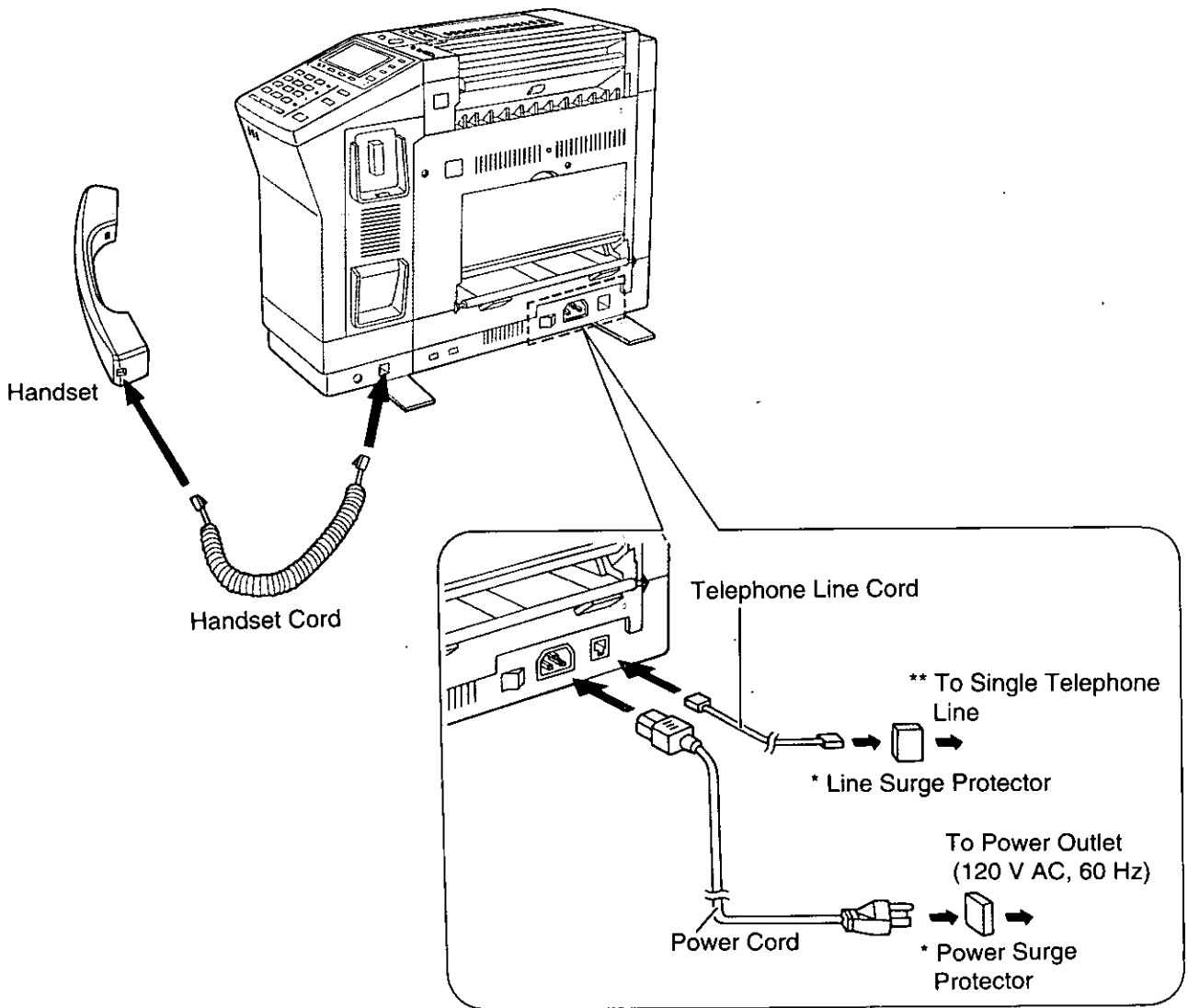

### NOTES:

- The unit will not function during a power failure or when the power is turned off.
- Connection to integrated answering machines is not recommended.
- The unit is equipped with a 3-wire grounded-type plug for safety. If you are unable to insert the plug into an outlet, contact an electrician to replace the outlet.
- We recommend the use of an exclusive power outlet to avoid interference from other equipment.

\* For additional equipment protection, we recommend the use of a surge protector. The following models will be available in United States: TELESPIKE BLOK MODEL TSB (TRIPPE MFG. CO.), SPIKE BLOK MODEL SK6-0 (TRIPPE MFG. CO.), SUPER MAX (PANAMAX), or MP1 (ITW LINX).

\*\*Type of moduler jack: RJ11C



## Turning the power switch on

Turn the power switch to the "I" (ON) position.

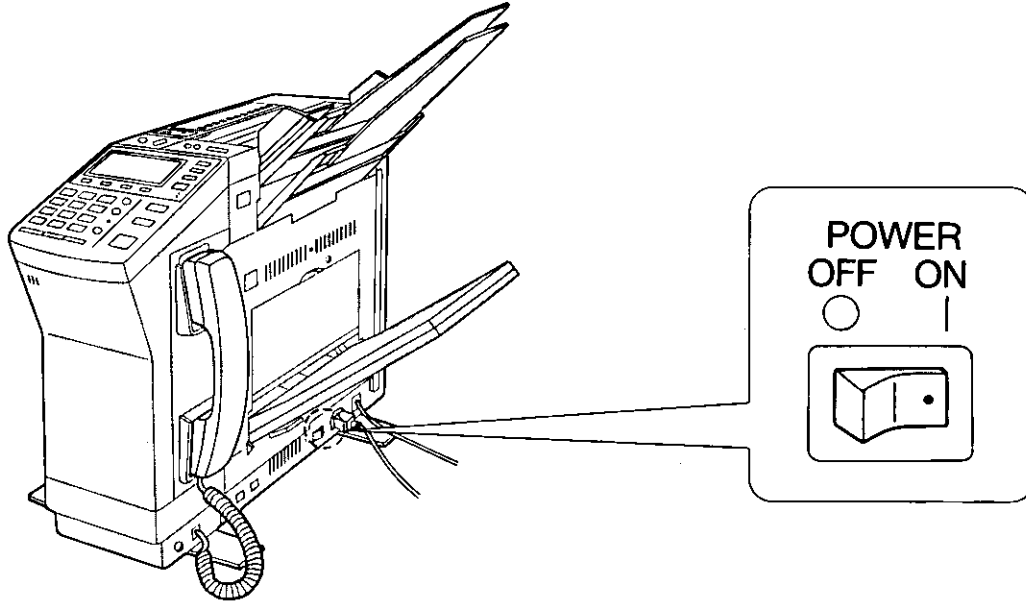

### Warming up:

When turning the unit on, the display shows the following message for a while. After warming up, your unit will be ready to use.

```
JAN29  3:00PM  -- 00
***    WARM UP  ***
```

#### NOTE:

– If the alarm indicator light is on when you turn the power switch on, confirm that the cartridge compartment cover and the printer cover are closed firmly.

### Battery charging:

After warming up, the display will show the following message for about 5 hours until the battery is charged.

```
JAN29  3:01  -- 00
* CHARGING BATTERY *
```

Even in this case, the unit will function properly. But remember that if a power failure occurs, or the unit is turned off, fax and voice messages stored in memory will be lost. The display message will disappear after the battery is charged. The battery will back up fax and voice messages stored in memory for about one day while turning off.

## Setting selectors

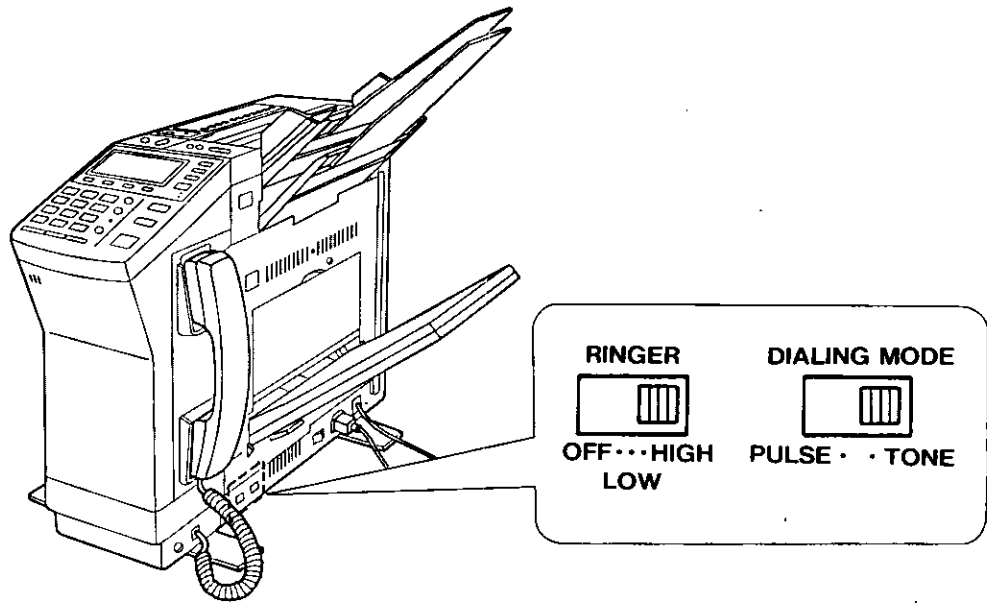

### *Dialing mode selector:*

If your telephone line has touch tone service, set the selector to **TONE**.

If your telephone line has rotary pulse dial service, set the selector to **PULSE**.

#### **HELPFUL HINT for setting the dialing mode:**

- You can ascertain what type of exchange the unit is connected to by using the following procedure:
  1. Ensure that the dialing mode selector is set to **TONE**.
  2. Lift the handset, then listen for the dial tone.
  3. Dial a familiar number.
  4. If the call is successful, the unit is connected to a tone exchange. Leave the selector set to **TONE**.
  5. If the call is not successful, the unit is connected to a pulse exchange. Switch the selector to **PULSE**.

### *Ringer volume selector:*

**HIGH:** The ringing sound of your unit will be loud.

**LOW:** The ringing sound of your unit will be soft.

**OFF:** The unit will not ring.

# Display Indication

The unit has a liquid crystal display, which is used to view and confirm the programming state and others.

– The following display shows the possible configurations.

**Memory Counter:**

Shows the amount of memory used (up to 99%) when using memory.

**Call Counter:**

Counts the number of newly recorded incoming voice-messages up to 99 (page 69).

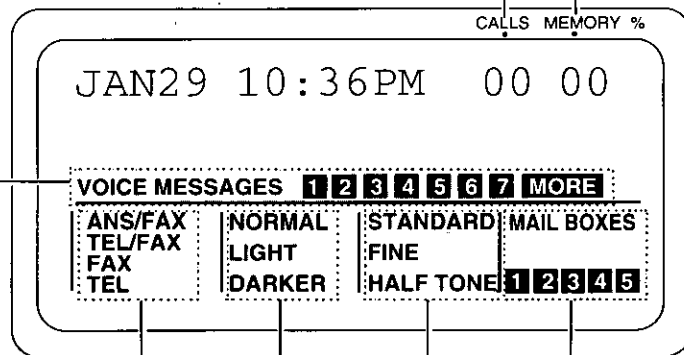

**Voice-message Indicator:**

Shows the number of recorded incoming voice-messages up to 7. When more than 8 messages are recorded, "MORE" is displayed. The flashing number shows which message has not been listened to (page 69).

**Mail Box Indicator:**

Shows which mail box number the documents have been received in (page 118).

**Resolution Indicator:**

Shows the definition being set (page 53).

**Original Indicator:**

Shows the document contrast being set (page 53).

**Receiving Mode Indicator:**

Shows the receiving mode being set (page 37).



# Recording Your Greeting Messages

---

Record two types of greeting messages before using your unit as an answering machine and facsimile. One is the message for the *ANS/FAX* mode, and the other is for the *TEL/FAX* mode.

The greeting message for the *ANS/FAX* mode tells a caller that you are unable to answer, and allows the caller to leave a voice-message or to send a fax-message.

The greeting message for the *TEL/FAX* mode tells a caller that the unit is calling you up, and allows the caller to wait until you answer the call or to send a fax message.

You can record each greeting message up to 16 seconds.

## Suggested messages

Record your greeting messages referring to the examples below:

### ■ Greeting message for the *ANS/FAX* mode:

*"This is (your name, business and/or telephone number). We are unable to answer right now. To send a fax, start transmission. To leave a message, speak (or 'speak for up to 1 minute') after the long beep. Thank you."*

You can choose from two lengths of recording times for incoming messages. One is unlimited (pre-selected setting), and the other is limited to 1 minute. The example above corresponds to these two conditions. To change the recording time, see page 165.

### ■ Greeting message for the *TEL/FAX* mode:

*"This is (your name, business and/or telephone number). Wait for a while, please. To send a fax, start transmission."*

## How to record your greeting messages

Recording time is limited to 16 seconds per each message. Record your greeting message within 12 seconds for optimum performance. Proceed the following steps each message and record your message.

1

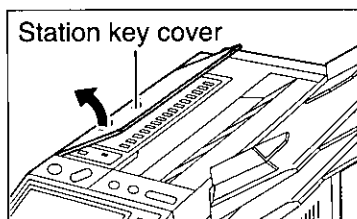

Open the station key cover.

2

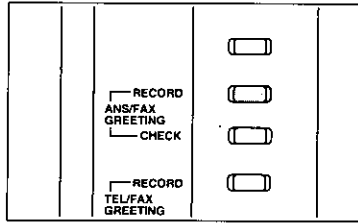

or

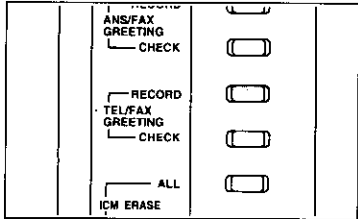

■ Recording the greeting message for the **ANS/FAX mode:**

Press **ANS/FAX GREETING RECORD**.

GREETING RECORDING  
ANS/FAX >>>>>>>>

or

■ Recording the greeting message for the **TEL/FAX mode:**

Press **TEL/FAX GREETING RECORD**.

GREETING RECORDING  
TEL/FAX >>>>>>>>

A beep is heard, and then the unit starts recording.

3

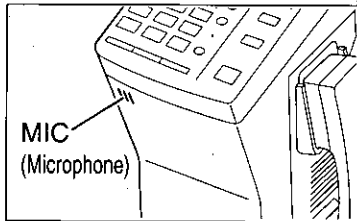

After the beep, speak immediately, clearly and loudly toward the microphone from a distance of approximately 200 mm (8 inches).

4

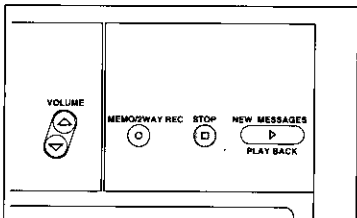

When finished, press **STOP**.

GREETING CHECKING  
ANS/FAX >>>>>>>>

or

GREETING CHECKING  
TEL/FAX >>>>>>>>

- When 16 seconds have passed from the beginning, the unit finishes recording your greeting message automatically.
- After a beep, the unit plays back your message so that you can confirm it.
- Adjust the speaker's volume to a suitable level by pressing the VOLUME control ( $\Delta$  or  $\nabla$ ) button.

**NOTES:**

- If you make a mistake while recording, repeat from step 2.
- If you want to change your message, repeat the operation on pages 34 and 35. The previous message will be automatically erased and the new message will be recorded.

1

## How to check your greeting messages

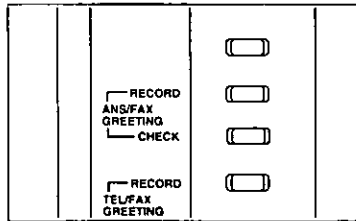

- **Checking the greeting message for the *ANS/FAX* mode:**  
Press **ANS/FAX GREETING CHECK**.

GREETING CHECKING  
ANS/FAX >>>>>>>>

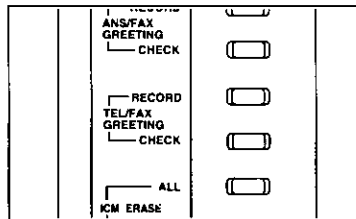

- **Checking the greeting message for the *TEL/FAX* mode:**  
Press **TEL/FAX GREETING CHECK**.

GREETING CHECKING  
TEL/FAX >>>>>>>>

After a beep, the unit replays your greeting message.

# Selecting the Receiving Mode

Depending on your situation, select the desired receiving mode.

**ANS/FAX mode**—When you wish to use the unit as a telephone answering device and a facsimile, or when the unit is unattended.

**TEL/FAX mode** —When you wish to use the unit as a standard telephone and a facsimile machine without answering facility.

**FAX mode** —When you wish to use the unit as a facsimile machine only.

**TEL mode** —When you wish to use the unit as a standard telephone.

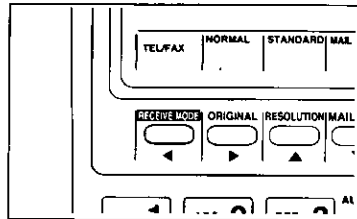

Press **RECEIVE MODE** to select the desired receiving mode.

The display shows the selected receiving mode.

When a fax or voice call comes in, the unit will function as follows:

## **ANS/FAX mode**

- When a voice call comes in, the unit will ring and play your greeting message recorded to the calling party, and the unit will be ready to record a voice message of the other party.
- If the calling party does not wish to record any voice message, advise them to press the asterisk key twice ( \* \* ) using tone dialing while playing the greeting message or incoming message recording mode. The answering device feature will be interrupted and the unit will activate fax function. The calling party will be able to send a document.
- If the calling party wishes to send a document after hearing your greeting message, advise them to leave the unit with mute for 5 more seconds. The unit will activate fax function, and the calling party will be able to send a document.
- When an automatic fax transmission call comes in, the unit will ring and activate the fax function without playing your greeting message.

## **NOTES:**

- You should record your greeting message first into your unit before using this mode. See pages 34 and 35.
- You can program the recording time for a voice of the other party. See page 165.
- When a call comes in, the unit will ring depending on the setting of the ANS/FAX ring count. You can also set the ringer to off. To change the setting, see page 163.
- If you answer the call during playing the greeting message or recording an incoming voice message, you will be able to talk to the other party.
- When you answer a call and the pip tones sound or nothing is heard, the call may be a fax call. Press the START button to receive a document.

### **TEL/FAX mode**

- When a voice call comes in, the unit will seize the call immediately, and the unit will play your greeting message recorded to the calling party and emit the simulated ring tones to the calling party.  
If you answer the call during ringing, you will be able to talk to the other party.  
If someone does not answer the call, the unit will automatically activate the fax function. The calling party will be able to transmit a document.
- When a fax call comes in, the unit will automatically activate the fax function without ringing.

#### **NOTES:**

- A telephone fee will be charged to the calling party once the greeting message is heard, because the line is already connected from that time.
- If you are connecting a reserve telephone on the same line, the reserve telephone will ring depending on the setting of the program (see page 182) before the unit rings or initiates fax reception. For further details on the reserve telephone, see page 155.

### **FAX mode**

- When a fax call comes in, the unit will ring and activate the fax function.
- When a voice call comes in, the unit will ring and emit a fax tone to the calling party. The calling party will be able to transmit a document. You cannot talk to the other party.

#### **NOTE:**

- Inform your callers that your unit is used for a facsimile machine only.

### **TEL mode**

- When a call comes in, you will have to answer every call.
- When you answer a call and a slow beep is heard or nothing is heard, the call may be a fax call. Press the START button to receive a document.

#### **NOTE:**

- If someone calls your unit until the unit rings 15 times, the receiving mode of the unit will be changed to the *ANS/FAX* mode from the *TEL* mode automatically.

#### **HELPFUL HINTS:**

- Making calls and transmitting documents are possible in every receiving mode.
- For the operations of receiving documents in each receiving mode, see pages 58 to 61.
- If you select the *ANS/FAX* or *TEL/FAX* mode when no greeting message for each receiving mode is recorded, the following is shown:

```
JAN 1 12:00AM 00 00  
RECORD ANS-GREETING
```

Record the greeting message for the *ANS/FAX* mode. See page 34.

```
JAN 1 12:00AM 00 00  
RECORD TEL-GREETING
```

Record the greeting message for the *TEL/FAX* mode. See page 34.



# Selecting the Paper Size

The paper size is selected by pressing the LEGAL PAPER SUPPLY button and should match the size of the paper in the paper cassette.

Pressing the LEGAL PAPER SUPPLY button alternates between letter-size and legal-size paper. The LEGAL PAPER SUPPLY indicator and the display show the paper size selected.

## ■ LEGAL PAPER SUPPLY indicator:

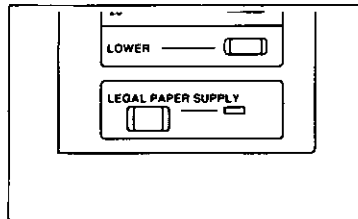

Light off ... Letter-size is selected.

Light on ... Legal-size is selected.

## ■ Display:

```
PAPER SUPPLY
=LETTER SIZE
```

or

```
PAPER SUPPLY
=LEGAL SIZE
```

The display shows the selected paper size for 5 seconds after pressing the LEGAL PAPER SUPPLY button.

## CAUTION:

– If the unit has been set to print on legal-size paper but letter-size paper is installed, the unit will not print and the display will show the following message:

```
CHECK PAPER SIZE
PRESS MENU KEY
```

(While receiving)

or

```
CHECK PAPER SIZE
PRESS STOP/CLEAR
```

(While copying)

See page 192 to continue printing. If you press the LEGAL PAPER SUPPLY button to change the paper size setting while the above message is displayed, the first page received will not be printed.

# System Programming Features

The unit has the following features, and they are divided into the basic and advanced features.

Basic features are the settings that need to be programmed upon completing the installation. Most of the probable choices have already been pre-selected, but some features such as the current date and time, the company name or personal name, and your facsimile telephone number, must be programmed by the user.

Advanced features should be programmed as the need arises.

**Before using your unit as a facsimile, always set the following features:**

- #01 The current date and time (page 43)
- #02 Your company name or personal name (page 44)
- #03 Your facsimile telephone number (page 44)

**HELPFUL HINT:**

- If you lose your instructions while programming the basic features, press the HELP button. The unit will print information on how to program (see page 10).

## Basic features

The underlined selections indicate the pre-selected settings.

Program No.	Functions	Indications	Selections	Pages
#01	The current date and time	SET DATE	_____	43
#02	Your company name or personal name	YOUR LOGO	up to 30 characters	44
#03	Your facsimile telephone number	YOUR TELEPHONE NUMBER	up to 20 digits	44
#04	Individual transmission report	PRINT TRANSMISSION REPORT	<u>Error</u> / On / Off	160
#05	Memory transmission	MEMORY XMT	On / <u>Off</u>	115
#06	Number of rings to answer in the FAX mode	FAX RING COUNT	1 to 4 rings <u>(1 ring)</u>	162
#07	Number of rings to answer in the ANS/FAX mode	ANS/FAX RING COUNT	1 to 4 rings or Toll saver or No ring <u>(1 ring)</u>	163
#08	Remote operation code for the answering device	REMOTE ANS ID	3 digits <u>(111)</u>	139
#09	Recording time for incoming message	RECORDING TIME FOR ANS	<u>unlimited</u> or 1 minute	165

## Advanced features

The underlined selections indicate the pre-selected settings.

Program No.	Functions	Indications	Selections	Pages
#10	Logo print position on the transmitted document	LOGO POSITION	<u>Out</u> / In	166
#11	Auto/Manual journal report printing	JOURNAL AUTO PRINT	<u>Auto</u> / Manual	167
#12	Passcode for network communication	NETWORK PASSCODE	4 digits <u>(0000)</u>	123
#13	Transmission passcode check mode for network communication	TX PASSCODE CHECK	On / <u>Off</u>	126
#14	Reception passcode check mode for network communication	RX PASSCODE CHECK	On / <u>Off</u>	127
#15	Passcode for polling function	POLLING PASSCODE	4 digits <u>(0000)</u>	110
#16	Number of the silent fax recognition ring	SILENT FAX RECOGNITION RING	3 to 8 rings <u>(3 rings)</u>	170
#17	Remote fax activation code	REMOTE FAX ACTIVATION CODE	2 to 4 digits <u>(**)</u>	157
#18	Personal message for the customized header	ENTER MESSAGE D	up to 64 characters	136
#19	Copy mode	COPY MODE	<u>Reduction (REDT)</u> or Inhibition (INH) or Extension (EXTND)	171, 173
#20	Reduction mode for receiving fax	RX REDUCTION	92% Reduction (RED 1) or <u>72% Reduction (RED 2)</u> or Inhibition (INH)	175, 176

(continued)

## Advanced features (cont.)

The underlined selections indicate the pre-selected settings.

Program No.	Functions	Indications	Selections	Pages
#21	Fax forwarding mode and forwarding facsimile telephone number	FAX FORWARDING	On / <u>Off</u>	128
#23	Distinctive ring pattern of the fax call for the automatic reception	RING PATTERN DETECTION	A: Standard ring or B: Double ring or C: Triple ring or D: Other triple ring or <u>Off</u>	177
#24	Brightness of the display	LCD CONTRAST	Light (LIGH) or <u>Normal (NORM)</u> or Dark (DARK)	179
#25	Privacy ring ID number	PRIVACY RING ID	3 digits (333)	149
#26	Day/Night mode and start time	DAY/NIGHT MODE	On / <u>Off</u>	180
#27	Number of rings of the reserve phone to answer in the TEL/FAX mode	TEL/FAX DELAYED RING	1 to 4 rings ( <u>1 ring</u> )	182
#28	Maximum transmission speed	TX SPEED	<u>A: 9600 bps</u> B: 7200 bps C: 4800 bps D: 2400 bps	184
#29	Message alert setting	MESSAGE ALERT	<u>On</u> / Off	185
#50	Reset of the basic and advanced features to the initial settings (Except for the basic features #01 to #03)	SET DEFAULT	Yes / <u>No</u>	186

## Setting date and time

The internal clock of the unit will print the date and time on the top line of all fax communication messages you transmit and fax reports, such as the journal report and the transmission report.

### HELPFUL HINT:

- If you lose your instructions while setting, press the HELP button. The unit will print information on how to set.

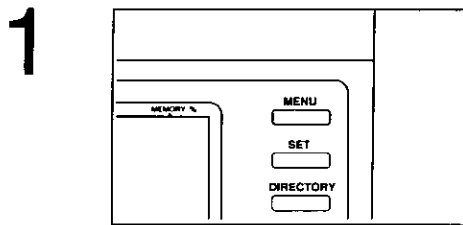

Press **MENU** until the following is shown.

```

PROG. [1.DATE 2.TEL
3.SYSTEM 4.REPORT]
    
```

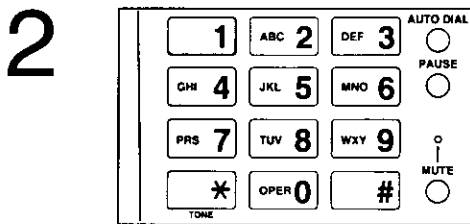

Press **1** to start programming.

```

SET DATE[.=AM #=PM]
01 29 94 10:36PM SAT
    
```

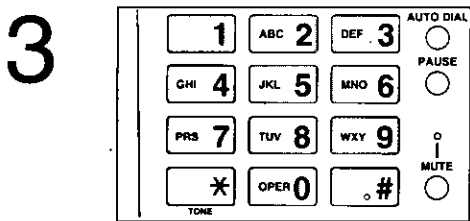

Enter the current month/day/year/hour/minute by selecting 2 digits each.

- Example:** Aug. 10 1994, 3:00PM.  
 Press **08, 10, 94, 03**, then press **00**.  
 Press **#** to select PM mode.

```

SET DATE[.=AM #=PM]
08 10 94 03:00PM WED
    
```

- It is not necessary to enter a day of the week.
- To select AM mode, press \*.
- If you make a mistake, use the cursor key (◀ or ▶) to move the cursor to the incorrect number, then make the correction.

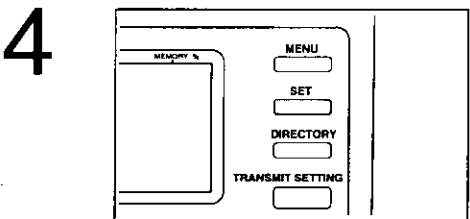

Press **SET** to store the program into memory.

```

PROG. {1.DATE 2.TEL
3.SYSTEM 4.REPORT}
    
```

(continued)

# 5

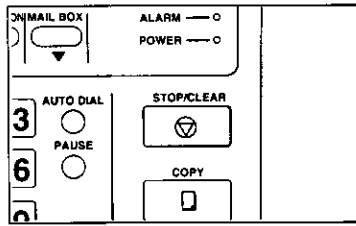

Press **STOP/CLEAR** to end the programming.

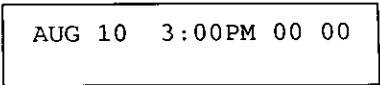

### NOTES:

- To cancel programming halfway, press the MENU button.
- The accuracy of the internal clock will be approximately  $\pm 60$  seconds a month in the operating environment.

## Setting your logo and facsimile telephone number

**Your logo:** The logo is used to identify fax messages that are being transmitted by your unit. It may consist of alpha-numeric letters and symbols. Usually the logo is a company, division, or personal name in an abbreviated form. The printed logo can be up to 30 characters in length.

**Your facsimile telephone number:** Your facsimile telephone number can be programmed into your unit. The unit can store the number up to 20 digits in length.

Your programmed logo and telephone number will be printed on the top of each page transmitted from your unit, along with the date, time, and page number.

This will give the receiving party your name and fax telephone number if they wish to return a fax.

### Sample page sent by your unit:

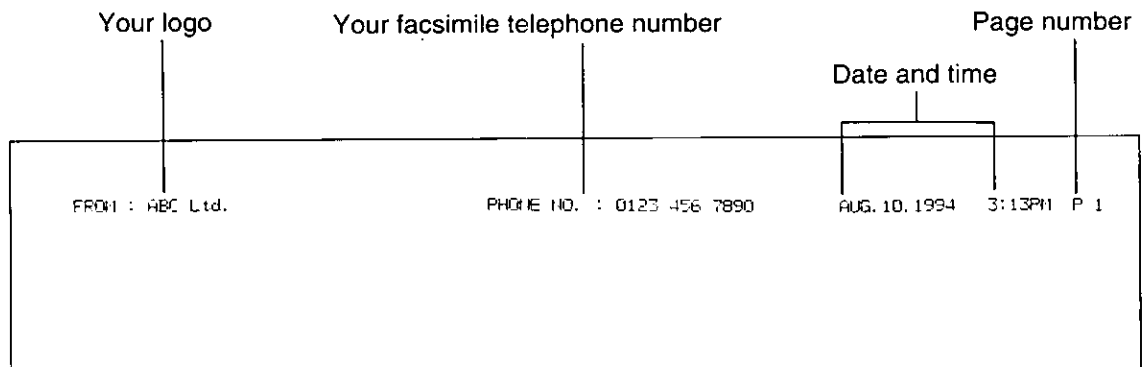

To set your logo and facsimile telephone number, proceed as follows:

**HELPFUL HINT:**

- If you lose your instructions while setting, press the HELP button. The unit will print information on how to set.

**1**

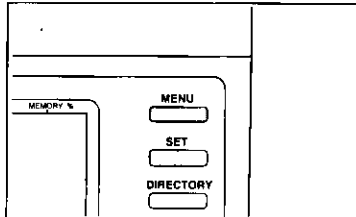

Press **MENU** until the following is shown.

PROG. [1.DATE 2.TEL  
3.SYSTEM 4.REPORT]

**2**

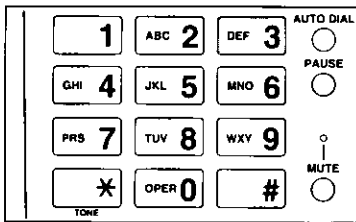

Press **3** to start programming.

ENTER YOUR LOGO  
=Panasonic PPF

- The unit is pre-programmed to "Panasonic PPF" as your logo.

**3**

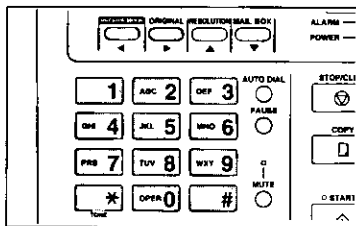

Enter your logo up to 30 characters by using the character keys and the cursor key (◀ or ▶).

- For further details on using the character keys, the command keys, and the cursor key (◀ or ▶), see pages 47 to 49.
- When the first character is entered, the pre-programmed logo is cleared.

**Example:** The logo is "ABC Ltd".

1. Press 2 once to select "A" then ▶.
2. Press 2 twice to select "B" then ▶.
3. Press 2 three times to select "C" then ▶.
4. Press the station number 9 of the direct call station key to select "space" then ▶.
5. Press 5 three times to select "L" then ▶.
6. Press 8 four times to select "t" then ▶.
7. Press 3 four times to select "d" then ▶.
8. Press the station number 3 four times to select "." (period).

ENTER YOUR LOGO  
=ABC Ltd.

- If you make a mistake, use the cursor key (◀ or ▶) to move the cursor to the incorrect character, then make the correction.

(continued)



4

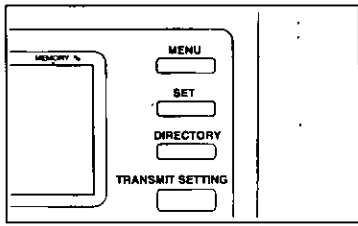

Press **SET** to store the program into memory.

```

ENTER YOUR TEL #
=
  
```

5

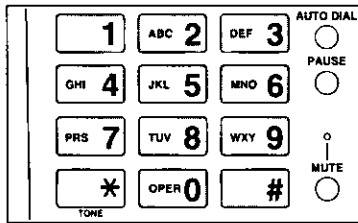

Enter your facsimile telephone number up to 20 digits by using the dial keypad.

**Example:** If the phone number is 0123 456 7890, press **0123**, #, **456**, #, then press **7890**.

```

ENTER YOUR TEL #
=0123 456 7890
  
```

- Pressing the # button provides one space and pressing the \* button provides the mark "+".
- If you make a mistake, use the cursor key ( ◀ or ▶ ) to move the cursor to the incorrect number, then make the correction.

6

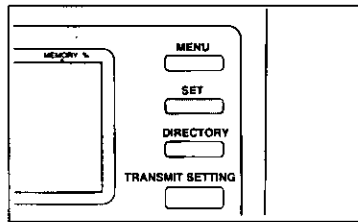

Press **SET** to store the program into memory.

```

XMT REPORT =ERROR
[1.ERROR 2.ON 3.OFF]
  
```

7

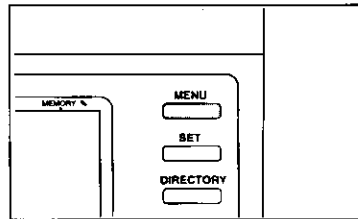

Press **MENU** to end the programming.

**NOTE:**

- To cancel programming halfway, press the MENU button.



## How to use the character keys

The dial keypad and the direct call station keys are also used as alphabet and symbol character input keys when programming your logo, the direct call station names, and the speed dial station names.

### Direct Call Station Keys:

The character layout of the direct call station keys is printed on the reverse side of the directory card.

Remove the directory card cover with a pen, pin or similar object, as shown.  
Turn the directory card over.

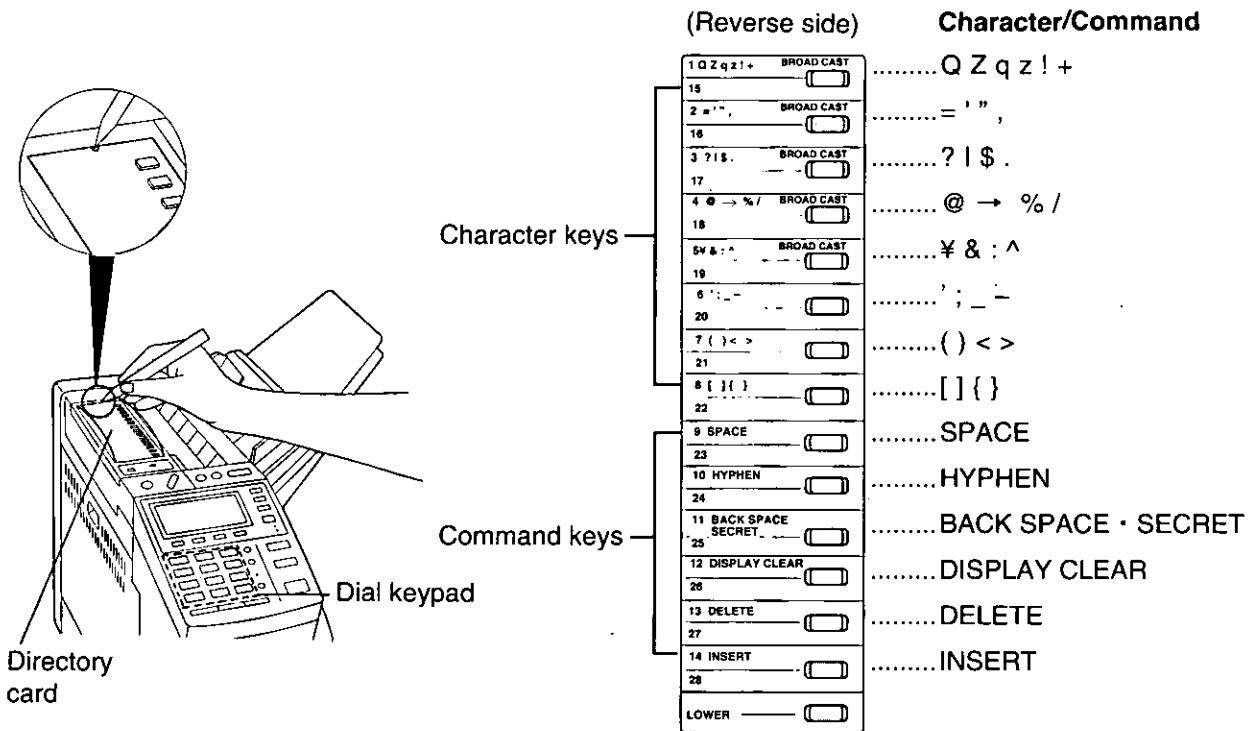

### Dial Keypad:

Keypad: Character:

1 ... 1

GHI 4 ... G H I g h i 4

PRS 7 ... P Q R S p q r s 7

\* ... \*  
TONE

Keypad: Character:

ABC 2 ... A B C a b c 2

JKL 5 ... J K L j k l 5

TUV 8 ... T U V t u v 8

OPER 0 ... 0

Keypad: Character:

DEF 3 ... D E F d e f 3

MNO 6 ... M N O m n o 6

WXY 9 ... W X Y Z w x y z 9

# ... #

*To enter numbers, symbols, and characters:*

Close the station key cover, and enter the characters using the following keys.

■ **Cursor keys**

◀ **key (RECEIVE MODE button):**  
The cursor is moved one space to the left each time you press this key.

▶ **key (ORIGINAL button):**  
The cursor is moved one space to the right each time you press this key.

■ **Character keys and dial keypad**

The character on the display is changed each time you press one of these keys.

For example, when you press **2** repeatedly, the display shows:  
A → B → C → a → b → c → 2 → A

To enter a character and move to the next character, press ▶ (ORIGINAL button) once.

■ **Command keys**

**SPACE key:**  
This key is used to replace one character to the space.

**HYPHEN key:**  
This key is used to enter a hyphen.

**BACK SPACE key:**  
This key is used to delete one character to the left side of the cursor while it moves backward.

e.g., Panasonic → Panaso ic

1. Press ◀ repeatedly until the cursor is positioned on "n".

```
ENTER YOUR LOGO
=Panasonic
```

2. Press **BACK SPACE**.

```
ENTER YOUR LOGO
=Panaso ic
```

**SECRET key:**  
To keep a phone number secret while storing it into memory for automatic dialer, press the SECRET key at the beginning and end of the phone number.  
For further details, see page 87.

**DISPLAY CLEAR key:**  
This key is used to erase all the characters entered.

**DELETE key:**  
This key is used to delete one character.

e.g., Panasonic → Panaso ic

1. Press ◀ repeatedly until the cursor is positioned on "s".

```
ENTER YOUR LOGO
=Panasosnic
```

2. Press **DELETE**.

```
ENTER YOUR LOGO
=Panaso nic
```

**INSERT key:**  
This key is used to insert one character or one space.

e.g., Panaonic → Panaso nic

1. Press ◀ repeatedly until the cursor is positioned on "o".

```
ENTER YOUR LOGO
=Panaonic
```

2. Press **INSERT**, then press **7** repeatedly until "s" is shown.

```
ENTER YOUR LOGO
=Panasosnic
```

To enter all characters in capitals:

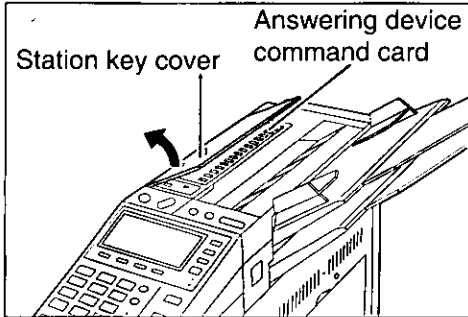

Open the station key cover and remove the answering device command card, then turn it over.

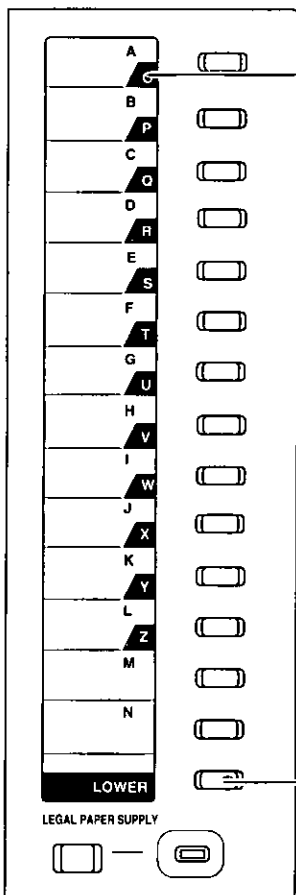

The highlighted character in each lower position can be entered by pressing the corresponding key after pressing the LOWER key.

For example, when you want to enter "PANASONIC":

- 1 Press **LOWER** then "P".
- 2 Press "A".
- 3 Press "N".
- 4 Press "A".
- 5 Press **LOWER** then "S".
- 6 Press **LOWER** then "O".
- 7 Press "N".
- 8 Press "I".
- 9 Press "C".

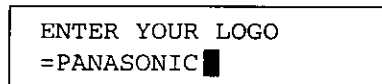

LOWER key

(Reverse side of the answering device command card)

**NOTE:**

- If you make a mistake, use the cursor key ( ◀ or ▶ ) to move the cursor to the incorrect character, then make the correction. The character on the cursor position will be replaced with the new entry.



# **Chapter 2**

## *Basic Instructions*

# Transmitting Documents

---

## Before transmitting documents

### Acceptable documents:

The unit can transmit documents that meet the following conditions:

- Document width should be from 128 to 216 mm (5" to 8 $\frac{1}{2}$ ").
- Maximum document length should not exceed 660 mm (26").
- Effective scanning width can be up to 208 mm (8 $\frac{3}{16}$ ").
- Number of pages that can be set in the document feeder tray must not exceed 20 pages.
- Document weight:
  - Single sheet: 45 to 90 g/m<sup>2</sup> (12 to 24 lb.)
  - Multiple sheets: 60 to 75 g/m<sup>2</sup> (16 to 20 lb.)

Minimum document size

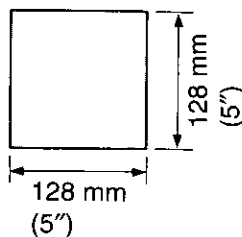

Maximum document size

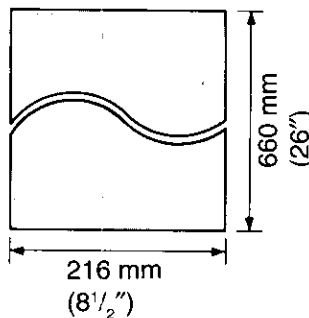

Effective scanning width

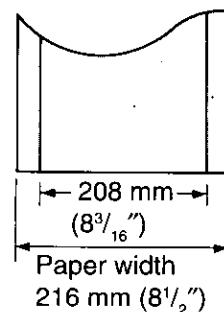

### Unacceptable documents:

The following documents may cause a jam:

- Documents bound with clips, staples, or other similar objects
- Documents on which ink, paste, or correction fluid has not completely dried

Do not use the following types of documents. Make a clear copy of these documents and then feed the copy into the unit.

- Paper with a chemically treated surface, such as carbon paper or carbonless duplicating paper
- Electrostatically charged paper
- Heavily curled, creased, or torn paper
- Paper with a coated surface
- Small-sized paper such as a slip or voucher
- Thin paper less than 45 g/m<sup>2</sup> (12 lb.)
- Thick paper over 90 g/m<sup>2</sup> (24 lb.)
- Paper with faint contrast between the print and the background
- Paper with printing on the reverse side that can be seen through the front (e.g. newspaper)

## Contrast and resolution:

You can set the contrast and resolution modes, depending on the quality of the original. Set these modes before transmission or copying. If they are set during transmission or copying, they will be effective from the next page scanned.

The display shows the current settings of the contrast and resolution modes.

### Contrast:

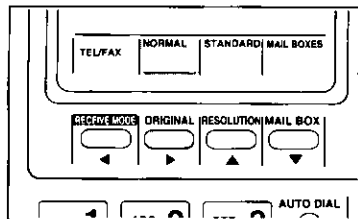

Press **ORIGINAL** to change the contrast mode.

**NORMAL** is suitable for originals with normal writing.

**LIGHT** is suitable for originals with faint writing.

**DARKER** is suitable for originals with dark writing.

- The contrast mode automatically returns to the normal mode after transmission or copying.
- When you set the LIGHT or DARKER mode, it may take longer time to transmit documents.

### Resolution:

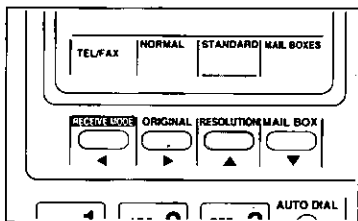

Press **RESOLUTION** to change the resolution mode.

**STANDARD** is suitable for printed or typewritten originals with normal-sized characters.

**FINE** is suitable for originals with small printed characters or detailed drawings.

**HALF TONE** is suitable for originals containing photographs, shaded drawings, etc.

- The resolution mode automatically returns to the standard mode after transmission or copying.
- When you set the FINE or HALF TONE mode, it takes longer time to transmit documents.



### Loading documents:

1

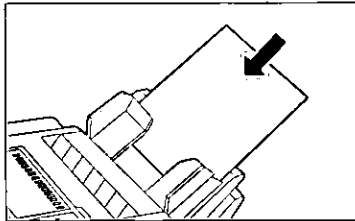

Insert the documents **FACE DOWN** into the document feeder tray.

A beep is heard.

– The unit can accept up to 20 pages at a time.

2

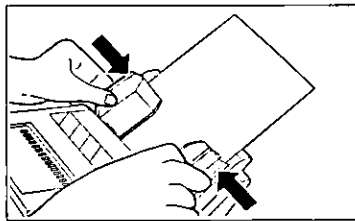

Adjust the document guides to the width of the documents.

3

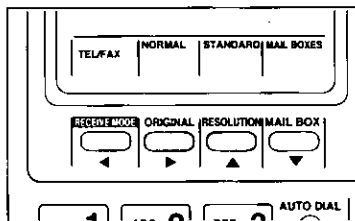

Set the contrast or resolution mode by using **ORIGINAL** or **RESOLUTION** if needed.

4

Start the transmitting operation.

### HELPFUL HINTS:

You can transmit documents manually and automatically.

- To make a manual transmission, see pages 55 to 57.
- To make an automatic transmission, store phone numbers into memory first (see pages 81 to 88) and then start transmission (see pages 97 to 101).
- To make a copy, see page 66.

### Adding extra pages:

If you want to send 21 or more pages at a time, insert the first 20 pages of the document and add the extra pages, up to 20 pages at a time, before the last page is fed into the unit.



## Manual transmission (Case 1)

1

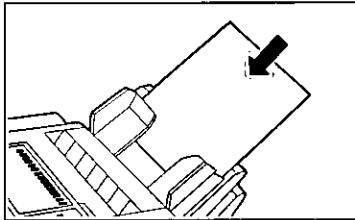

Insert the documents FACE DOWN.

A beep is heard.

– The unit can accept up to 20 pages at a time.

2

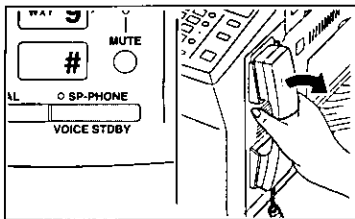

Press **SP-PHONE** or lift the handset, and listen for the dial tone.

```
AUG10  3:00PM 00 00
ENTER PHONE NUMBER
```

– If pressing **SP-PHONE**, the SP-PHONE indicator light will be on.

3

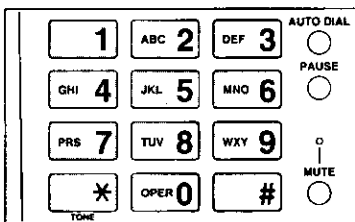

Dial the phone number of the receiving party.

**Example:** 1234567 is dialed.

```
AUG10  3:00PM 00 00
1234567
```

– If the other party answers, ask them to press their start or transmit button to start the fax reception.

– If you misdialed, press **FLASH** firmly. The dial tone will sound, and dial the correct number.

4

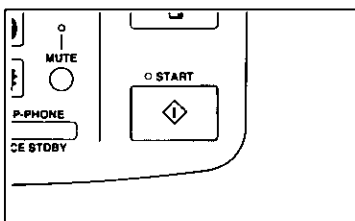

Press **START** when a fax tone is heard.

The START indicator light is flashing.

```
SENDING          P 1
TO:1234567
```

5

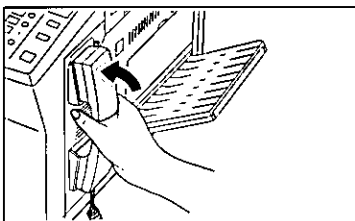

Place the handset on the cradle if using it.

The unit will feed and transmit the documents. The START indicator light is on, and the light goes out after the transmission has been completed.

### Interrupting transmission:

Press the STOP/CLEAR button until a beep sounds. To eject the document, press the STOP/CLEAR button again.

2

## Redialing the last dialed number

If the line is busy or you wish to redial the last dialed number, press the REDIAL button.

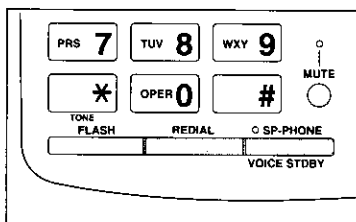

After pressing **SP-PHONE** or lifting the handset, press **REDIAL**.

```
<REDIALING>
1234567
```

### NOTES:

- When using the handset, the unit redials the number once.
- When using the speakerphone, the unit redials the number. If the line is busy, the unit will automatically redial the number. See the item number 8 on page 229. The SP-PHONE indicator light flashes and the following display is shown while waiting for the redialing:

```
AUG10 3:00PM 00 00
WAITING TO REDIAL
```

- To cancel the redialing, press the STOP/CLEAR button.

## Manual transmission (Case 2)

You can also access the other party's facsimile without using the handset or the SP-PHONE button.

This feature can transmit a document using less procedures.

1

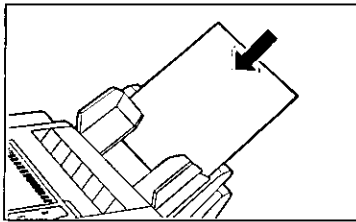

Insert the documents FACE DOWN.

A beep is heard.

– The unit can accept up to 20 pages at a time.

2

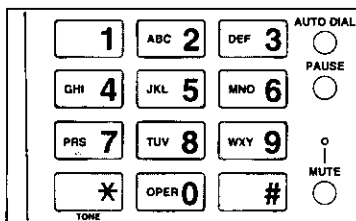

Enter the phone number of the receiving party.

**Example:** 1234567 is dialed.

AUG10 3:00PM 00 00
1234567

– Confirm in the display whether the phone number is correctly entered.

– If you misdialed, press **STOP/CLEAR**, then enter the correct number.

3

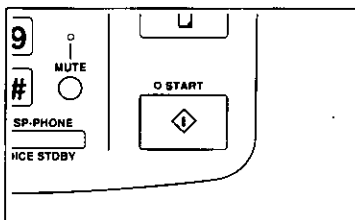

Press **START**.

The unit dials and transmits the documents. The START indicator light changes from flashing to steady.

### Interrupting transmission:

– Press the **STOP/CLEAR** button until a beep sounds. To eject the document, press the **STOP/CLEAR** button again.

### NOTES:

– If there is no answer or the line is busy, the unit will automatically redial the number. See the item number 7 on page 229.  
– To cancel the redialing, press the **STOP/CLEAR** button.

### HELPFUL HINTS for overseas transmission:

– Set the overseas transmission mode (see page 134).  
– When dialing the phone number, add two pauses at the end of the number by pressing the **PAUSE** button.

# Receiving Documents

---

## CAUTIONS:

- In order to avoid a paper jam, do not open the printer cover while printing.
- Do not load recording paper while the unit is feeding paper.

## Manual reception

### Receiving in the TEL mode and other modes:

You can receive fax messages manually as follows:

1

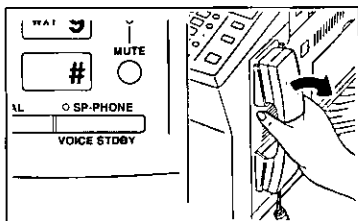

When the phone rings, lift the handset, or press **SP-PHONE** to answer the call.

- If pressing **SP-PHONE**, the SP-PHONE indicator light is on.

2

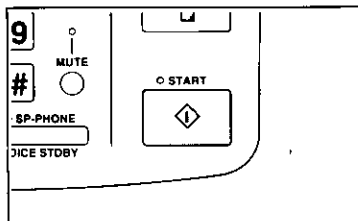

When a voice is heard and document reception is required or nothing is heard, press **START**.

The START indicator light is flashing.

3

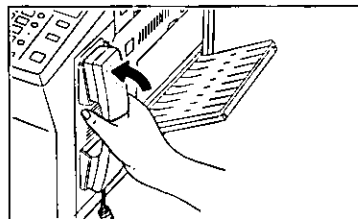

Place the handset on the cradle if using it.

The unit starts receiving the fax.

The START indicator light is on while receiving the fax, and the light goes out after the reception has been completed.

## NOTES:

- To interrupt reception, press the STOP/CLEAR button. The unit will stop receiving.
- If someone does not answer the call in the TEL mode within 15 rings, the unit will automatically switch to the ANS/FAX mode.

## Automatic reception

When receiving a fax call, the unit will automatically activate the fax function, then initiate reception.

Set the receiving mode to *ANS/FAX*, *TEL/FAX* or *FAX* mode.

### CAUTION:

- Do not let more than 70 sheets of 75 g/m<sup>2</sup> (20 lb.) paper accumulate at one time in the receiving tray. This may cause a paper jam.

### NOTE:

- While programming a function or printing a list, the unit will not receive documents automatically. In this case the unit will ring until you answer the call.

### Receiving in the *ANS/FAX* mode:

1

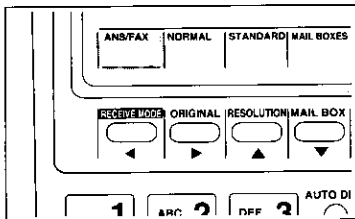

Make sure that the unit is in the *ANS/FAX* mode.

- The current receiving mode is shown on the display.

2

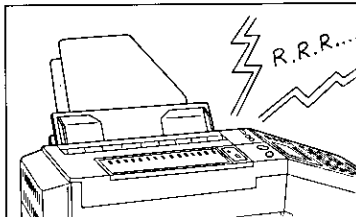

A call comes in.

- The unit will ring, depending on the setting of the rings in the *ANS/FAX* mode.  
You can change the ring count, see page 163.

3

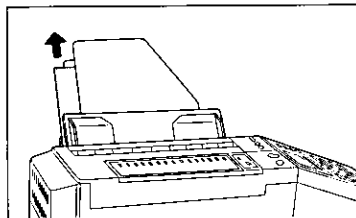

- When receiving a fax call, the unit automatically activate the fax function to receive documents.

- The START indicator light is on while receiving the fax-messages.

- When receiving a voice-call, the unit plays your greeting message for the *ANS/FAX* mode and will record an incoming voice message.

### HELPFUL HINT:

- If the other party wishes to leave a message and transmit a document on the same call, let them know the instructions on page 64 in advance.

### NOTES:

- A telephone fee is charged to callers from the moment the unit plays your greeting message.
- Begin by transmitting the leaflet found on page 241 to your associates. In this way you can inform the procedure for transmitting documents and/or recording voice-messages on your unit.

## Receiving in the TEL/FAX mode:

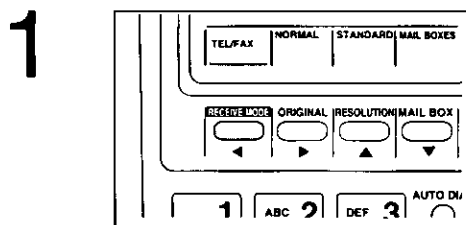

Make sure that the unit is in the *TEL/FAX* mode.

- The current receiving mode is shown on the display.

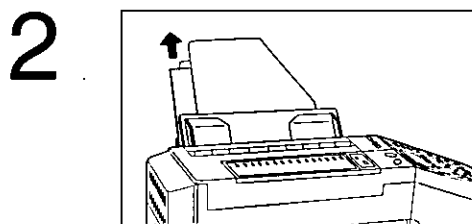

- **When receiving a fax call,** the unit automatically activates the fax function to receive the documents without ringing.

The **START** indicator light is flashing, and then the light is on while receiving the documents.

or

or

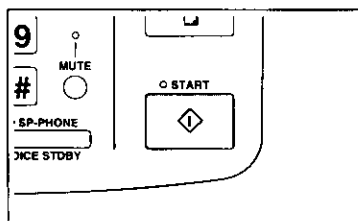

- **When receiving a voice call,** the unit plays your greeting message for the *TEL/FAX* mode and then rings depending on the setting of the silent fax recognition ring. You can change the ring count. See page 170.

- If a fax reception is required or nothing is heard after answering the call, press **START** to receive a fax. Then replace the handset if using it.
- If someone does not answer the call, the unit will automatically activate the fax function to receive documents.

### NOTES:

- A telephone fee is charged to callers from the moment the unit plays your greeting message.
- The unit can distinguish between a voice and fax call by detecting the calling tone (CNG), sent by the transmitting fax machines.  
Some fax messages that are transmitted manually may be received after the unit rings, because some fax machines do not send calling tone in manual mode.

Receiving in the FAX mode:

1

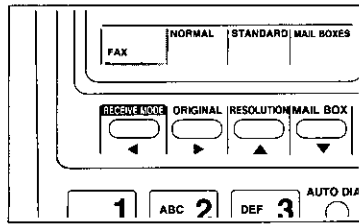

Make sure that the unit is in the *FAX* mode.

- The current receiving mode is shown on the display.

2

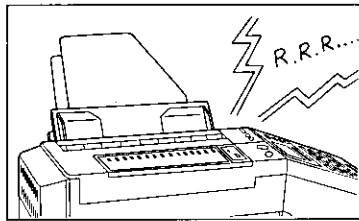

A call comes in.

- The unit answers the call after ringing, depending on the setting of the number of rings in the *FAX* mode.  
You can change the ring count. See page 170.

3

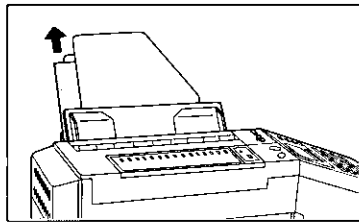

The unit produces a fax tone, then starts receiving the documents.

The *START* indicator light is flashing, and then the light is on while receiving the documents.



## Receiving over-sized documents

You may be sent a document that is longer than one 216 × 279 mm (8½" × 11") standard sheet of paper. In this case, the unit will automatically reduce the document in length to fit on one page or divide it into two or more pages when printing out.

### Printouts on letter-size paper:

<b>Incoming document transmitted</b>	<b>Letter-size</b> 216 × 279 mm (8½" × 11")	<b>A4 size</b> 210 × 297 mm (8¼" × 11⅙")	<b>Legal-size</b> 216 × 356 mm (8½" × 14")	<b>Longer than</b> 370 mm (14⅞")
	↓	↓	↓	↓
<b>Printout for receiving</b>	Reduced to 92%	Reduced to 86%	Reduced to 72%	Divided (First page)
				Divided (Second page)

### Printouts on legal-size paper:

<b>Incoming document transmitted</b>	<b>Letter-size</b> 216 × 279 mm (8½" × 11")	<b>A4 size</b> 210 × 297 mm (8¼" × 11⅙")	<b>Legal-size</b> 216 × 356 mm (8½" × 14")	<b>Longer than</b> 370 mm (14⅞")
	↓	↓	↓	↓
<b>Printout for receiving</b>	Not reduced	Not reduced	Reduced to 92%	Divided (First page)
				Divided (Second page)



**NOTES:**

- To extend the reduced document to actual size, see pages 171 and 173 and perform the extension copy.
- If you wish to receive documents in actual size, the automatic reduction feature can be turned off. For details, see page 175.

## ***Memory reception***

If the paper runs out or a paper jam occurs during a reception, the unit will temporarily store a continuation of the documents. The stored documents will be printed out automatically after the paper is supplied or the paper jam is cleared. While the unit keeps the documents in memory, a slow beep of the message alert will sound.

- Concerning the memory capacity for storing documents, see page 8 .

**NOTES:**

- If memory becomes full during a reception, the unit will stop receiving documents and display the following message:

```
AUG10  3:00PM 00 99
*** MEMORY FULL ***
```

Print the stored documents to clear the memory.

- If a power failure occurs or you turn the power switch off, all stored documents will be kept in memory for about one day by the back-up of the battery installed in the unit.

# Transmitting Documents Manually to Your Unit \_\_\_\_\_

## Leaving a message and transmitting documents on the same call

When the unit is in the *ANS/FAX* mode, your caller can follow the steps below to leave a message and send documents on the same call.

### ■ From a touch tone phone:

1



Your caller may call your unit, and then leave you a message after a long beep following your greeting message.

2

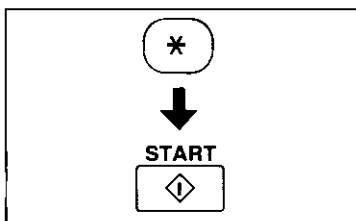

When the message is finished, they may press the asterisk key twice ( \* \* ) to change the unit to the fax mode.

They then may start transmission upon hearing the fax tone.

### ■ From a rotary (pulse) phone:

If the calling facsimile machine has a voice contact (call reservation) function, your caller can leave a voice-message after transmitting documents to your facsimile.

1

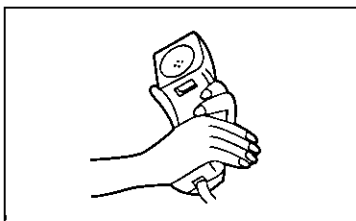

Your caller may call your unit, and then press the mute button or cover the mouthpiece of their handset for about 5 seconds to change the unit to the fax mode after the greeting message.

2

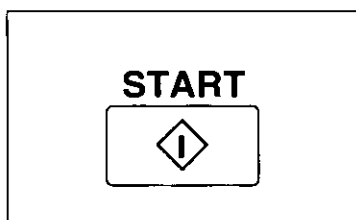

They then may start transmission upon hearing the fax tone by pressing their start or transmit button.

3

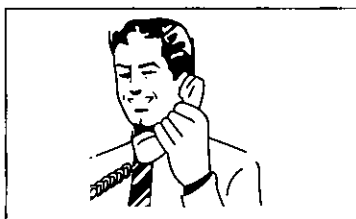

They may make a call reservation (e.g. pressing their call reservation button) during transmission.

Your unit plays the greeting message again.

They then may leave a message after a long beep following your greeting message.

## ***Transmitting documents with manual operation***

When the unit is the *ANS/FAX* mode, your caller may send documents as below.

### **■ From a touch tone phone:**

Your caller may call your unit, and then press the asterisk key twice ( \* \* ) during or after the greeting message to change the unit to the fax mode.

They then may start transmission upon hearing the fax tone by pressing their start or transmit button.

### **■ From a rotary (pulse) phone:**

Your caller may call your unit, and then press the mute button or cover the mouthpiece of their handset for about 5 seconds to change the unit to the fax mode after the greeting message.

They then may start transmission upon hearing the fax tone by pressing their start or transmit button.

# Making Copies

The unit can make single or multiple copies up to 70 sheets. Any transmissible document can be copied. See page 52.

## CAUTION:

- In order to avoid a paper jam, do not open the printer cover while printing.

1

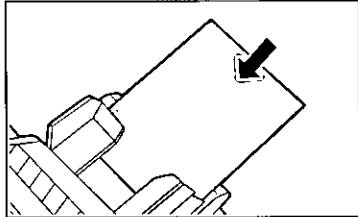

Insert the documents **FACE DOWN**.

- The unit can accept up to 20 pages at a time.
- You can set the contrast and resolution modes. See page 53.

2

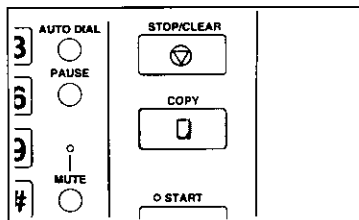

Press **COPY**.

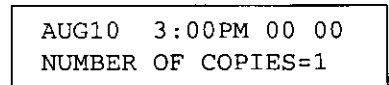

- If you need more than two copies, enter the number of copies (up to 70).

3

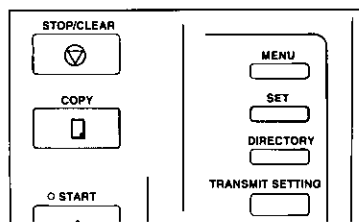

Press **COPY** or **SET**.

The unit feeds the documents, and then starts making copies.

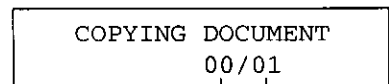

Printed pages —  
Number of copies —

## Interrupting a copy:

Press the **STOP/CLEAR** button while making copies until a beep is heard. To eject the document, press the **STOP/CLEAR** button again.

## NOTES:

- When copying, the unit automatically selects the fine resolution, but you may use the halftone resolution.
- If you wish to copy 21 or more pages at a time, insert the first 20 pages of the document and add the extra pages up to 20 pages at a time, before the last page is fed into the unit.
- You can make or receive voice calls while making copies.
- While activating the fax communication, the unit cannot make copies.
- While making copies, the unit cannot activate the automatic reception.

# Operating the Answering Device

The unit also works as an automatic telephone answering and recording system. When the unit answers a call in the *ANS/FAX* mode, the caller hears your greeting message for the *ANS/FAX* mode, and then the unit starts recording the caller's message.

The unit can save 10 minutes of incoming messages, memo message (see page 73), telephone conversation (see page 74) and greeting messages.

## NOTES:

- If the incoming messages are noisy, the recording time might be less than 10 minutes.
- While activating the fax function, you cannot operate the answering device.
- When a fax transmission or telephone operation takes place while operating the answering device, your operation of the answering device will be interrupted.

## Setup of voice message and document reception

1

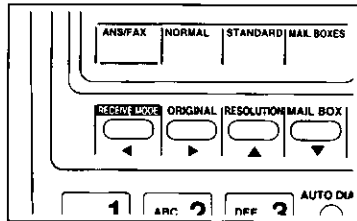

Make sure that the unit is in the *ANS/FAX* mode.

- The current receiving mode is shown on the display.

2

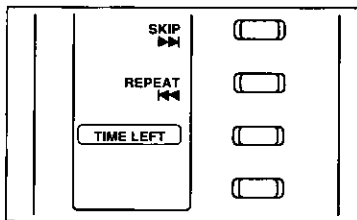

(Inside the station key cover)

Press **TIME LEFT** to confirm the time left for recording of incoming messages.

```
AUG10  3:00PM 00 00
TIME LEFT = 8m30s
```

(Example: 8m30s means 8 minutes and 30 seconds)

- Press **TIME LEFT** again or **STOP** to clear the display.
- When a call is received, the unit answers the call and begins playback of your greeting message for the *ANS/FAX* mode.
- The unit automatically distinguishes between voice and fax calls, and then functions as an answering device and/or a facsimile.

## NOTES:

- The recording time for incoming messages can be set to "unlimited" (pre-selected setting) or "1 minute". To change the recording time, see page 165.
- When the remaining time is little, erase useless messages from memory. See page 72.
- When there is no room left in memory to record a message, the display shows the following message. Erase some or all messages (see page 72).

```
JAN 1  12:00AM 10 00
... MESSAGE FULL ...
```

## ***Monitoring incoming calls***

While an incoming message is being recorded, you can monitor the caller's voice through the built-in speaker. Adjust the sound level using the VOLUME control (  $\Delta$  or  $\nabla$  ) button.

To answer the call while monitoring, lift the handset or press the SP-PHONE button. The unit stops recording automatically.

# Listening to Recorded Messages

When new incoming messages have been recorded, the call counter shows the number of recorded messages up to 99, and the voice-message indicator flashes.

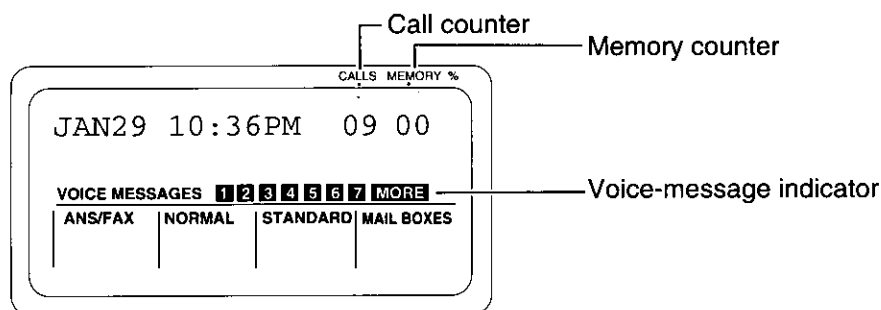

Flashing number means that there are new messages which have not been listened to yet. When more than 8 messages are recorded, "MORE" is flashing.

When you listen to the recorded messages, you can adjust the volume level of the speaker by pressing the VOLUME control button ( $\Delta$ ,  $\nabla$ ).

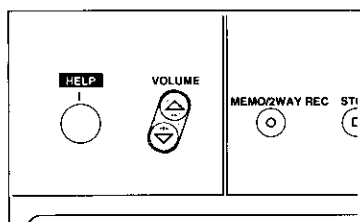

To raise the volume level, press  $\Delta$ .  
To lower, press  $\nabla$ . 8 levels are adjustable. The volume level is shown on the display as follows:

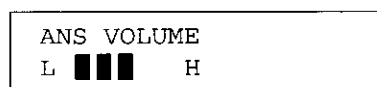

## NOTE:

- If the volume level is too low, nothing can be heard during playback.  
Raise the volume level.

## Listening to newly recorded messages

You can play back newly recorded messages. Messages once reviewed will not be played back.

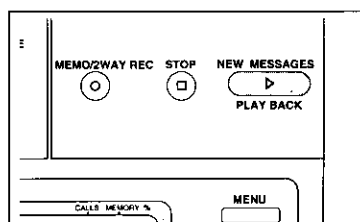

Press **NEW MESSAGES PLAYBACK**.

The unit plays back new messages. During the playback, the display shows the message number and the time when the message was recorded, as example below.

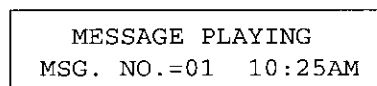

At the end of the last message, 3 beeps sound.

## Listening to all the recorded messages

All the recorded messages will be played back from the first message.

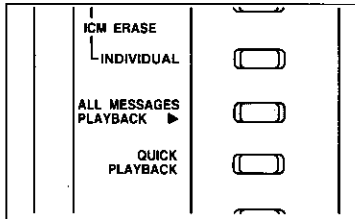

Press **ALL MESSAGES PLAYBACK**.

The unit plays back all the recorded messages.

During the playback, the display shows the message number and the time when the message was recorded, as example below.

MESSAGE PLAYING  
MSG. NO.=01 10:25AM

At the end of the last message, 3 beeps sound.

## Functions during the message playback

To repeat a message:

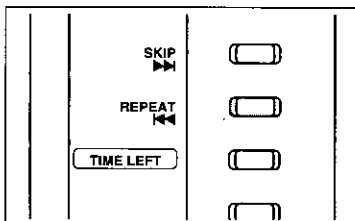

Press **REPEAT** to play back the previous message.

To skip a message:

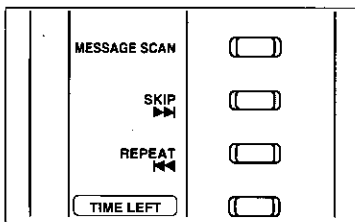

Press **SKIP** to skip to the next message.



To play back quickly:

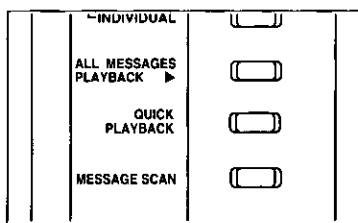

Press **QUICK PLAYBACK**.

QUICK PLAYING  
MSG. NO.=01 10:25AM

– To return to the normal speed, press **QUICK PLAYBACK** again.

To stop playback:

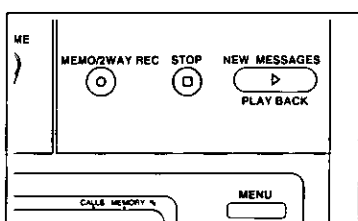

Press **STOP**.

– You can resume another operation for answering device.

## Listening to the beginning of each recorded message

In order to know what messages are recorded, you can listen to the first few seconds of every recorded messages one after another.

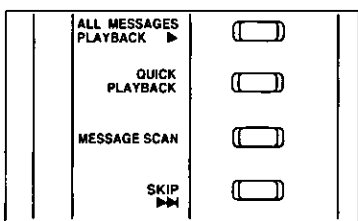

Press **MESSAGE SCAN**.

During the playback, the display shows the message number and the time when the message was recorded, as example below.

MESSAGE SCAN  
MSG. NO.=01 10:25AM

At the end of the last message, 3 beeps sound.

## Saving messages

The unit saves the incoming messages automatically, if you do not erase them. After playback, the voice message indicator will show the number of messages in memory.

# Erasing Recorded Messages

## Erasing specific messages from memory

You may erase specific messages.

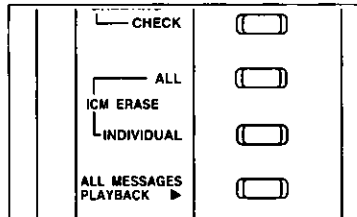

Press **ICM ERASE-INDIVIDUAL** while the message you want to erase is playing.

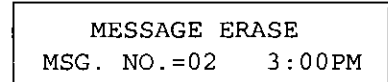

After erasing the message, the unit plays the next message.

- The followed numbers of the voice-message indicator go up by one.

## Erasing all messages from memory

You may erase all the recorded messages. Your greeting messages for both the *ANS/FAX* mode and *TEL/FAX* mode are not erased in this operation.

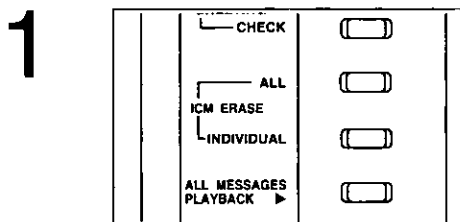

Press **ICM ERASE-ALL** after listening to all the messages.

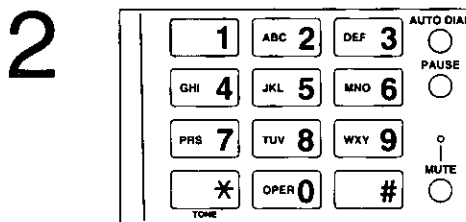
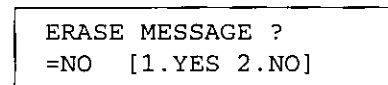

Press **1**.

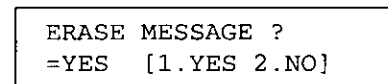

- To interrupt this feature, press 2 or press **STOP**.

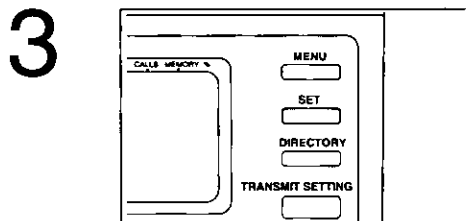

Press **SET** to start erasing.

All the recorded messages are erased.

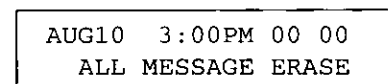

- The call counter shows "00" and the voice-message indicator goes out.

# Recording a Memo Message

If you are going out and want to leave a private message for someone, you can record a voice memo in the unit. This can be played back afterward either directly or remotely, exactly like any other incoming message.

1

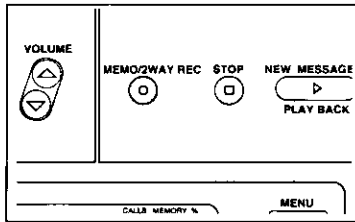

Press **MEMO/2WAY REC** to start recording a memo message.

A beep is heard.

```
AUG10  3:00PM 00 00
MEMO RECORDING
```

2

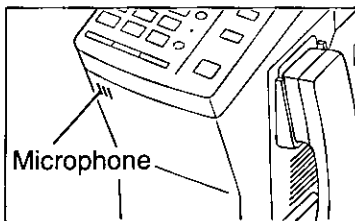

Speak immediately after the beep about 200 mm (8 inches) away from the microphone.

3

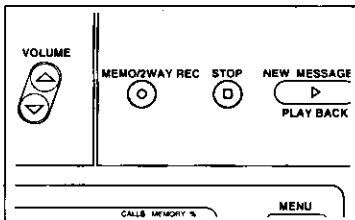

To stop recording, press **MEMO/2WAY REC** again or **STOP**.

```
AUG10  3:01PM 01 00
```

– The call counter increases by one and the number of the voice-message indicator flashes.

## NOTE:

- When memory becomes full while recording, the unit stops recording automatically and 6 beeps are heard. Erase some or all messages. See page 72.

2

# Recording a Telephone Conversation

While speaking with someone on the telephone, you can record your conversation. And afterward, you can play back either directly or remotely, exactly like any other incoming message.

1

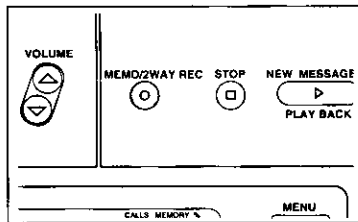

During your conversation, press **MEMO/2WAY REC** to start recording.

A beep is heard.

AUG10 3:00PM 00 00  
2WAY RECORDING

2

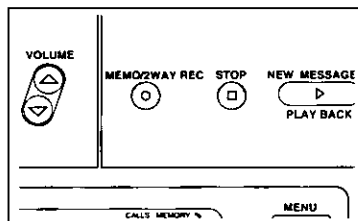

To stop recording, press **MEMO/2WAY REC** again or **STOP**.

or

Hang up after the conversation.

– The call counter increases by one and the number of the voice-message indicator flashes.

AUG10 3:03PM 01 00

## NOTES:

- There may be imposed regulations in your area (state) concerning the manner in which 2-way telephone conversations may be recorded. So you should inform the other party that the conversation is being recorded. Consult your local telephone company for further information.
- When memory becomes full while recording, the unit stops recording automatically and 6 beeps are heard. Erase some or all messages. See page 72.

# Making and Answering Voice Calls

## Making voice calls

### Using the handset:

1. Lift the handset and listen for the dial tone.
2. Dial the phone number.
3. When finished, replace the handset on the cradle.

AUG10 3:00PM 00 00  
ENTER PHONE NUMBER

### Using speakerphone operation:

1

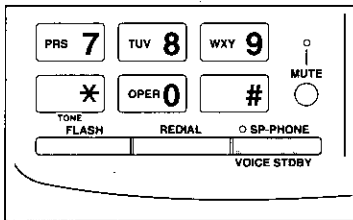

Press **SP-PHONE** and listen for the dial tone.

The SP-PHONE indicator light is on.

AUG10 3:00PM 00 00  
ENTER PHONE NUMBER

2

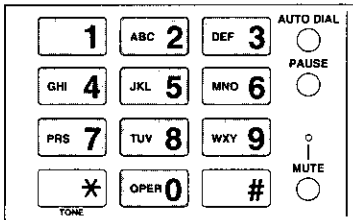

Dial the phone number.

The dialed number is displayed.

**Example:** 1234567 is dialed.

AUG10 3:00PM 00 00  
1234567

3

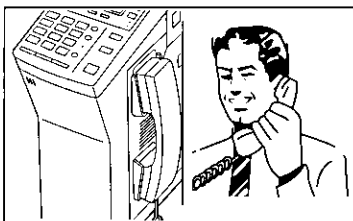

When the other party answers your call, speak with them through the microphone, or lift the handset and talk into it.

4

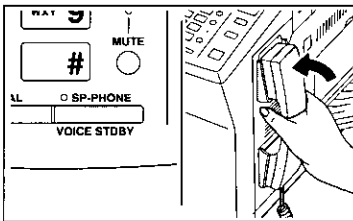

When finished, press **SP-PHONE**, or replace the handset on the cradle.

#### HELPFUL HINTS:

- Use the speakerphone in a quiet room for the best performance.
- If the other party has difficulty hearing you, adjust the volume using the VOLUME control. (See page 76.)
- If you and the other party speak at the same time, parts of your conversation will be lost. To avoid this, speak alternately.

## Adjusting the volume level:

You can adjust the volume level of the handset receiver or speaker by pressing the VOLUME control button (  $\Delta$ ,  $\nabla$  ). When using the handset, 3 levels are available (High, Rather High, and Normal). When using speakerphone operation, 8 levels are available. The volume level is shown on the display as follows:

### To raise the volume level:

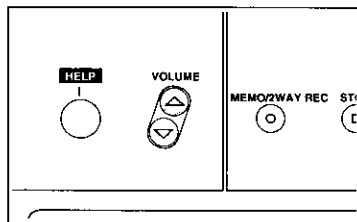

Press  $\Delta$ .

– Each press of  $\Delta$  increases one black square mark on the display.

When using the handset:

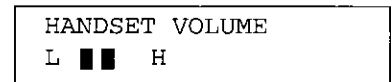

When using speakerphone operation:

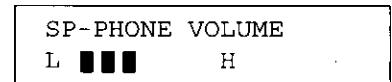

### To lower the volume level:

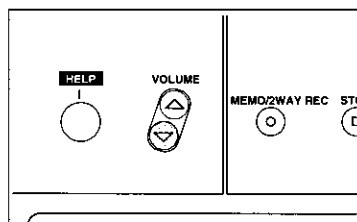

Press  $\nabla$ .

– Each press of  $\nabla$  decreases one black square mark on the display.

When using the handset:

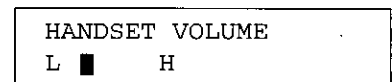

When using speakerphone operation:

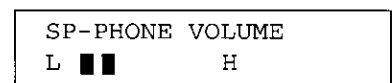

### NOTE:

– After hanging up, the selected volume level will be maintained.

If you misdial:

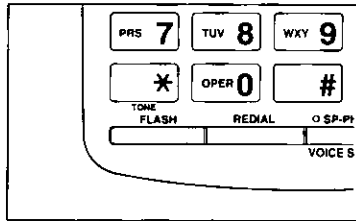

Press **FLASH** firmly before the other party answers.

The dial tone will sound, and dial the correct number.

## Redialing the last dialed number

If the line is busy or you wish to redial the last dialed number, press the REDIAL button.

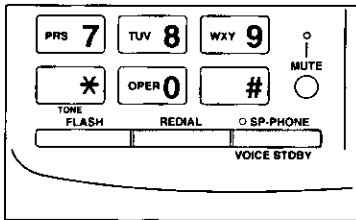

After pressing **SP-PHONE** or lifting the handset, press **REDIAL**.

<REDIALING>  
1234567

### NOTES:

- When using the handset, the unit redials the number once.
- When using speakerphone operation, the unit redials the number. If the line is busy, the unit will automatically redial the number. See the item number 8 on page 229. The SP-PHONE indicator light flashes and the following display is shown while waiting for the redialing.

AUG10 3:00PM 00 00  
WAITING TO REDIAL

- To cancel the redialing, press the STOP/CLEAR button.

## Answering voice calls

1. When the phone rings, lift the handset, or press the SP-PHONE button to answer the call.
2. When finished, replace the handset on the cradle, or press the SP-PHONE button.

### NOTES:

- For helpful hints for the speakerphone operation, see page 75.





# **Chapter 3**

## *Advanced Instructions*



# Storing Phone Numbers for Automatic Dialer

The unit's memory allows you to use both one-touch dialing (up to 28 phone numbers) and speed dialing (up to 100 phone numbers) for rapid access to the most frequently dialed numbers.

## HELPFUL HINT:

- If you lose your instructions while programming, press the HELP button. The unit will print information on how to program.

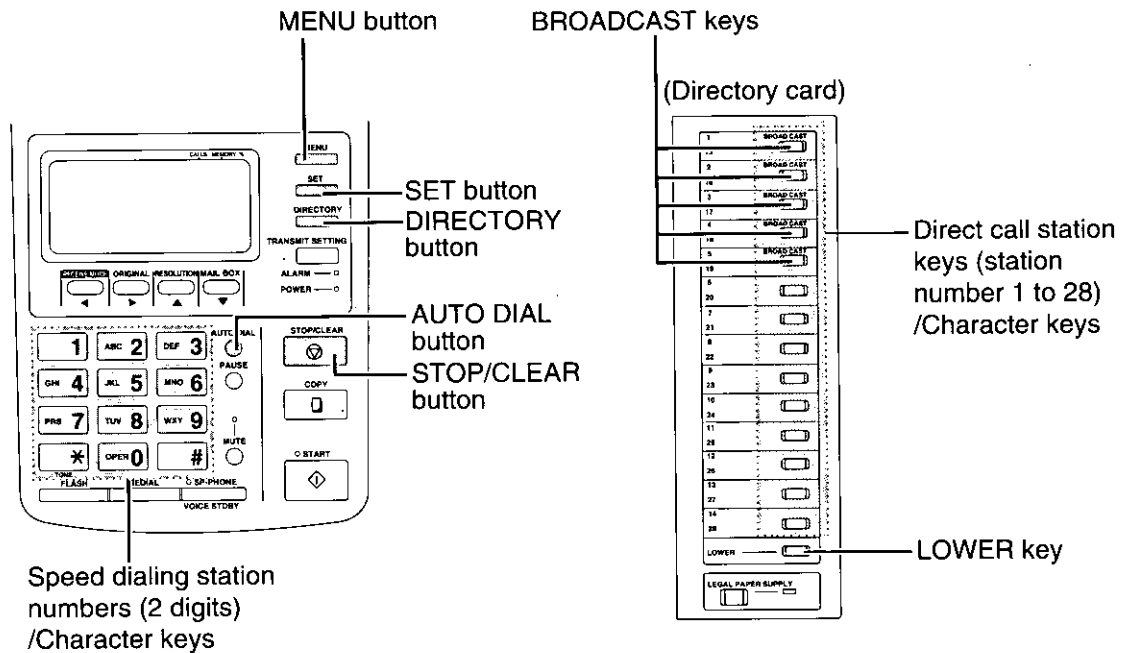

## NOTE:

- When you store a phone number for automatic dialer (see pages 81 to 88), turn the directory card over. You will find the character layout and command keys.

## Filling in the directory card

1. Remove the clear cover using an instrument with a pointed end, like a pen or pin, as shown below.
2. Remove the directory card.
3. Write in the names associated with the direct call station keys.
4. Re-install the directory card and the cover.

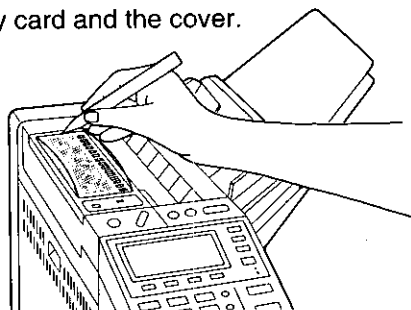

## Storing phone numbers for one-touch dialing

You can store up to 28 telephone numbers and station names into the direct call station keys consisting of the upper stations (station numbers 1 to 14) and the lower stations (station numbers 15 to 28).

Each phone number can be programmed up to 30 digits in length.

Each station name can be programmed up to 16 characters.

The stored telephone numbers and names are also automatically stored in the electronic telephone directory (see page 94).

1

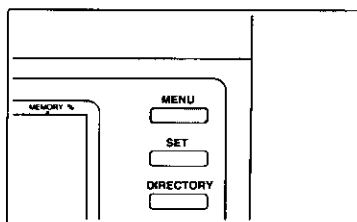

Press **MENU** until the following is shown.

PROG. [1.DATE 2.TEL  
3.SYSTEM 4.REPORT]

2

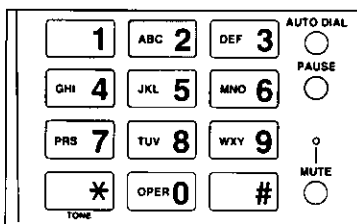

Press **2** to start programming.

SELECT AUTO OR  
DIRECT CALL KEY

3

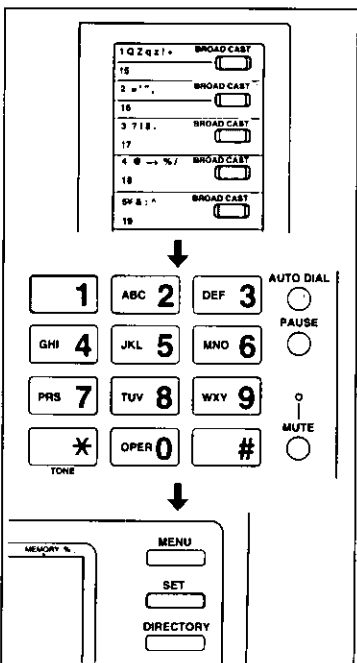

Press one of the direct call station keys where you want to store the phone number.

■ **When using the station numbers 1 to 5:**

1. Press the desired **BROADCAST** (1 to 5).

**Example:** The station number is 1.

BRDCAST.1 MODE=DIAL  
[1.DIAL 2.PROG.]

2. Press 1.

– If you wish to store the multistation into **BROADCAST**, press 2 instead of 1 (see page 83).

3. Press **SET**.

ENTER TEL NO.<S01>  
=

or

or

(continued)

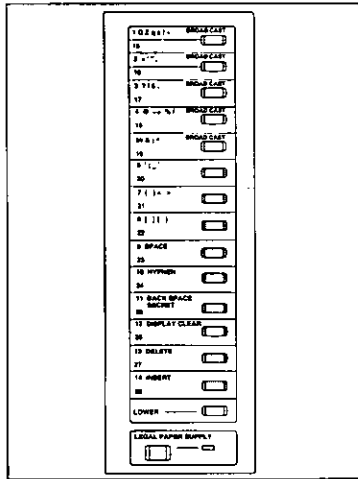

■ When using the upper station numbers 6 to 14:

Press the direct call station key (6 to 14)

**Example:** The station number is 6.

ENTER TEL NO.<S06>  
=

or

■ When using the lower station numbers 15 to 28:

Press **LOWER**, then press the direct call station key (15 to 28).

**Example:** The station number is 15.

ENTER TEL NO.<S15>  
=

4

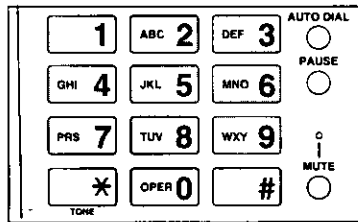

Enter the phone number.

**Example:** The station number is 6, and the phone number is 7654321.

ENTER TEL NO.<S06>  
=7654321

- To insert a hyphen into the number, press **HYPHEN** (direct call station "10") while entering the number.
- HYPHEN is counted as 2 digits.

5

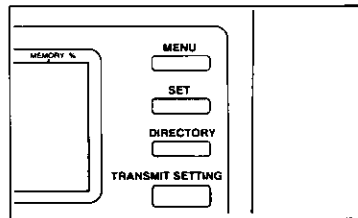

Press **SET** to store the program into memory.

ENTER NAME  
=

6

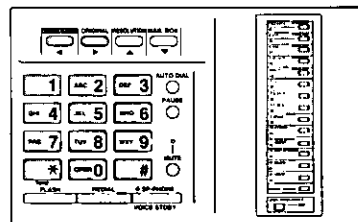

Enter the name associated with the direct call station by using the dial keypad and the direct call station keys as character keys, and the cursor key (◀ or ▶).

- For further details of the character keys, see page 47.

7

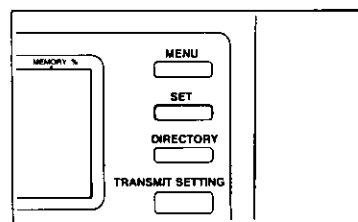

Press **SET** to store the program into memory.

SELECT AUTO OR  
DIRECT CALL KEY

- To store other phone numbers, repeat steps 3 through 7.

# 8

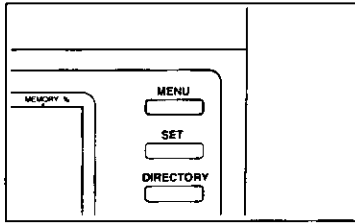

After storing the numbers, press **MENU** to end the operation.

– To transmit documents by one-touch dialing, see page 97.

**NOTES:**

- To correct an error while programming before pressing the SET button, press the STOP/CLEAR button, then try again.
- To cancel the programming halfway, press the MENU button.
- You can confirm that you have correctly stored phone numbers with the telephone number list (see page 92).

**HELPFUL HINT for overseas transmission:**

- When storing the phone number, add two pauses at the end of the number by pressing the PAUSE button (see page 153).

## Storing multistations for one-touch dialing

The unit has 5 BROADCAST keys. Each key is used to program and store more than one station (multistation transmission), as well as a phone number in a direct call station key. This is very useful when frequently sending the same documents to fixed parties.

If you store the phone number by using a full number, only one station will be acceptable. So, before you start programming, make sure that the desired phone numbers have been stored into the direct call stations or speed dial stations (see pages 81 and 85).

The BROADCAST keys can also be used as the direct call station keys 1 to 5, but they cannot be used for two purposes. For example, if the direct call station number 1 has already been used for a phone number, it cannot be used as the broadcast number 1.

# 1

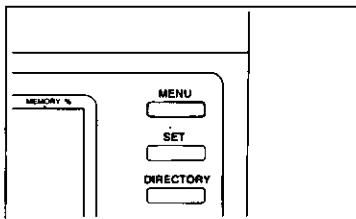

Press **MENU** until the following is shown.

PROG. [1.DATE 2.TEL  
3.SYSTEM 4.REPORT]

# 2

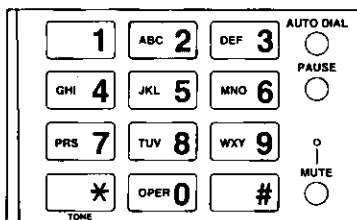

Press **2** to start programming.

SELECT AUTO OR  
DIRECT CALL KEY

(continued)

3

3

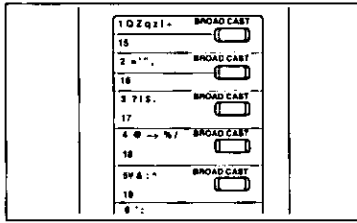

Press the desired **BROADCAST** (1 to 5).

**Example:** The broadcast number is 1.

```
BRDCAST.1 MODE=DIAL
[1.DIAL 2.PROG.]
```

4

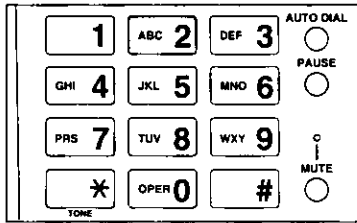

Press **2**.

```
BRDCAST.1 MODE=PROG
[1.DIAL 2.PROG.]
```

– If you use this key as a direct call station key, press **1** instead of **2**. See page 81.

5

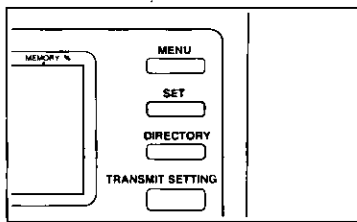

Press **SET** to store your selection into memory.

```
ENTER PHONE NUMBER
= [001]
```

6

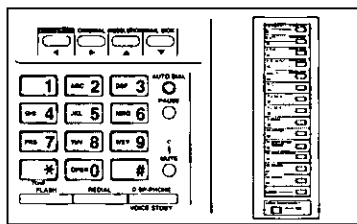

Enter the phone number by using the direct call station key or the speed dial station.

**Example:** The phone number is the direct call station 6.

```
ENTER PHONE NUMBER
=<S06> [001]
```

**NOTE:**

– When entering the phone number by using a full number, only one station will be acceptable.

7

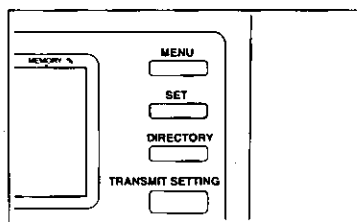

Press **SET** to store the number into memory.

```
ENTER PHONE NUMBER
= [002]
```

– To enter other phone numbers, repeat steps 6 and 7 (up to 127 stations).

8

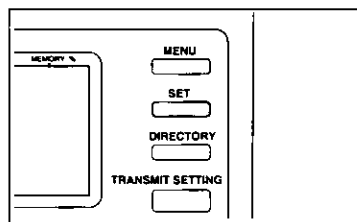

Press **SET** again after entering all the desired phone numbers.

```
SELECT AUTO OR
DIRECT CALL KEY
```

9

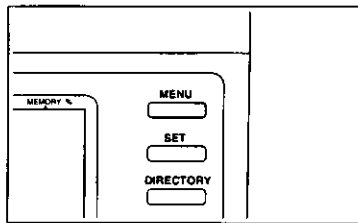

Press **MENU** to end the operation.

- To transmit documents by using **BROADCAST**, see page 98.

**NOTES:**

- To correct an error while programming, press the STOP/CLEAR button, then try again.
- To cancel the programming halfway, press the MENU button.
- You can confirm that you have correctly stored your programming with the telephone number list (see page 92).

### Storing phone numbers for speed dialing

The unit is equipped with 100 stations (00 to 99) for speed dialing, each of which can store a phone number and a station name .

Each phone number can be programmed up to 30 digits in length.

Each station name can be programmed up to 16 characters.

The stored telephone numbers and names are also automatically stored in the electronic telephone directory (see page 94).

1

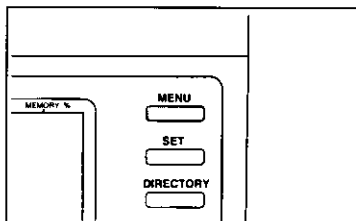

Press **MENU** until the following is shown.

```

PROG. [1.DATE 2.TEL
3.SYSTEM 4.REPORT]
  
```

2

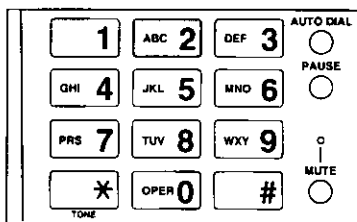

Press **2** to start programming.

```

SELECT AUTO OR
DIRECT CALL KEY
  
```

3

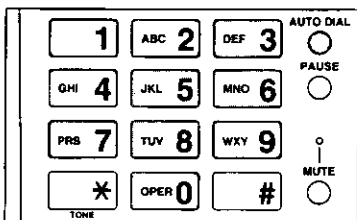

Press **AUTO DIAL**.

Then enter the 2-digit number (00 to 99).

**Example:** The station number is 00.

```

ENTER TEL NO. <A00>
=
  
```

(continued)

4

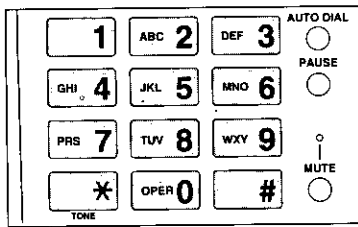

Enter the phone number.

**Example:** The phone number is 1234567.

ENTER TEL NO.<A00>  
=1234567

- To insert a hyphen into the number, press **HYPHEN** (direct call station "10") while entering the number.
- HYPHEN is counted as 2 digits.

5

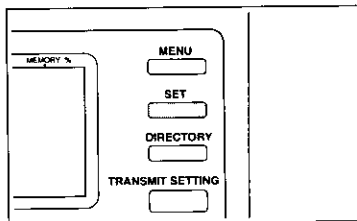

Press **SET** to store the program into memory.

ENTER NAME  
=

6

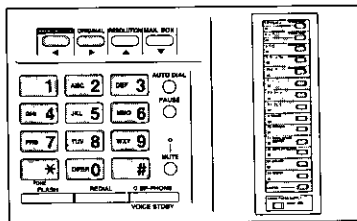

Enter the name associated with the speed dial station by using the dial keypad and the direct call station keys as character keys, and the cursor key (◀ or ▶).

- For further details of the character keys, see page 47.

7

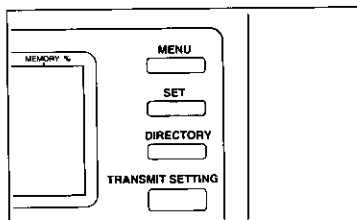

Press **SET** to store the program into memory.

SELECT AUTO OR  
DIRECT CALL KEY

- To store other phone numbers, repeat steps 3 through 7.

8

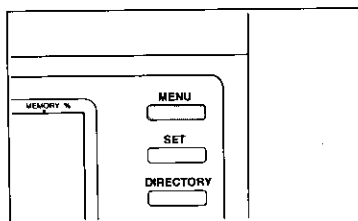

After storing the numbers, press **MENU** to end the operation.

- To transmit documents by speed dialing, see page 97.

**NOTES:**

- To correct an error while programming before pressing the SET button, press the STOP/CLEAR button, then try again.
- To cancel the programming halfway, press the MENU button.
- You can confirm that you have correctly stored phone numbers with the telephone number list (see page 92).

**HELPFUL HINT for overseas transmission:**

- When storing the phone number, add two pauses at the end of the number by pressing the PAUSE button (see page 153).



## Storing secret phone numbers

This function is useful for keeping a whole phone number or a portion of a phone number secret. When a list of the stored numbers is printed, secret numbers will not be printed.

The stored telephone numbers and names are also automatically stored into the electronic telephone directory (see page 94).

1

Proceed with steps 1 through 3 on page 81 for one-touch dialing or on page 85 for speed dialing.

**Example:** The direct call station key 7 is selected.

```
ENTER TEL NO.<S07>
=
```

2

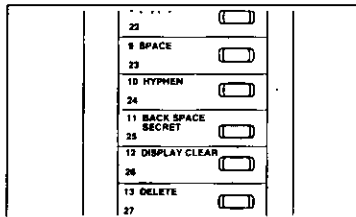

Press **SECRET** (direct call station "11") at the beginning of the number which you want to keep secret, then enter the number.

**Example:** 9876543 is a secret number.

"[" is displayed representing the start position of the secret number.

```
ENTER TEL NO.<S07>
=[9876543
```

– Pressing **SECRET** once counts as 2 digits.

3

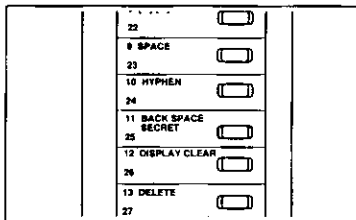

Press **SECRET** at the end of the number.

"]" is displayed representing the ending position of the secret number.

```
ENTER TEL NO.<S07>
=[9876543]
```

4

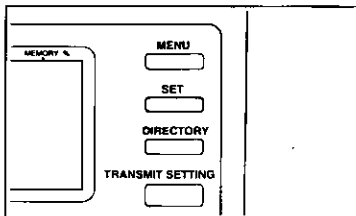

Press **SET** to store the number into memory.

```
ENTER NAME
=
```

(continued)

3

5

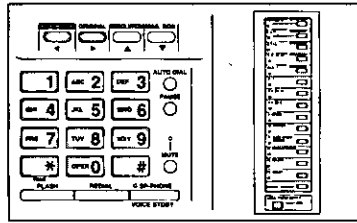

Enter the station name by using the dial keypad and the direct call station keys as character keys, and the cursor key (◀ or ▶).

– For further details of the character keys, see page 47.

6

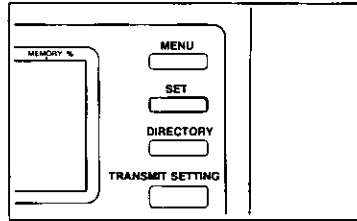

Press **SET** to store the program into memory.

SELECT AUTO OR  
DIRECT CALL KEY

– To store other phone numbers, repeat steps 1 to 6.

7

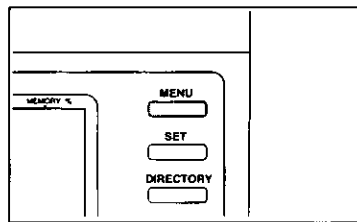

Press **MENU** to end the operation.

**NOTES:**

- To correct an error while programming before pressing the SET button, press the STOP/CLEAR button, then try again.
- To cancel the programming halfway, press the MENU button.

# Erasing Stored Phone Numbers

You may erase the stored phone numbers in the direct call station keys and speed dial stations.

The erased telephone number and station name are also automatically erased from the electronic telephone directory.

1

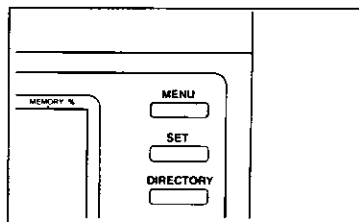

Press **MENU** until the following is shown.

```

PROG. [1.DATE 2.TEL
        3.SYSTEM 4.REPORT]
    
```

2

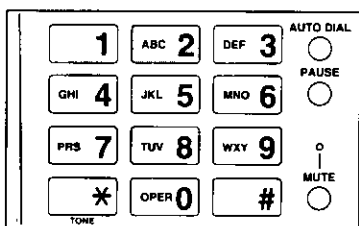

Press **2** to start programming.

```

SELECT AUTO OR
DIRECT CALL KEY
    
```

3

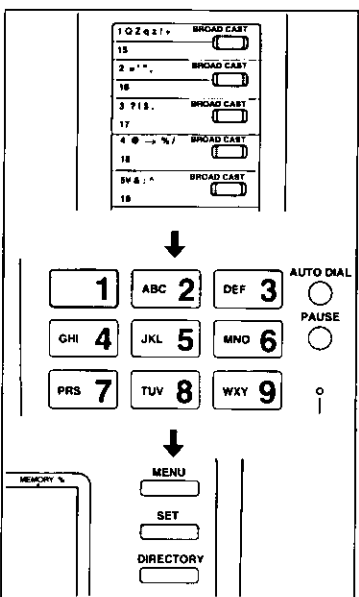

■ Erasing the phone number in the direct call station numbers 1 to 5 (broadcast keys 1 to 5):

1. Press the desired **BROADCAST** (1 to 5).  
**Example:** The broadcast number is 2.

```

BRDCAST.2 MODE=DIAL
[1.DIAL 2.PROG.]
    
```

2. Press **1**.
3. Press **SET**.

The display shows the stored phone number.

**NOTE:**

- If you have stored the multistation into the selected broadcast number, the display will not show the number. Skip step 4 and go to step 5.

or

or

(continued)

3

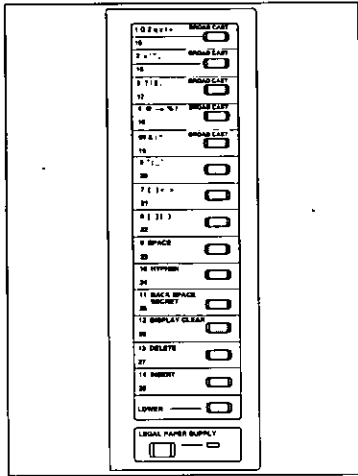

■ Erasing the phone number in the direct call station numbers 6 to 28:

Press the direct call station key.

- To erase the station numbers 15 to 28, press **LOWER** and the direct call station key.

The display shows the stored phone number.

OR

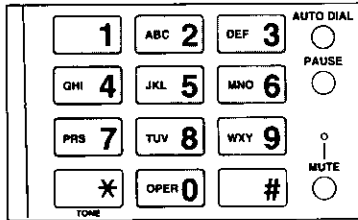

OR

■ Erasing the phone number in the speed dial station:

Press **AUTO DIAL** and then enter the desired 2-digit number (00 to 99).

The display shows the stored phone number.

4

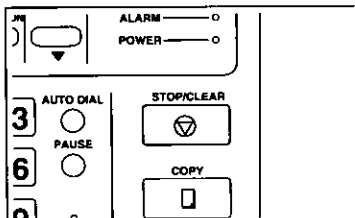

Press **STOP/CLEAR** to delete the phone number.

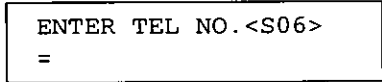

5

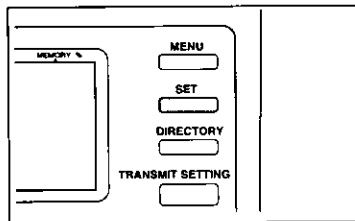

Press **SET**.

The display shows the stored station name.

- If a broadcast number is selected at step 3 into which the multistation has been stored, the display will not show the station name. Skip step 6 and go to step 7.

6

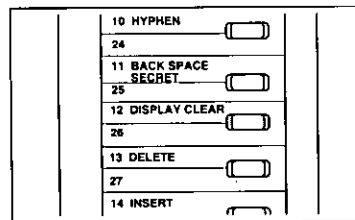

Press **DISPLAY CLEAR** (direct call station "12") to delete the station name.

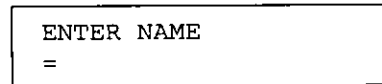

7

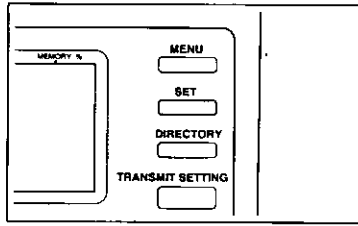

Press **SET** to erase the phone number and the station name from memory.

SELECT AUTO OR  
DIRECT CALL KEY

– To erase other phone numbers, repeat step 3 through 7.

8

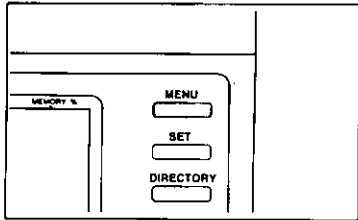

After erasing the numbers, press **MENU** to end the operation.

**NOTE:**

– To cancel the programming halfway, press the MENU button. The phone number and the station name will remain in memory.

3

# Printing Stored Phone Number List

The unit can print a list of the numbers programmed for one-touch dialing and speed dialing. Use this feature to confirm correctly stored phone numbers. To print the list, see page 93.

## Sample of the telephone number list:

```

***** TELEPHONE NUMBER LIST *****
<< AUTO KEY LIST >>
-----
PHONE NUMBER      NAME      PHONE NUMBER      NAME
00
01
02
03
04
05
06
07
08
09
10
50
51
52
53
54
55
56
57
58
59
60
    
```

```

***** TELEPHONE NUMBER LIST *****
<< BROADCAST KEY LIST >>

* BROADCAST 1 *
  01 KEY MODE      = PROGRAM
  02 PHONE NUMBER  = 506,510,000

* BROADCAST 2 *
  01 KEY MODE      = DIAL
  02 PHONE NUMBER  =
  03 NAME          =

* BROADCAST 3 *
  01 KEY MODE      = DIAL
  02 PHONE NUMBER  =
  03 NAME          =

* BROADCAST 4 *
  01 KEY MODE      = DIAL
  02 PHONE NUMBER  =
  03 NAME          =

* BROADCAST 5 *
  01 KEY MODE      = DIAL
  02 PHONE NUMBER  =
  03 NAME          =

<< STATION KEY LIST >>
-----
PHONE NUMBER      NAME      PHONE NUMBER      NAME
06 R7654321      MAIN OFFICE  18
07 R[ ]          MARY       19
08 T5551234      Panasonic   20
09 R9P0925554433 DEF Company  21
10 R2345678      WEST BRANCH 22
11
12
13
14
23
24
25
26
    
```

### Codes in each phone number:

- T: The telephone number has been entered in the tone dialing mode.
- R: The telephone number has been entered in the pulse (rotary) dialing mode.
- P: The pause has been entered.
- F: The flash has been entered.
- : The hyphen has been entered.
- [ ]: The secret phone number has been entered. (The telephone number is not printed.)

## Printing the telephone number list

1

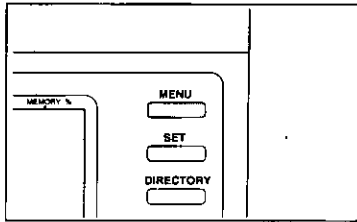

Press **MENU** until the following is shown.

PROG. [1.DATE 2.TEL  
3.SYSTEM 4.REPORT]

2

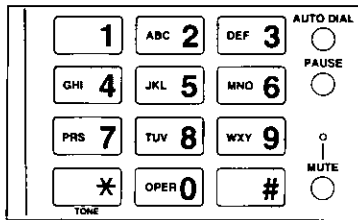

Press **4** to activate the printing function.

SELECT NO. [1.SYSTEM  
2.TEL NO. 3.JOURNAL]

3

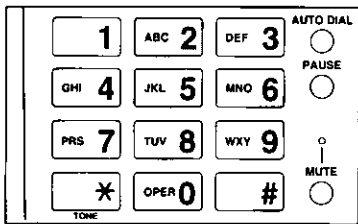

Press **2** to print the telephone number list.

The unit starts printing.

PRINTING PHONE LIST

4

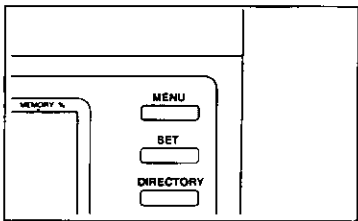

After printing, press **MENU** to end the operation.

### NOTE:

- To stop printing while the first page is printed out, press the STOP/CLEAR button until a beep is heard. The second page is not printed out.

3

# Electronic Telephone Directory

## Before using the electronic telephone directory

The telephone numbers and their associated names, stored for the automatic dialer, are automatically registered in the electronic telephone directory in alphabetical order. You can transmit a document or make a voice call by selecting the desired name from the electronic telephone directory. This is useful when you have forgotten the station number of the party you wish to call.

See pages 81 to 88 for storing phone numbers.

### Stored data (example)

#### One-touch dialing

ENTER TEL NO.<S06> =7654321
ENTER NAME =MAIN OFFICE

ENTER TEL NO.<S10> =2345678
ENTER NAME =WEST BRANCH

#### Speed dialing

ENTER TEL NO.<A00> =1234567
ENTER NAME =Anthony

ENTER TEL NO.<A50> =8765432
ENTER NAME =Judy

ENTER TEL NO.<A72> =5432109
ENTER NAME =Margaret

#### Secret phone number for one-touch dialing

ENTER TEL NO.<S07> =[9876543]
ENTER NAME =MARY

### Electronic telephone directory

Stored names are registered in alphabetical order.

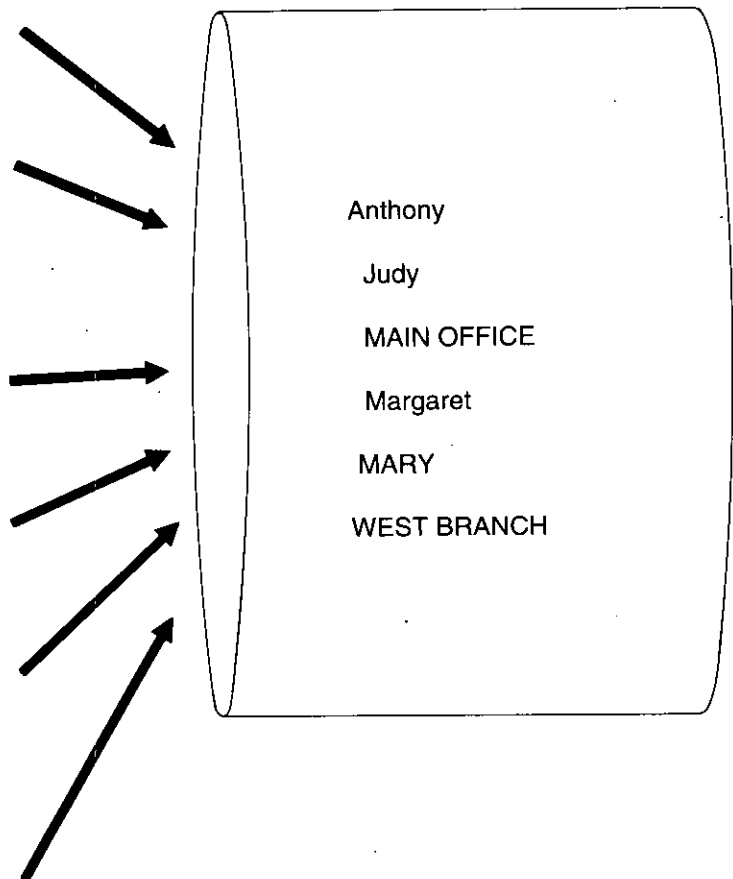

### NOTES:

- Be sure to enter the names with the stored phone numbers before using the electronic telephone directory.
- To transmit documents by using the electronic telephone directory, see page 100.
- To make voice calls by using the electronic telephone directory, see page 147.



## How to use the electronic telephone directory

### HELPFUL HINT:

- If you lose your instructions while operating, press the HELP button. The unit will print information on how to operate.

**Example:** You call "MARY" whose number is stored into memory associated with the direct call station 7.

1

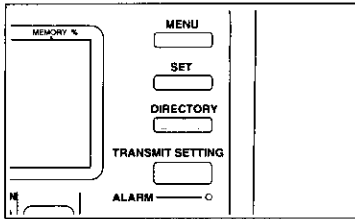

Press **DIRECTORY**.

SELECT INDEX  
A-Z, 0-9, #

3

2

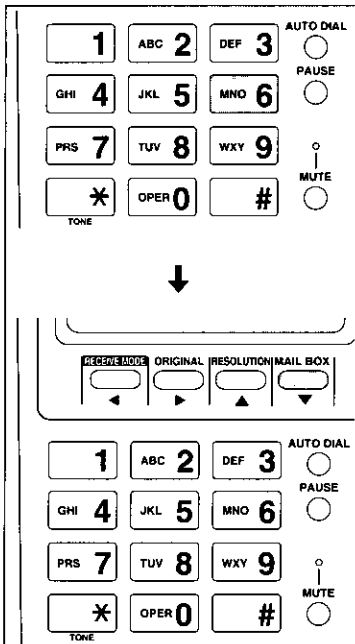

### ■ To access the desired index directly:

Press **6** to select "M".

The display shows the first name with the initial "M".

SELECT NAME <S06>  
=MAIN OFFICE

Station number —  
<AXX> ... Speed dialing  
<SXX> ... One-touch dialing

Then press ▼ repeatedly until "MARY" is displayed.

SELECT NAME <S07>  
=MARY

or

or

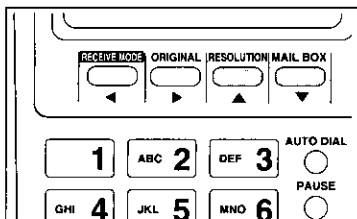

### ■ To look up the desired name in alphabetical order:

Press ▼ or ▲ repeatedly until the desired name is displayed.

The display shows the name in alphabetical order.

- Each press of ▼ shows the next name.
- Each press of ▲ shows the previous name.

(continued)

# 3

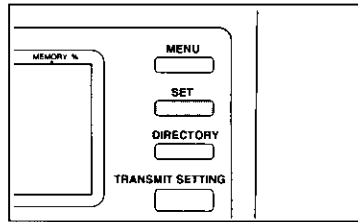

Press **SET** to start dialing.

```
AUG10  3:00PM 00 00
<MARY>
```

### *How to select an index:*

To select the desired index, use the dial keypad.

**Keypad:**    **Index:**

<b>1</b>	.....1
<b>GHI 4</b>	.....GHI4
<b>PRS 7</b>	.....PQRS7
<b>* <small>TONF</small></b>	.....(not assigned)

**Keypad:**    **Index:**

<b>ABC 2</b>	.....ABC2
<b>JKL 5</b>	.....JKL5
<b>TUV 8</b>	.....TUV8
<b>OPER 0</b>	.....0

**Keypad:**    **Index:**

<b>DEF 3</b>	.....DEF3
<b>MNO 6</b>	.....MNO6
<b>WXY 9</b>	.....WXYZ9
<b>#</b>	.....Others

# Transmitting Documents Using Automatic Dialer \_\_\_\_\_

You can transmit documents automatically by using one-touch dialing (including the BROADCAST keys) and speed dialing. Before using these features, make sure that the desired telephone numbers have been stored into memory. For storing phone numbers, see pages 81 to 88.

## HELPFUL HINT:

- If you lose your instructions while operating, press the HELP button. The unit will print information on how to operate.

## Using one-touch dialing

1

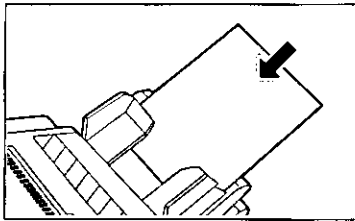

Insert the documents FACE DOWN.

2

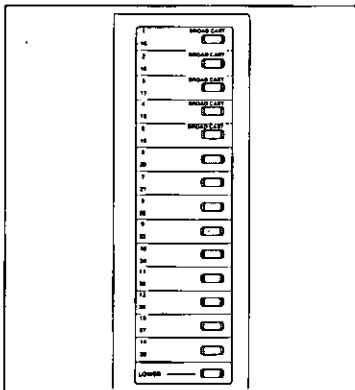

Press the desired direct call station key.

- When using the station numbers 15 to 28, press **LOWER** and then the direct call station key.

The display shows the station name or station number, and the unit dials and transmits the documents automatically.

```
DIALING <XMT>
TO: XXXXXXXXXX
```

## Interrupting transmission:

- Press the STOP/CLEAR button until a beep sounds. To eject the document, press the STOP/CLEAR button again.

## NOTES:

- If there is no answer or the line is busy, the unit will automatically redial the number. See item number 7 on page 229.
- To cancel redialing, press the STOP/CLEAR button.

3

## Using the broadcast keys

The documents will be scanned and stored into memory when using the BROADCAST key. After transmission, the stored documents will be erased automatically.

– Concerning the memory capacity for storing documents, see page 8.

1

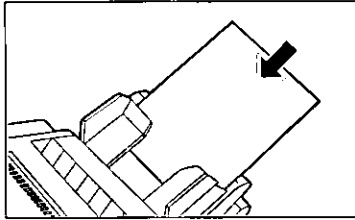

Insert the documents FACE DOWN.

2

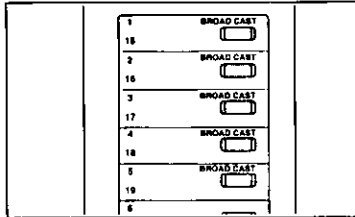

Press the desired **BROADCAST**.

The documents are fed into the unit and scanned into memory. And then the unit transmits the documents to each station, calling each number sequentially, one after another.

```
DIALING <MULTI XMT>
TO: XXXXXXXXX
```

– The amount of memory used is shown as a percentage on the display.

```
AUG10 3:00PM 00 XX
PAGES=XX
```

### Interrupting transmission:

1. Press **STOP/CLEAR** twice.

```
CANCEL MULTI
XMT? [1.YES 2.NO]
```

2. Press 1.

The transmission will be interrupted and the stored documents will be erased from memory.

### NOTES:

- Select the standard resolution when using the BROADCAST key. If you select the fine or halftone resolution, the number of documents that the unit can transmit will be decreased.
- A multitransmission report will be printed out after the transmission. This report will show the result. See page 114.
- If one of the stations is busy or does not answer, the station has been skipped, and the unit will automatically dial the next selected station. All skipped stations will be redialed after all other stations have been called. See item number 7 on page 229.

## Using speed dialing

1

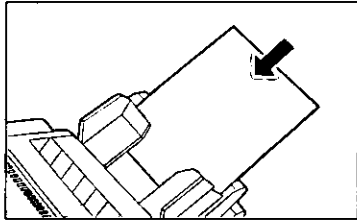

Insert the documents FACE DOWN.

2

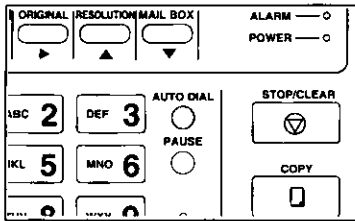

Press **AUTO DIAL**.

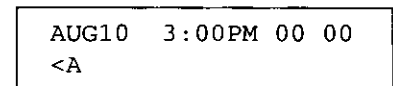

3

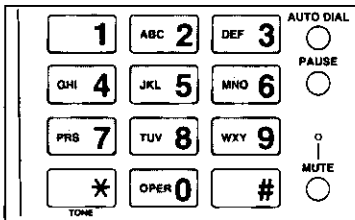

Enter the desired 2-digit number (00 to 99).

The display shows the station name or station number, and the unit dials and transmits the documents automatically.

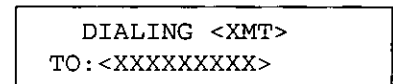

### Interrupting transmission:

- Press the STOP/CLEAR button until a beep sounds. To eject the document, press the STOP/CLEAR button again.

### NOTES:

- If there is no answer or the line is busy, the unit will automatically redial the number. See item number 7 on page 229.
- To cancel redialing, press the STOP/CLEAR button.

3

## Using the electronic telephone directory

You can transmit documents by selecting the desired name from the electronic telephone directory.

Make sure that the desired telephone numbers and their names have been stored into memory (see pages 81 to 88).

1

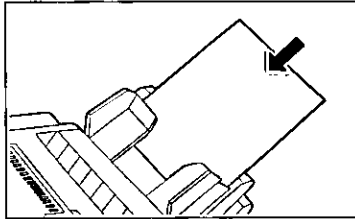

Insert the documents FACE DOWN.

2

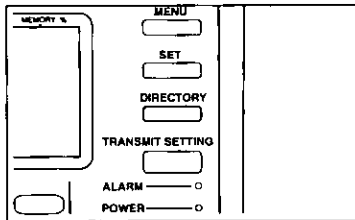

Press **DIRECTORY**.

SELECT INDEX  
A-Z, 0-9, #

3

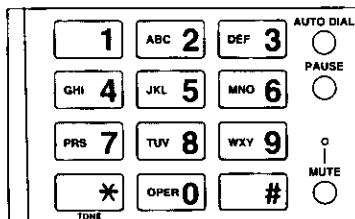

■ **To access the desired index directly:**  
Enter the desired index (see page 96).

The first name in the index is displayed.

SELECT NAME <XXX>  
=XXXXXXXXXX

or

or

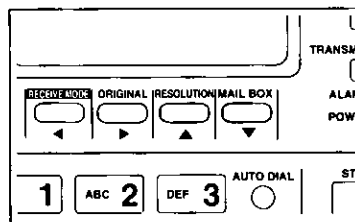

■ **To look up the desired name in alphabetical order:**

Press ▼ or ▲ until the desired name is shown.  
Skip step 4 and go to step 5 on the next page.

4

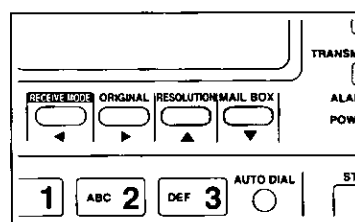

Press ▼ or ▲ until the desired name is shown.

– Use ▼ to advance the stored names, or ▲ to go back.

SELECT NAME <XXX>  
=XXXXXXXXXX

5

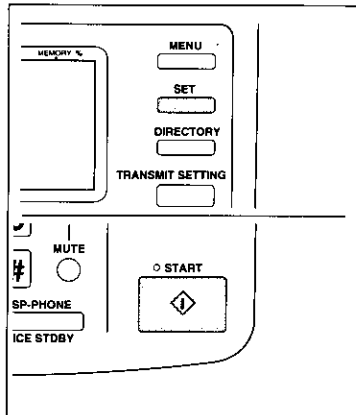

Press **SET** or **START**.

The unit dials and then transmits the documents automatically.

DIALING <XMT>  
TO: <XXXXXXXXXX>

3

**Interrupting transmission:**

- Press the STOP/CLEAR button until a beep sounds. To eject the document, press the STOP/CLEAR button again.

# Reserving Transmission while Receiving Documents

While the unit is receiving documents from one station, you can reserve transmission to another.

The unit will automatically scan and transmit documents after the fax reception.

## HELPFUL HINT:

- If you lose your instructions while programming, press the HELP button. The unit will print information on how to program.

1

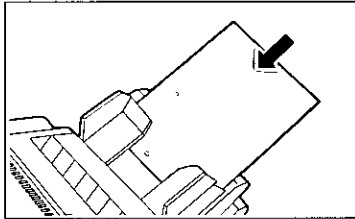

Insert the documents **FACE DOWN** during the fax reception.

```
RECEIVING      P 1
FROM:XXXXXXXX
```

2

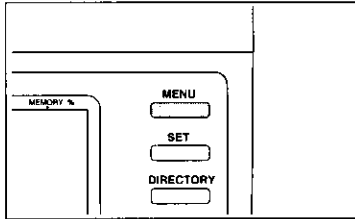

Press **MENU** until the following is shown.

```
XMT RESERVATION
ENTER PHONE NUMBER
```

3

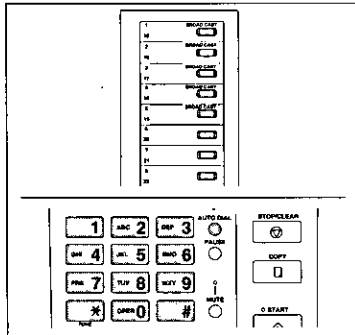

Enter the desired phone number by using the direct call station key, the speed dial station, or a full number.

**Example:** The direct call station 7 is dialed.

```
ENTER PHONE NUMBER
=<S07>
```

- If you have misdialed, press **STOP/CLEAR**, then enter the correct number.

4

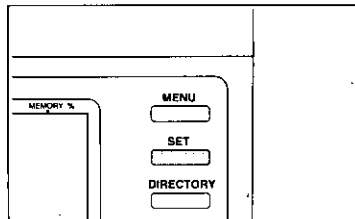

Press **SET** to set the reservation of transmission.

```
RECEIVING      P 1
DURING RESERVATION
```

- The unit will automatically scan and transmit documents after reception has finished.

## NOTES:

- You can use the electronic telephone directory (see page 95) when entering the phone number in step 3.
- To cancel the reservation, press the **STOP/CLEAR** button or remove the documents in the document feeder tray.



# Delayed Transmission

By using a built-in clock, the unit can transmit documents automatically at any time. This allows you the opportunity to take advantage of low-cost calling hours that are offered by some telephone companies. The delayed transmission can be set to take place at any time up to 24 hours in advance.

There are two ways to transmit documents with this feature. One option is that the documents to be transmitted are scanned and stored into memory, and the unit starts transmission at a specific time (delayed memory transmission). After transmission, the stored documents will be erased automatically. The other option is that the documents are left in the document feeder tray.

– Concerning the memory capacity for storing documents, see page 8.

## HELPFUL HINT:

– If you lose your instructions while programming, press the HELP button. The unit will print information on how to program.

1

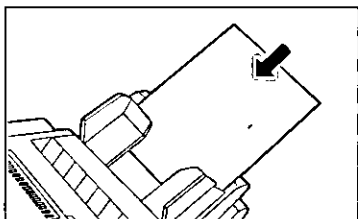

Insert the documents **FACE DOWN**.

2

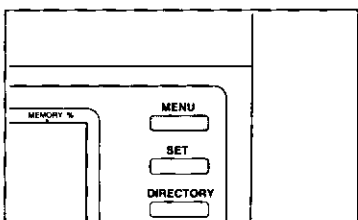

Press **MENU** until the following is shown.

```
DELAYED XMT
=OFF [1.ON 2.OFF]
```

3

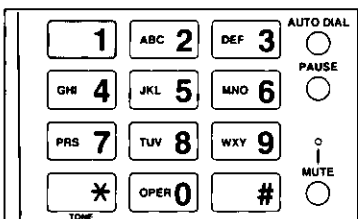

Press **1** to activate this feature.

```
DELAYED XMT
=ON [1.ON 2.OFF]
```

– If the delayed transmission is already set, the display will show the following:

```
OVERRIDE DELAYED
XMT ? [1.YES 2.NO]
```

Press **1** to override the previous setting.

Press **2** to interrupt the procedure.

4

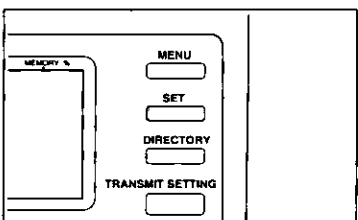

Press **SET** to store your selection into memory.

```
MEMORY DELAYED XMT
=ON [1.ON 2.OFF]
```

(continued)

5

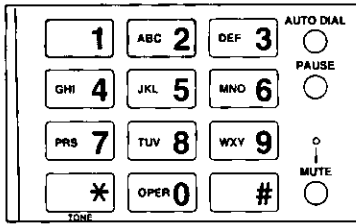

Enter the number of the selection you desire.

Setting selections:

- 1: ON (The delayed memory transmission will be activated.)
- 2: OFF (The delayed memory transmission will not be activated.)

6

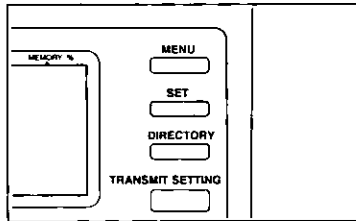

Press **SET** to store your selection into memory.

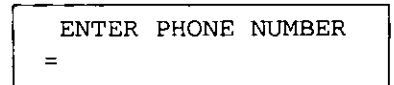

7

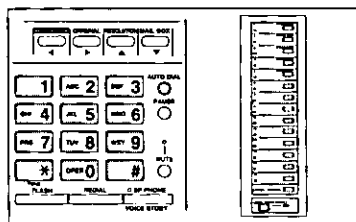

Enter the desired phone number by using the direct call station key, the speed dial station, or a full number.

**Example:** The direct call station 6 is dialed.

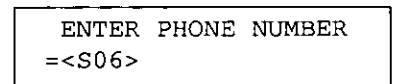

- If you have misdialed, press **STOP/CLEAR**, then enter the correct number.

8

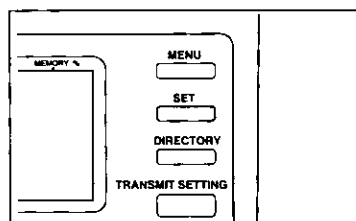

Press **SET** to store the number into memory.

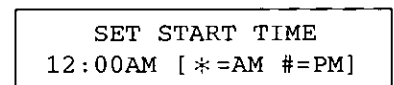

9



Enter the time of the start of transmission.

**Example:** If the starting time is 11:35PM, press **1135**, then press **#**.

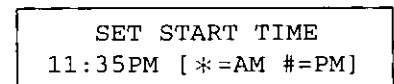

- To select AM mode, press **\***.
- To correct an error, use the cursor key ( ◀ or ▶ ) to move the cursor to the incorrect number, then make the correction.

# 10

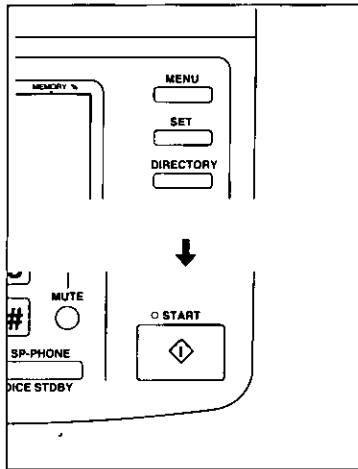

■ **When selecting the delayed memory transmission in step 5:**

1. Press **SET** to store the programming into memory.

PRESS  
START KEY

2. Press **START**.

The documents are fed into the unit and scanned into memory.

- The amount of memory used is shown as a percentage on the display.

AUG10 3:00PM 00 XX  
PAGES=XX

The delayed memory transmission will be set after scanning the documents.

AUG10 3:03PM 00 30  
XMT AT 11:35PM

or

or

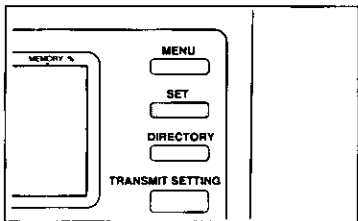

■ **When not selecting the delayed memory transmission in step 5:**

1. Press **SET** to store the programming into memory.

The delayed transmission will be set.

AUG10 3:00PM 00 00  
XMT AT 11:35AM

# 11

When a specified time has been reached, the unit will automatically start transmitting the documents.

- After the transmission, the delayed transmission feature is automatically turned off.

**NOTES:**

- You can receive, transmit, and copy documents while the delayed transmission is set. Remove documents for the delayed transmission from the document feeder tray, and transmit or copy documents. When you have finished, replace the removed documents.
- Select the standard resolution when selecting the delayed memory transmission. Otherwise the number of documents that the unit can transmit will be decreased.
- If there is no answer or the line is busy, the unit will automatically redial the number. See the item number 7, on page 229.
- To cancel redialing, press the STOP/CLEAR button.
- Only one delayed transmission can be programmed. If you program another delayed transmission, the previous one will be overridden.
- You can use the electronic telephone directory when entering the phone number in step 7 (see page 95).

*To cancel the delayed transmission:*

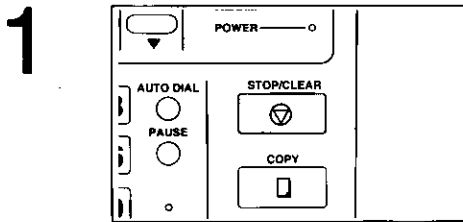

Press **STOP/CLEAR** after setting the delayed transmission.

CANCEL DELAYED  
XMT? [1.YES 2.NO]

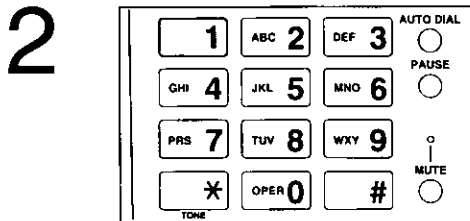

Press **1**.

The delayed transmission will be interrupted and the stored documents will be erased from memory.

- To continue the delayed transmission setting, press **2**.

# Polling

"Polling" means that you call another facsimile machine ("polled machine") to retrieve a document. The other party must be prepared for your call with a document loaded on the polled machine. This unit can both poll another facsimile machine and be polled. The machine initiating the call will incur any telephone charges.

## Polling another machine

The following instructions allow for the polling of another station. Make sure that no documents are in the feeder tray of your unit and that documents to be transmitted are loaded on the polled machine.

### HELPFUL HINT:

- If you lose your instructions while operating, press the HELP button. The unit will print information on how to operate.

1

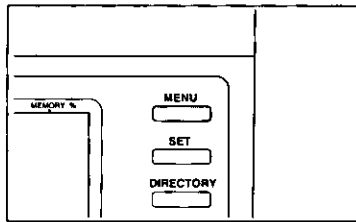

Press **MENU** until the following is shown.

POLLING  
ENTER PHONE NUMBER

2

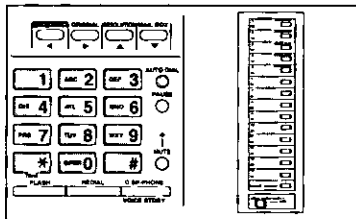

Enter the phone number of the unit you wish to poll by using the direct call station key, the speed dial station, or a full number.

**Example:** The direct call station 6 is dialed.

ENTER PHONE NUMBER  
=<S06>

- If you have misdialled, press **STOP/CLEAR**, then enter the correct number.

3

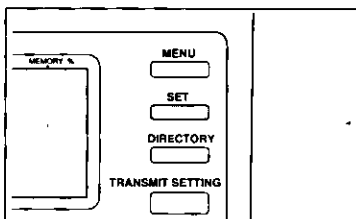

Press **SET** to store the phone number into memory.

PRESS  
START KEY

(continued)

3

4

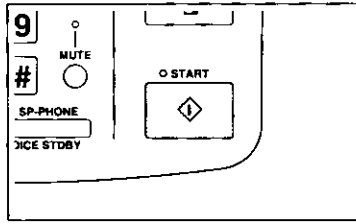

Press **START**.

The unit will automatically dial and receive documents from the polled machine.

DIALING <POLL>  
FROM: <S06>



POLLING P 1  
FROM: XXXXXX

– After receiving documents, the polling function is automatically turned off.

**NOTES:**

- If the polled station is busy or there is no answer, the unit will automatically redial the number. See item number 7 on page 229.
- To cancel redialing, press the STOP/CLEAR button.
- You can use the electronic telephone directory when entering the phone number in step 2 (see page 95).

**Being polled**

In order to let other units poll your unit, your unit must hold the documents in memory. Your unit will transmit the stored documents when the other party has polled your unit. The stored documents will be kept in memory even after the transmission. The polled function cannot activate in the *TEL* mode.

The following instructions allow your unit to prepare to transmit the document when being polled.

- Concerning the memory capacity for storing documents, see page 8.

**HELPFUL HINT:**

- If you lose your instructions while operating, press the HELP button. The unit will print information on how to operate.

1

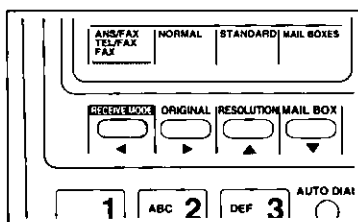

Set the receiving mode to the *ANS/FAX*, *TEL/FAX* or *FAX* mode.

2

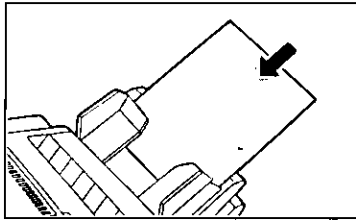

Insert the documents FACE DOWN.

3

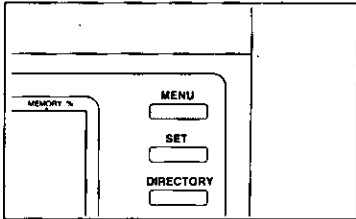

Press **MENU** until the following is shown.

```

POLLED ?
PRESS START KEY
  
```

4

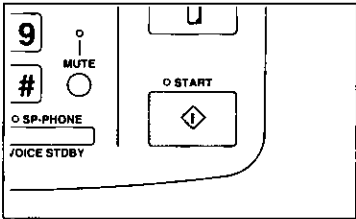

Press **START**.

The documents are fed into the unit and scanned into memory.

- The amount of memory used is shown as a percentage on the display.

```

AUG10, 3:00PM 00 05
PAGES=01
  
```

- The "polled" function will be set after scanning the documents, and polling can begin.

```

AUG10 3:00PM 00 05
POLLED ON
  
```

- If you have already set the polled mode, the display will show the following:

```

OVERRIDE POLLED
MODE? [1.YES 2.NO]
  
```

Press **1** to override the previous setting.  
 Press **2** to interrupt the procedure.

**NOTES:**

- You can receive, transmit, and copy documents while the polled mode is set.
- Select the standard resolution when setting the polled mode. Otherwise the number of documents that the unit can transmit will be decreased.

3

To cancel the polled mode:

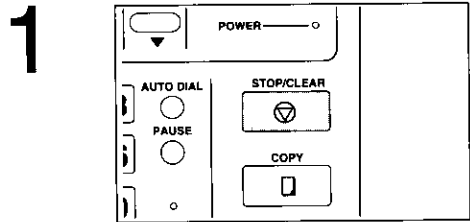

Press **STOP/CLEAR** after setting the polled mode.

CANCEL POLLED  
MODE? [1.YES 2.NO]

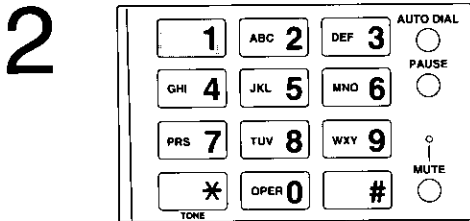

Press 1.

The polled mode will be interrupted and the stored documents will be erased from memory.

– To continue the polled mode, press 2.

## Programming the polling passcode

To prevent an unauthorized machine from retrieving a document of a confidential nature, program a unique passcode in your unit. If the passcodes between the polling machine and polled machine do not match, a transmission will not take place. The polling passcode is pre-programmed to "0000", which will not activate the passcode check.

### IMPORTANT:

– Polling using a passcode is effective between other compatible facsimile machines that have the same passcode. Concerning the compatibility, see page 8.

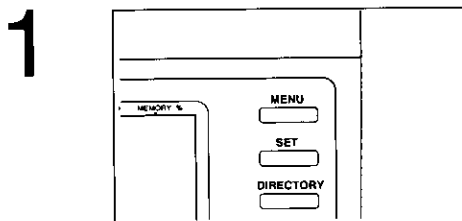

Press **MENU** until the following is shown.

PROG. [1.DATE 2.TEL  
3.SYSTEM 4.REPORT]

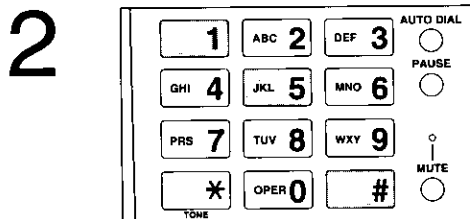

Press #, then press 15 to start programming.

POLLING PASSCODE  
=0000



# 3

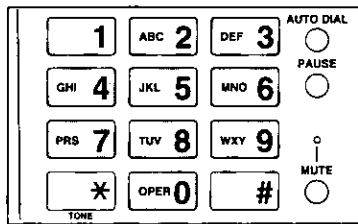

Enter the 4-digit polling passcode (choose from 0001 to 9999).

– To correct an error, use the cursor key ( ◀ or ▶ ) to move the cursor to the incorrect number, then make the correction.

# 4

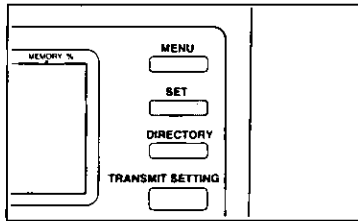

Press **SET** to store the program into memory.

PROG. [1.DATE 2.TEL  
3.SYSTEM 4.REPORT]

# 5

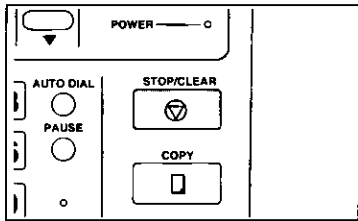

Press **STOP/CLEAR** to end the operation.

# 3

# Multistation Transmission

By using the built-in memory, you can transmit documents up to 128 stations at a time. This saves the trouble of sending the same documents to each station in succession. Multistation transmission is performed by using the direct call stations or speed dial stations.

Before using this feature, make sure that the desired phone numbers have been stored into the direct call stations or speed dial stations (see pages 81 to 88).

When using this feature, the documents will be scanned and stored into memory first. After transmission to all stations, the stored documents will be automatically erased.

– Concerning the memory capacity for storing documents, see page 8.

## HELPFUL HINT:

– If you lose your instructions while operating, press the HELP button. The unit will print information on how to operate.

1

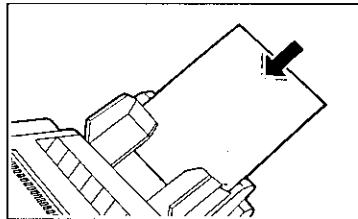

Insert the documents FACE DOWN.

2

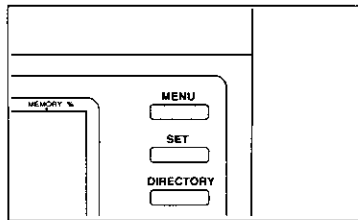

Press **MENU** until the following is shown.

```
MULTI XMT MODE
ENTER PHONE NUMBER
```

3

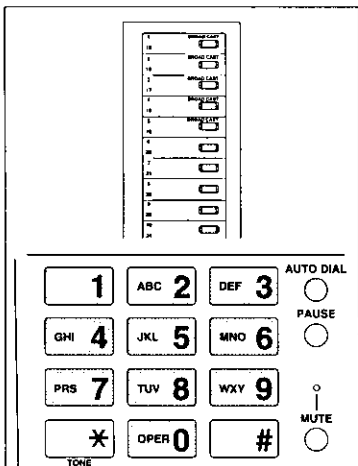

Enter the desired phone number by using the direct call station key or the speed dial station.

**Example:** The direct call station 8 is dialed.

```
ENTER PHONE NUMBER
=<S08>                [001]
```

– If you have misdialed, press **STOP/CLEAR**, then enter the correct number.

– When entering the phone number by using a full number, only one station will be acceptable.

4

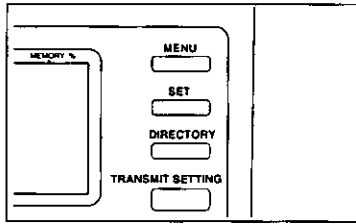

Press **SET** to store the number into memory.

```

ENTER PHONE NUMBER
=                [002]
  
```

- To enter other numbers, repeat steps 3 and 4 (up to 128 stations).

5

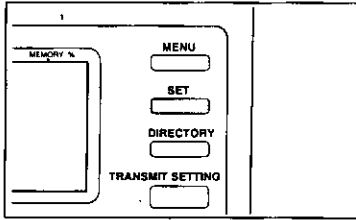

Press **SET** again after entering all the desired phone numbers.

```

PRESS
START KEY
  
```

6

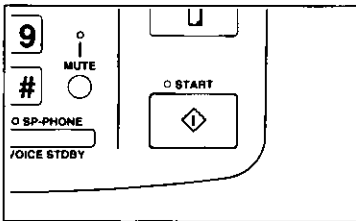

Press **START**.

The documents are fed into the unit and scanned into memory.

- The amount of memory used is shown as a percentage on the display.

```

AUG10  3:00PM 00 05
PAGES=01
  
```

- The unit then transmits the documents to each station, calling each number sequentially, one after another.

**NOTES:**

- Select the standard resolution when using a multistation transmission. Otherwise the number of documents that the unit can transmit will be decreased.
- If a station is busy or does not answer, the station has been skipped. The unit will automatically dial the next selected station. All skipped stations are redialed after all other stations have been called. See item number 7 on page 229. While waiting to redial, the following will be shown.

```

AUG10  3:00PM 00 05
MULTI XMT ON
  
```

- A multitransmission report will be printed out after all the transmissions have been completed. See page 114.
- You can use the electronic telephone directory when entering the phone number in step 3 (see page 95).

3

To cancel a multistation transmission:

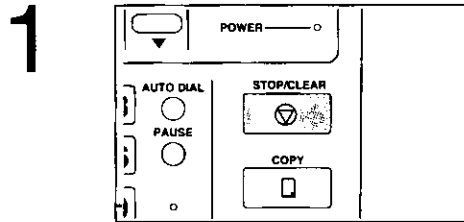

Press **STOP/CLEAR** twice after setting the multistation transmission.

```
CANCEL MULTI
XMT? [1.YES 2.NO]
```

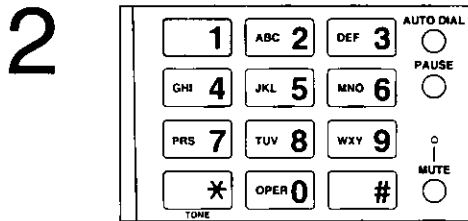

Press 1.

The multistation transmission will be interrupted and the stored documents will be erased from memory.

– To continue the transmission, press 2.

**NOTES:**

- A multitransmission report will be printed out. See below.
- If you press the STOP/CLEAR button while dialing or transmitting, only the displayed transaction will be interrupted.

**Multitransmission report**

After all the transmissions have been completed, the unit will automatically print the following report:

**Sample of the multitransmission report:**

```
***** MULTI TRANSMISSION REPORT *****
*
*                                     AUG. 10. 1994   3:36PM
*
* No.   OTHER FACSIMILE      START TIME   USAGE TIME  TX PAGES  RESULT      *CODE
* 001   MAIN OFFICE         AUG. 10  3:31PM  00'42     00        NO RESPONSE
* 002   MARY                 AUG. 10  3:33PM  00'41     00        NO RESPONSE
* 003   Quasar              AUG. 10  3:34PM  00'42     00        NO RESPONSE
* 004   Anthony             AUG. 10  3:35PM  00'41     00        NO RESPONSE
*
*                                     TOTAL          02'46     00
*
*                                     RESULT : NO RESPONSE
*                                     << POSSIBILITY OF REASON >>
*                                     1. RECEIVING FAX BUSY.
*                                     2. RECEIVING FAX OUT OF PAPER.
*                                     3. POWER FAILURE OR OTHERS.
*
*****
```

# Memory Transmission

The unit will be able to scan and store the documents into memory, and the unit will transmit the stored documents.

The stored documents will be automatically erased after transmission.

– Concerning the memory capacity for storing documents, see page 8.

## Setting the memory transmission

### HELPFUL HINT:

- If you lose your instructions while programming, press the HELP button. The unit will print information on how to program.

1

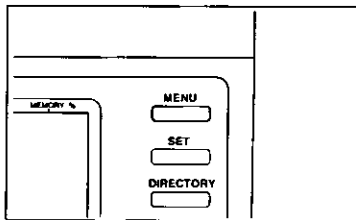

Press **MENU** until the following is shown.

PROG. [1.DATE 2.TEL  
3.SYSTEM 4.REPORT]

2

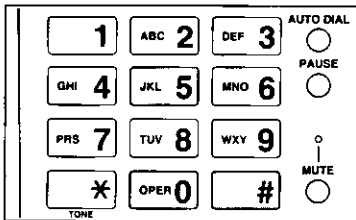

Press #, then press **05** to start programming.

MEMORY XMT  
=OFF [1.ON 2.OFF]

3

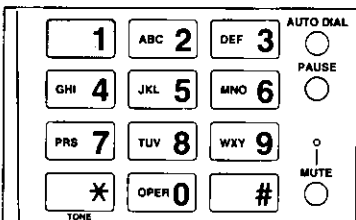

Press **1** to activate this feature.

MEMORY XMT  
=ON [1.ON 2.OFF]

– To de-activate this feature, press 2.

4

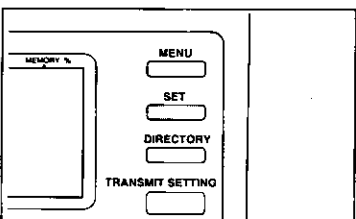

Press **SET** to store your selection into memory.

PROG. [1.DATE 2.TEL  
3.SYSTEM 4.REPORT]

5

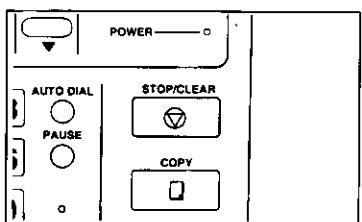

Press **STOP/CLEAR** to end the operation.

- The memory transmission function has been set.
- Go to page 116 to start transmission.

**NOTES:**

- Whenever you transmit the document by using the polled mode or multistation transmission, the memory transmission will be activated, regardless of whether it is set or not.
- Select the standard resolution when using the memory transmission. Otherwise the number of documents that can be stored into memory will be decreased.

## ***Transmitting the stored documents***

**1**

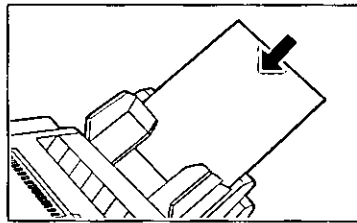

Insert the documents **FACE DOWN**.

**2**

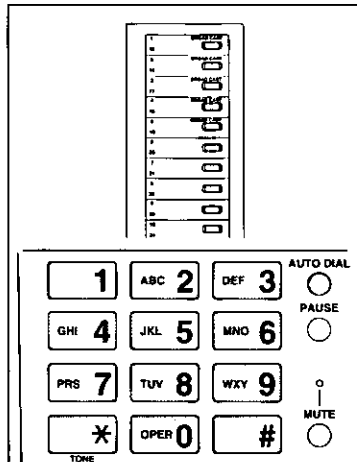

Enter the desired phone number by using the direct call station key, the speed dial station, or a full number.

- If you have misdialled, press **STOP/CLEAR**, then enter the correct number.
- Press **START** when entering a full number.

The documents are fed into the unit and scanned into memory.

After storing all pages, the unit transmits the documents.

- The amount of memory used is shown as a percentage on the display.

AUG10 3:00PM 00 05  
PAGES=01

**NOTES:**

- If there is no answer or the line is busy, the unit will automatically redial the number. See item number 7 on page 229.
- To cancel redialing, press the **STOP/CLEAR** button.
- You can use the electronic telephone directory when entering the phone number in step 2 (see page 95).

To cancel the memory transmission:

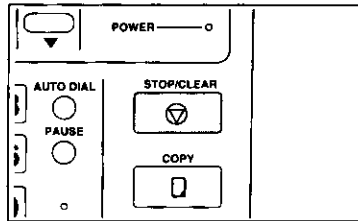

Press **STOP/CLEAR** while or after scanning documents.

The unit will stop the transmission, and the stored documents will be erased from memory.

```
AUG10 3:01PM 00 00
USER STOPPED
```

# Mail Box

The mail box feature is useful when you use this unit jointly with some persons and you wish your caller would send a fax-message directly to you. Your caller can send a fax-message in a mail box by specifying the mail box number whenever the unit is in the *ANS/FAX*, *TEL/FAX* or *FAX* mode, and only one who knows the passcode can retrieve it from the mail box.

This unit has such five personal mail boxes (mail box number 1 through 5) and you can program a passcode for each one of them.

In order to leave a fax-message in a mail box, each owner of the mail boxes must inform callers the mail box number in advance.

Moreover, you can retrieve a fax-message in your mail box from a remote facsimile unit. See page 122.

## Programming the mail box passcode

Each owner of the mail boxes must enter a passcode for their mail box to prevent retrieving from unauthorized persons when using this feature.

The mail box passcode is preprogrammed to "555" for every mail box. If you wish to change it, you can choose any 3-digit number from "111" to "999" except number including "0".

You should also use a number that is different from the remote code (see page 139) and the privacy ring ID number (see page 148).

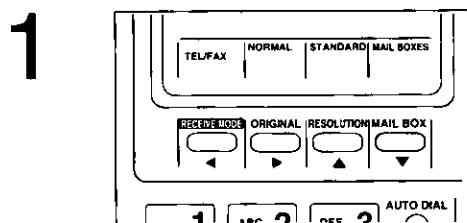

Press **MAIL BOX** until the following is shown.

CHANGE BOX PASSCODE  
BOX NO. = [1-5]

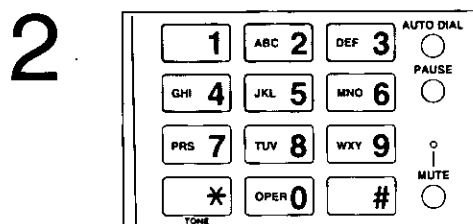

Enter the desired mail box number (1 to 5).

**Example:** The mail box number is 1.

CHANGE BOX PASSCODE  
BOX NO. =1 [1-5]

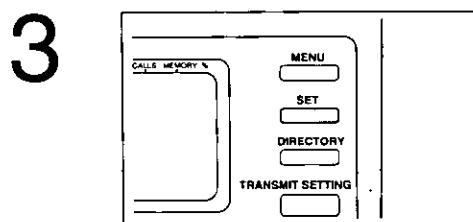

Press **SET**.



- When you program the passcode of the mail box for the first time:

MAIL BOX NO.<1>  
NEW PASSCODE=

- When you have programmed the passcode of the mail box before:

MAIL BOX NO.<1>  
OLD PASSCODE=

1. Enter the current mail box passcode of 3 digits.
  - If you enter a different number from the current passcode, 3 beeps sound. Enter the correct number.
2. Press **SET**.

MAIL BOX NO.<1>  
NEW PASSCODE=

4

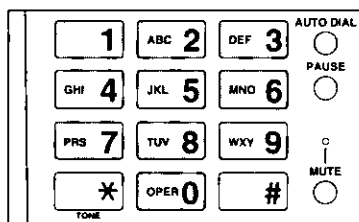

Enter the desired new passcode of 3-digit number.

**Example:** The mail box passcode is 789.

MAIL BOX NO.<1>  
NEW PASSCODE=789

5

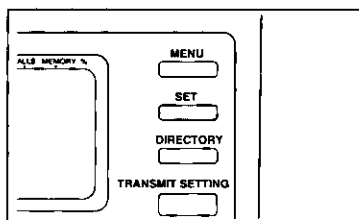

Press **SET** to store the program into memory.

**NOTES:**

- To correct an error while programming, use the cursor key ( ◀ or ▶ ) to move the cursor to the incorrect number, then make the correction.
- To cancel the programming halfway, press the STOP/CLEAR button.
- If you forget your passcode, consult your service center. See page 240.
- After programming, memorize your passcodes by filling in the following table.

MAIL BOX NO.	MAIL BOX PASSCODE	USER
1		
2		
3		
4		
5		

3

## Transmitting documents to your mail box

Set the receiving mode to the *ANS/FAX*, *TEL/FAX* or *FAX* mode to receive documents in your mail box.

1



Call your unit with a **touch tone telephone-facsimile**.

2

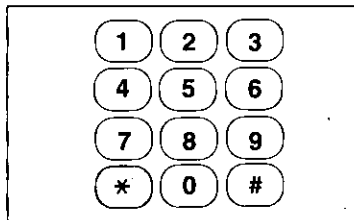

Press **\***, then enter the desired mail box number (1 to 5) while the greeting message is playing or incoming message recording mode, or at a silent interval between the fax tones.

3

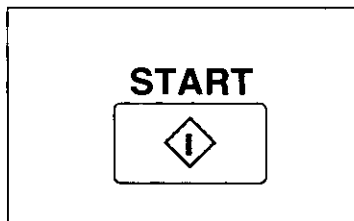

Start transmission upon hearing the fax tone by pressing the start or transmit button.

The unit receives the document storing it into the specified mail box.

While reception, the display shows the following message.

RECEIVING MAIL	P1
FROM: XXXXX	

The number of the mail box indicator lights.

## Retrieving documents in a mail box

The mail box indicator tells the owners which mail box has a fax-message by lighting its mail box number.

### NOTE:

- When the mail box passcode is the pre-selected number "555", anyone can retrieve the fax-message from the mail box without entering the passcode.

1

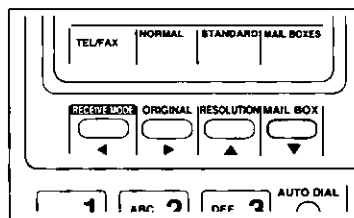

Press **MAIL BOX** until the following is shown.

PRINT OUT MAIL	
BOX NO. =	[1-5]

2

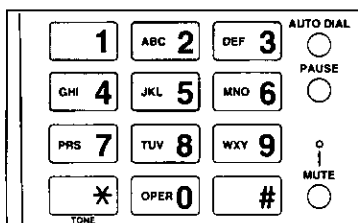

Enter the number (1 to 5) of the mail box from which you want to retrieve the documents.

**Example:** The mail box number is 1.

```
PRINT OUT MAIL
BOX NO.=1      [1-5]
```

3

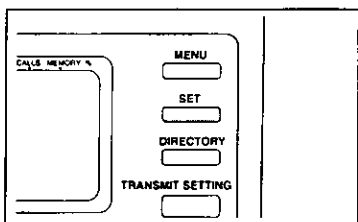

Press **SET**.

4

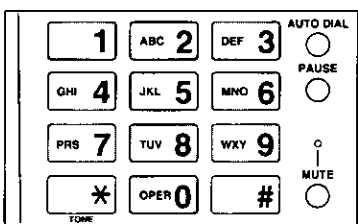

■ When the mail box passcode is other than the pre-selected number "555":

```
MAIL BOX NO.<1>
PASSCODE=
```

1. Enter the mail box passcode of 3-digit.
  - If you enter a different number from the correct passcode, 3 beeps sound. Try again from step 1 and enter the correct number.
2. Press **SET**.

The unit starts to print all documents stored into the specified mail box.

```
MAIL BOX NO.<1>
PRINTING
```

■ When the mail box passcode is the preselected number "555":

The unit starts to print all documents stored into the specified mail box.

```
MAIL BOX NO.<1>
PRINTING
```

- After printing, the mail box number in the mail box indicator will go out.

**NOTES:**

- To cancel the operation halfway, press the STOP/CLEAR button.
- To stop printing, press the STOP/CLEAR button. The printing is interrupted from the next page.

## Retrieving documents in a mail box from remote location

The following operation allows your unit to transmit fax-messages stored into your mail box to another remote facsimile.

Set the receiving mode of your unit to the *ANS/FAX*, *TEL/FAX* or *FAX* mode to activate this feature.

1



Call your unit with a **touch tone telephone-facsimile**.

2

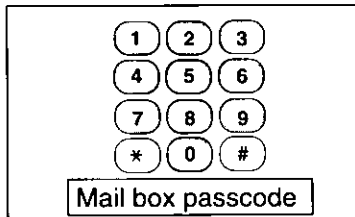

Dial your mail box passcode while the greeting message is playing or incoming message recording mode, or at a silent interval between fax tones.

3

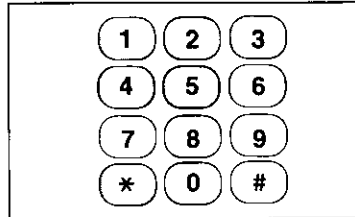

Press **\***, then enter your mail box number (1 to 5).

A slow beep sounds.

4

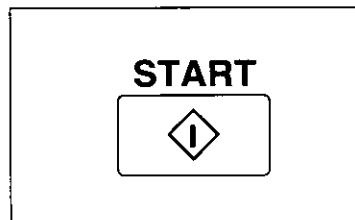

Start reception upon hearing the beep by pressing the start or transmit button.

Your unit transmits the documents stored into the specified mail box to the calling machine. While transmission, the display shows the following message.

SENDING MAIL	P1
TO: XXXXX	

– After transmitting, the mail box number in the mail box indicator will go out.

# Network Communication

---

The network communication feature eliminates fax transmissions to unauthorized parties, and helps to prevent reception from unauthorized stations. This feature is effective in preventing "junk mail" faxes.

When the network communication feature is used, the identical network passcode of 4 digits must be programmed on both sides of the line. The unit checks the passcode before transmitting or receiving a document.

The unit provides two types of passcode check modes as below.

■ **Transmission passcode check mode:**

Activate this mode to restrict document transmission. If the passcode sent from the other machines does not match with the one programmed in your unit, transmission will not take place.

■ **Reception passcode check mode:**

Activate this mode to restrict document reception. If the passcode sent from the other machines does not match with the one programmed in your unit, reception will not take place.

**IMPORTANT:**

- These features are effective between compatible facsimile machines that have the same passcode. Concerning the compatibility, see page 8.

**NOTE:**

- The passcode for the polling feature is not related to this network communication feature. They are independent features.

## Using the network passcode

Before communication begins, check that your passcode and the other station's passcode are identical. See page 125 to program the passcode.

■ **To transmit a document to a designated station only:**

Set the transmission passcode check mode to on (see page 126).

Functions	Display indications	Your unit	Other compatible machine
Transmission passcode check mode	TX PASSCODE CHECK	ON	ON/OFF
Reception passcode check mode	RX PASSCODE CHECK	OFF	ON/OFF

Your unit transmits a document only when the correct passcode has been received.

■ **To receive a document from a designated station only:**

Set the reception passcode check mode to on (see page 127).

Functions	Display indications	Your unit	Other compatible machine
Transmission passcode check mode	TX PASSCODE CHECK	OFF	ON/OFF
Reception passcode check mode	RX PASSCODE CHECK	ON	ON/OFF

Your unit receives a document only when the correct passcode has been received.

■ **To transmit a document to, and receive a document from, a designated station:**

Set both the transmission and reception passcode check modes to on (see pages 126 and 127).

Functions	Display indications	Your unit	Other compatible machine
Transmission passcode check mode	TX PASSCODE CHECK	ON	ON/OFF
Reception passcode check mode	RX PASSCODE CHECK	ON	ON/OFF

Your unit transmits and receives a document only when the correct passcode has been received.

■ **To have facsimile communications within a designated group of people:**

All the people in the group must set both the transmission and reception passcode check modes to on (see pages 126 and 127).

Functions	Display indications	Your unit	Other compatible machine
Transmission passcode check mode	TX PASSCODE CHECK	ON	ON
Reception passcode check mode	RX PASSCODE CHECK	ON	ON

Only units that share identical passcodes can transmit and receive documents among each other.

## Programming the network passcode

To activate this feature, the identical network passcode must be pre-programmed, both on your unit and on the other compatible machine(s).  
The network passcode should be set any 4-digit number except "0000".

### IMPORTANT:

– The network passcode is pre-programmed to "0000", which will not activate the network communication.

1

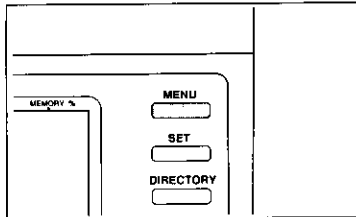

Press **MENU** until the following is shown.

PROG. [1.DATE 2.TEL  
3.SYSTEM 4.REPORT]

2

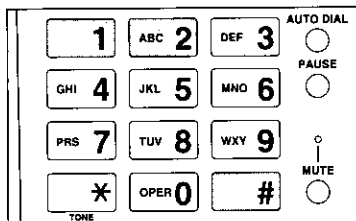

Press #, then press 12 to start programming.

NETWORK PASSCODE  
=0000

3

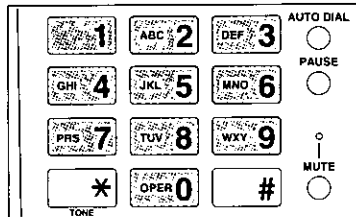

Enter the desired 4-digit passcode (choose 0001 to 9999).

– To correct an error, use the cursor key (◀ or ▶) to move the cursor to the incorrect number, then make the correction.

4

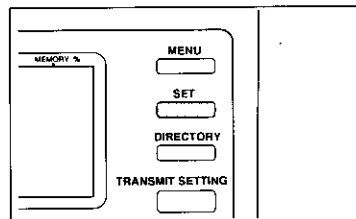

Press **SET** to store the program into memory.

PROG. [1.DATE 2.TEL  
3.SYSTEM 4.REPORT]

5

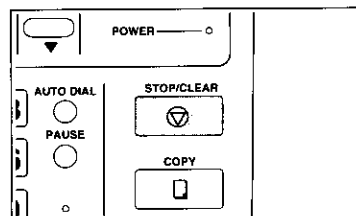

Press **STOP/CLEAR** to end the operation.

3

## Turning on the transmission passcode check mode

1

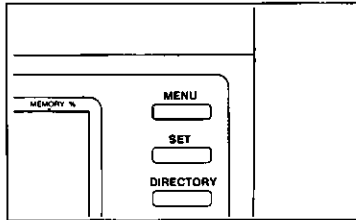

Press **MENU** until the following is shown.

PROG. [1.DATE 2.TEL  
3.SYSTEM 4.REPORT]

2

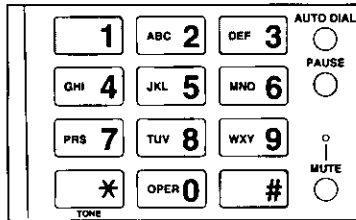

Press #, then press **13** to start programming.

TX PASSCODE CHECK  
=OFF [1.ON 2.OFF]

3

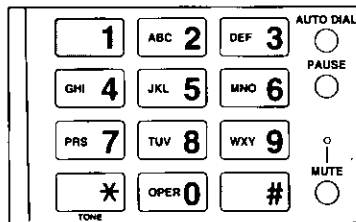

Press **1** to activate this feature.

TX PASSCODE CHECK  
=ON [1.ON 2.OFF]

– To turn off the transmission passcode check mode, press **2**.

4

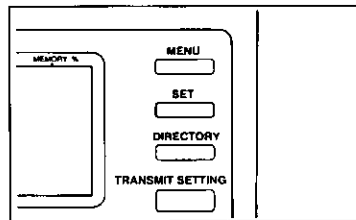

Press **SET** to store your selection into memory.

PROG. [1.DATE 2.TEL  
3.SYSTEM 4.REPORT]

5

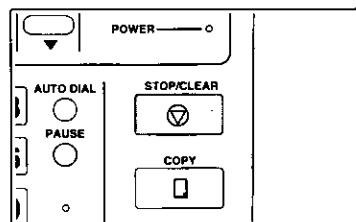

Press **STOP/CLEAR** to end the operation.



## Turning on the reception passcode check mode

1

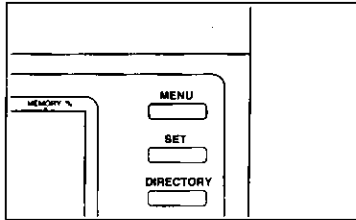

Press **MENU** until the following is shown.

PROG. [1.DATE 2.TEL  
3.SYSTEM 4.REPORT]

2

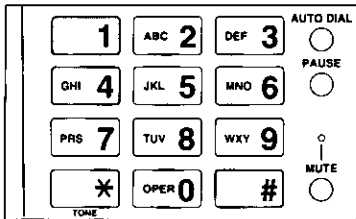

Press #, then press **14** to start programming.

RX PASSCODE CHECK  
=OFF [1.ON 2.OFF]

3

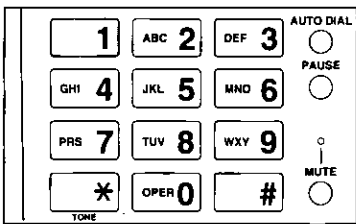

Press **1** to activate this feature.

RX PASSCODE CHECK  
=ON [1.ON 2.OFF]

– To turn off the reception passcode check mode, press **2**.

4

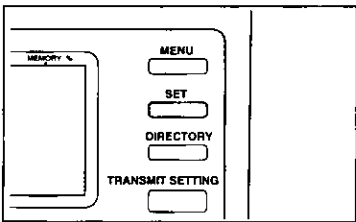

Press **SET** to store your selection into memory.

PROG. [1.DATE 2.TEL  
3.SYSTEM 4.REPORT]

5

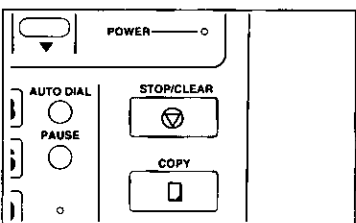

Press **STOP/CLEAR** to end the operation.

3

# Forwarding Received Documents

Once you turn this feature on, your unit will store the received documents into memory, and transmit them automatically to another specified facsimile machine successively. After forwarding, the documents stored into memory will be erased. If the unit is unable to forward the documents, they will remain in memory, and they can be manually retrieved.

– Concerning the memory capacity for storing documents, see page 8.

## IMPORTANT:

- The fax forwarding feature can be turned on when the receiving mode is set to the *ANS/FAX*, *TEL/FAX* or *FAX* mode.
- Documents received into the mail box are not forwarded.

1

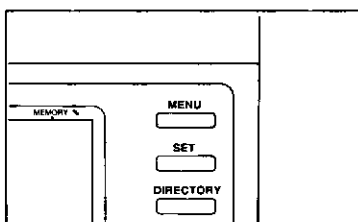

Press **MENU** until the following is shown.

PROG. [1.DATE 2.TEL  
3.SYSTEM 4.REPORT]

2

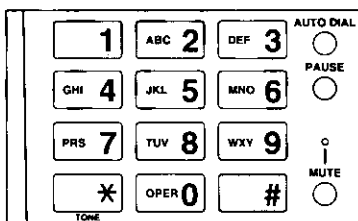

Press #, then press **21** to start programming.

FAX FORWARDING  
=OFF [1.ON 2.OFF]

3

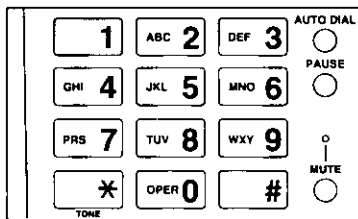

Press **1** to activate this feature.

FAX FORWARDING  
=ON [1.ON 2.OFF]

– To turn off the forwarding feature, press **2**.

4

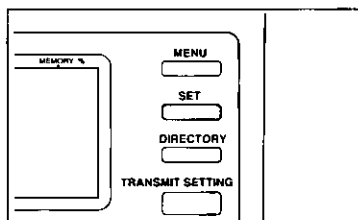

Press **SET** to store your selection into memory.

FORWARDING PHONE #  
=

– If the receiving mode is set to the *TEL* mode, the following message will be displayed:

CHANGE  
RECEIVE MODE

Press **RECEIVE MODE** to set to the *ANS/FAX* mode.

5

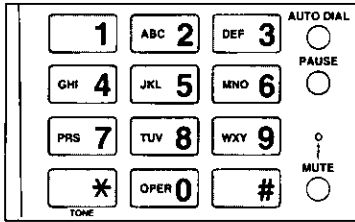

Enter the phone number of the receiving unit.

**Example:** The forwarding phone number is 9876543.

FORWARDING PHONE # =9876543
--------------------------------

- The phone number can be entered up to 30 digits in length.
- You can use the automatic dialer.

6

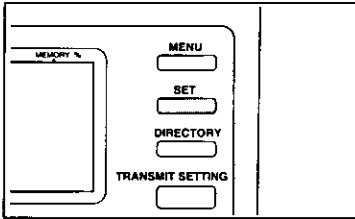

Press **SET** to store the program into memory.

PROG. [1.DATE 2.TEL 3.SYSTEM 4.REPORT]
---

7

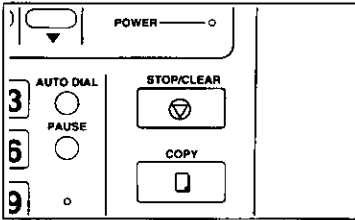

Press **STOP/CLEAR** to end the operation.

When the forwarding feature is set, the display shows:

AUG10 3:00PM 00 00 FAX FORWARDING ON
---

**NOTES:**

- To cancel the programming halfway, press the MENU button.
- This feature can be turned on or off from a remote location. See page 131.
- If there is no answer or the line is busy, the unit will automatically redial the forwarding number. See item number 7 on page 229.
- When you change the receiving mode while the forwarding feature is on, the display may show the following message:

CANCEL FORWARDING ? [1.YES 2.NO]
-------------------------------------

Press 1 to cancel the forwarding feature and to change the receiving mode.

Press 2 to continue the forwarding feature.

- If memory becomes full while receiving, the unit will stop receiving documents. And then, the unit will start forwarding the stored documents. If this occurs, the message indicating that all of the pages cannot be forwarded will be printed at the top of the forwarded last page.

## ***Fax forwarding report***

After forwarding documents, the unit automatically prints the following report:

**Sample of the fax forwarding report:**

```
***** FAX FORWARDING REPORT *****
*
*                                     AUG. 10. 1994   4:03PM
*
*  - RECEIVED BY -      START TIME   RX PAGES   RESULT
*  0924759269          AUG. 10   4:02PM       01        OK
*
*  - TRANSFERED TO -   START TIME   TX PAGES   RESULT
*  092 477 1237        AUG. 10   4:03PM       01        OK
*
*
*
*
*
*
*
*
*
*
*****
```

## Retrieving mis-forwarded documents

If the documents cannot be forwarded, the display will show the following message (the missed documents will remain in memory):

```
AUG10  3:42PM 00 05
CHECK FAX FORWARDING
```

To retrieve them, proceed as follows:

1

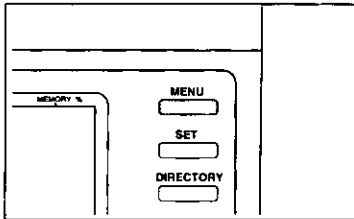

Press **MENU** until the following is shown.

```
FAX FORWARDING
PRESS SET TO PRINT
```

2

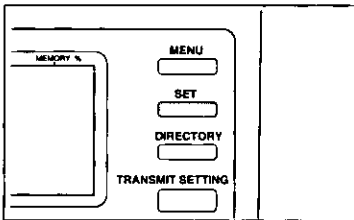

Press **SET** to print the documents.

The unit starts printing.

```
FAX FORWARDING
PRINTING
```

3

## Turning on or off the forwarding feature from a remote location

The following operation activates or de-activates the forwarding feature from a remote location.

### IMPORTANT:

- Use a touch-tone telephone with tone dialing for this operation.
- This feature is available in the *ANS/FAX*, *TEL/FAX* or *FAX* mode.

1



Call your unit.

2

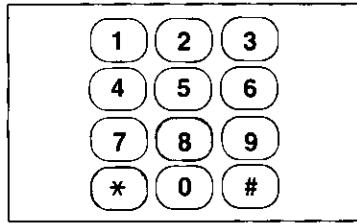

or

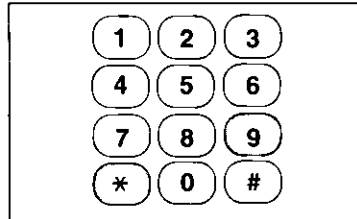

3

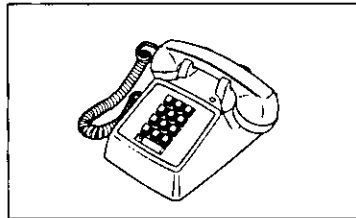

■ **When turning on the forwarding feature:**

Press \* and 8 while the greeting message is playing, incoming message recording mode, or at a silent interval between fax tones.

After a beep, the forwarding feature is turned on.

or

■ **When turning off the forwarding feature:**

Press \* and 9 while the greeting message is playing, incoming message recording mode, or at a silent interval between fax tones.

After two beeps, the forwarding feature is turned off.

Hang up.

**NOTES:**

- If a continuation of short beeps sounds, you will fail in the remote operation. Press the button firmly within 30 seconds.
- If a forwarding phone number is not programmed in the unit, this feature cannot be used.
- While the remote operation, your unit will show the following message:

DURING  
REMOTE SETTING

# Using the TRANSMIT SETTING Button

The TRANSMIT SETTING button allows for the printing of the total page number and the special message at the top of all transmitted pages, and for the setting of the overseas transmission mode.

## Total page number and the special message

The total page number and the special message that are pre-programmed in your unit can be printed at the top of all transmitted pages.

You can choose the desired message among the following:

- A: CONFIDENTIAL
- B: URGENT REPLY REQUEST
- C: URGENT PLEASE READ
- D: personal message (see page 136)

### Sample page transmitted from your unit:

e.g. The message "CONFIDENTIAL" is selected.

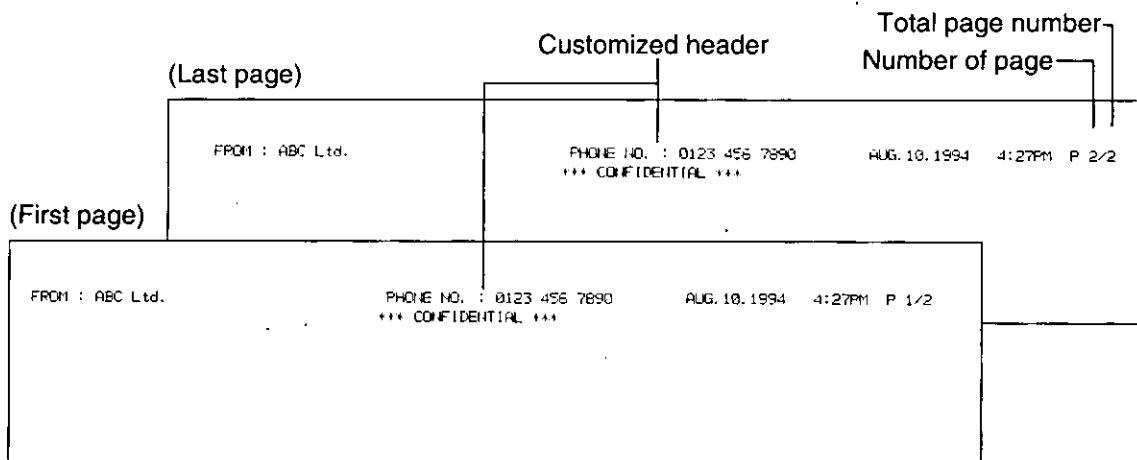

### NOTE:

- When transmitting the documents by using the following functions, the unit will automatically print the total page number, regardless of the setting:
  - Delayed memory transmission (see page 103)
  - Polled mode (see page 108)
  - Multistation transmission (see page 112)
  - Memory transmission (see page 115)

## Overseas transmission mode

If there is difficulty in transmitting documents overseas, use the overseas transmission mode. To set this mode, follow the steps below:

### NOTES:

- When the overseas transmission mode is set, the time required to make the transmission will be longer than normal.
- The overseas transmission mode cannot be used in combination with delayed, multi, or memory transmission.
- If a transmission error still occurs in the overseas transmission mode, lower the transmission speed (see page 184), and try again. Or, when dialing the phone number, add two pauses at the end of the number by pressing the PAUSE button (see page 153).

## Transmitting documents with the TRANSMIT SETTING button

To set the total page number, the customized header, or the overseas transmission mode, follow the steps below:

### HELPFUL HINT:

- If you lose your instructions while operating, press the HELP button. The unit will print information on how to operate.

1

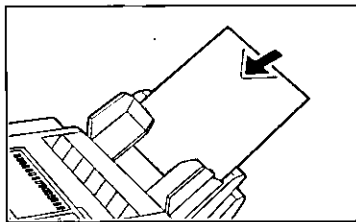

Insert the documents FACE DOWN.

2

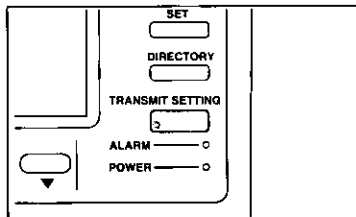

Press **TRANSMIT SETTING** until the following is shown.

SET NUMBER OF PAGES  
TOTAL=0

3

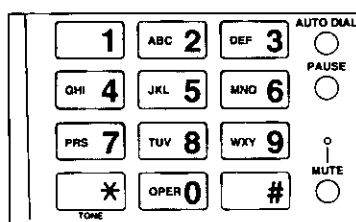

Enter the total number of pages (1 to 99).

- If the total page number is unnecessary, press 0 or skip this step and go to step 4.



4

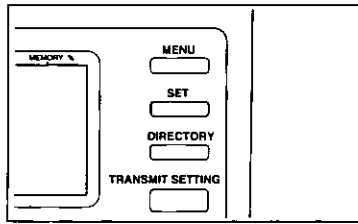

Press **SET** to store the number into memory.

MESSG. OUT =OFF [1.A  
2.B 3.C 4.D 5.OFF]

5

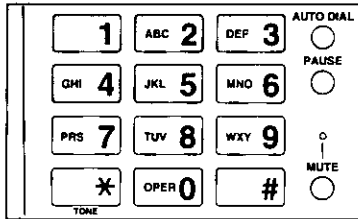

Enter the number of the selection you desire.

Setting selections:

- 1: A (CONFIDENTIAL)
- 2: B (URGENT REPLY REQUEST)
- 3: C (URGENT PLEASE READ)
- 4: D (a personal message ) (see page 136)
- 5: OFF (a message will not print.) (pre-selected setting)

- If the special message is unnecessary, skip this step and go to step 6.

6

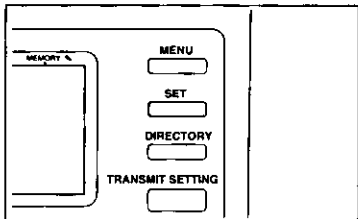

Press **SET** to store your selection into memory.

OVERSEAS MODE  
=OFF [1.ON 2.OFF]

7

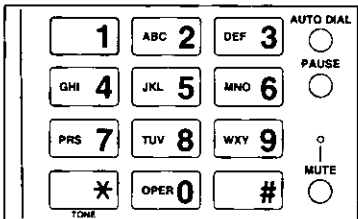

Press **1** to activate the overseas transmission mode.

- To de-activate the overseas transmission mode, press **2**.
- If the overseas transmission mode is unnecessary, skip this step and go to step 8.

8

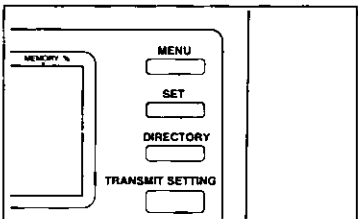

Press **SET** to store your selection into memory.

AUG10 3:00PM 00 00

9

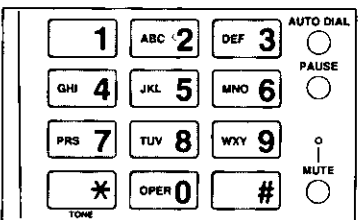

Enter the desired phone number.

- You can use the automatic dialer.

(continued)

10

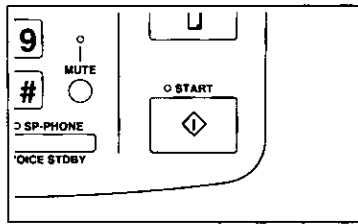

Press **START**.

The unit dials and then transmits documents automatically.

**NOTE:**

– These features will automatically be turned off after each transmission has been completed.

**Programming a personal message**

A programmed personal message can be printed at the top of all transmitted pages. This message will be printed only when requested through transmission with the TRANSMIT SETTING button (see page 134).

**Example:** A personal message is “WELCOME to Panasonic”.

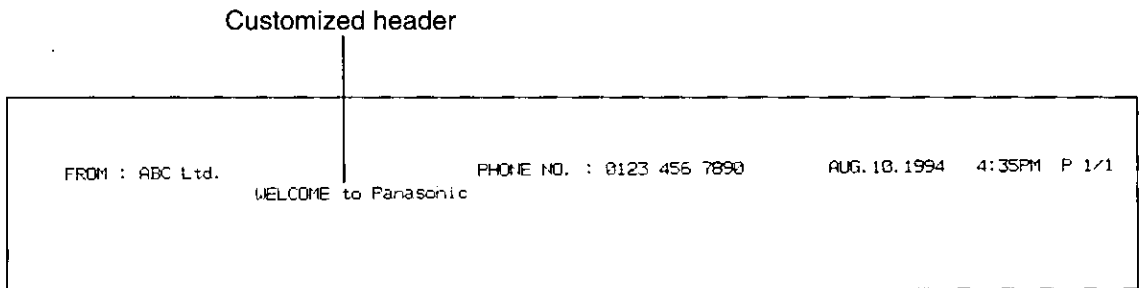

To program a personal message, proceed as follows:

1

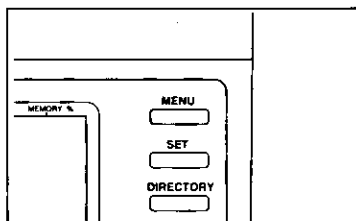

Press **MENU** until the following is shown.

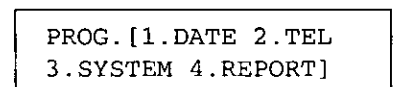

2



Press **#**, then press **18** to start programming.

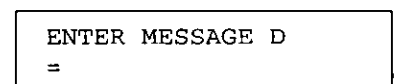

3

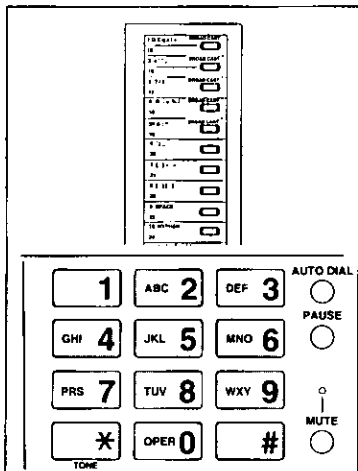

Enter the message up to 64 characters you wish to print by using the character keys and dial key pad.

– For further details, see page 47.

ENTER MESSAGE D  
=WELCOME to Pana

4

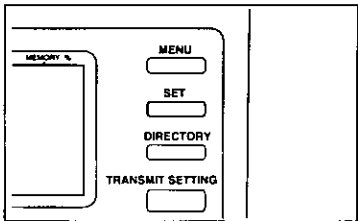

Press **SET** to store the program into memory.

PROG. [1.DATE 2.TEL  
3.SYSTEM 4.REPORT]

5

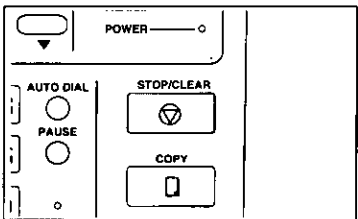

Press **STOP/CLEAR** to end the operation.

– To transmit a document with the personal message that you programmed, use **TRANSMIT SETTING** (see page 134) and select "4" (D: a personal message) in step 5.

3

# Remote Operations of the Answering Device \_\_\_\_\_

While you are out, you can operate the answering device of your unit from a remote location.

**IMPORTANT:**

- These features can only be used from touch tone telephone.
- These features are available when your unit is in the *ANS/FAX* mode.

**NOTES:**

- When using the remote operations, you must enter the unique remote code. The remote code will prevent unauthorized persons from accessing your unit.
- The remote code is preprogrammed to "111". If you wish to change the code, see page 139.

## Summary of remote operations

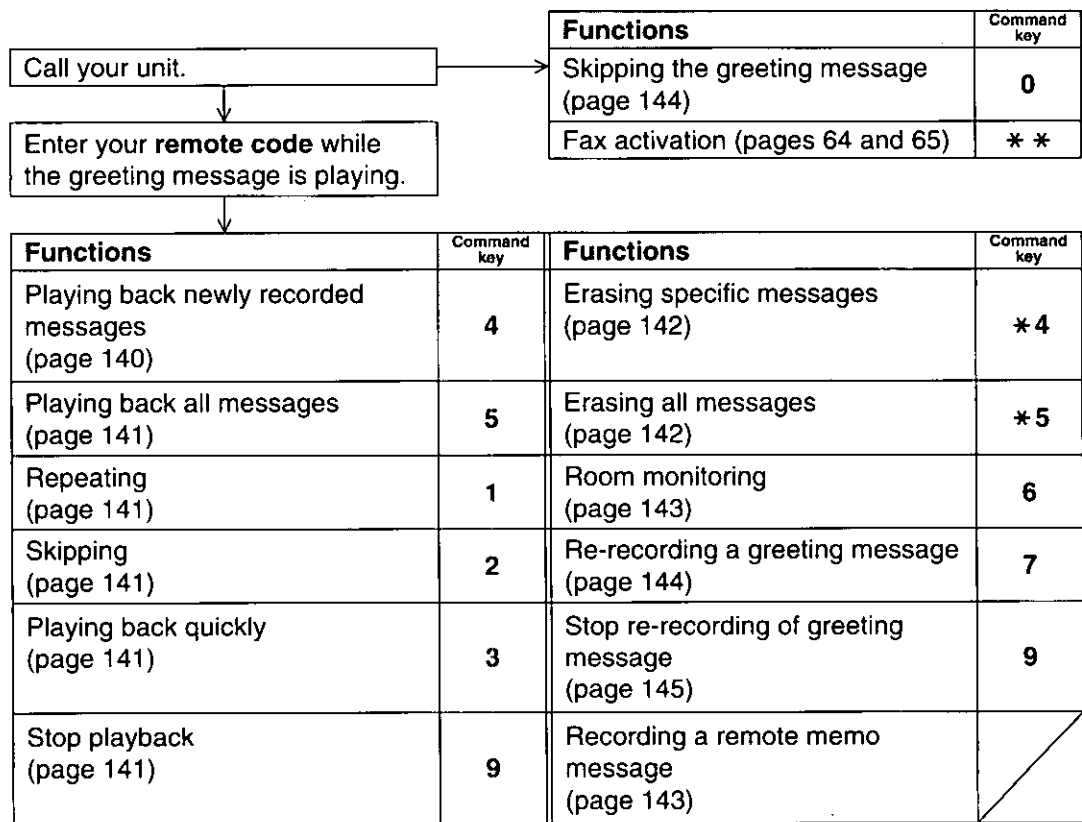

**NOTES:**

- Dial the command key within 4 seconds after the long beep followed the greeting message. Or the unit starts the playback of all messages recorded.
- For your convenience, a quick reference card for remote operations is provided (see pages 233 and 234, or a separated card).

## Programming the remote code

If you wish to change the remote code, you can choose any 3-digit number from "111" to "999" except numbers including "0".

For proper operation, make sure that the remote code is different from your privacy ring ID number (see page 148) and the mail box passcode (see page 118).

### HELPFUL HINT:

- If you lose your instructions while programming, press the HELP button. The unit will print information on how to set.

1

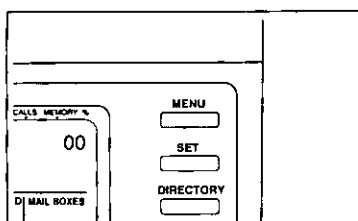

Press **MENU** until the following is shown.

PROG. [1.DATE 2.TEL  
3.SYSTEM 4.REPORT]

2

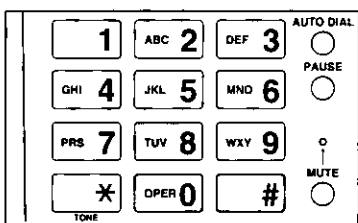

Press #, then press **08** to start programming.

ENTER YOUR REMOTE  
ANS ID=111

3

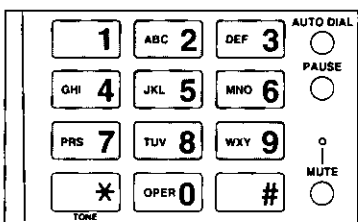

Enter the desired number of 3 digits.

- You can choose among numbers "111" through "999" not including "0".

**Example:** The remote code is 456.

ENTER YOUR REMOTE  
ANS ID=456

- To correct an error, use the cursor key ( ◀ or ▶ ) to move the cursor to the incorrect number then make the correction.

4

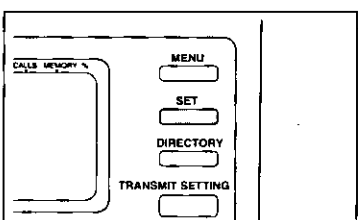

Press **SET** to store your selection into memory.

PROG. [1.DATE 2.TEL  
3.SYSTEM 4.REPORT]

3

# 5

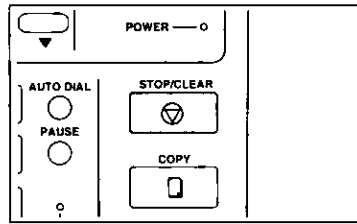

Press **STOP/CLEAR** to end the operation.

**NOTE:**

- We recommend that you do not use "7", since this number is used as the greeting message re-recording command for remote operations.

## ***Playing back newly recorded messages***

It is possible to skip over the recorded messages you have already heard and to play back only new messages.

# 1

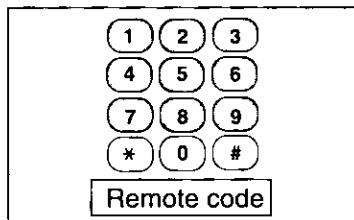

Call your unit and dial your remote code while the greeting message is playing.

A long beep and a short beep will sound. The short beep(s) indicate(s) the number of recorded message(s) up to 8 times.

# 2

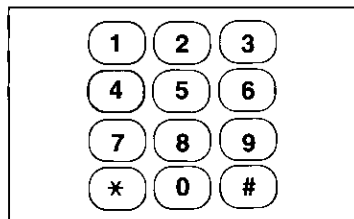

Press **4** within 4 seconds after the short beep(s).

The unit plays back the new messages. At the end of the last message, 3 long beeps will sound.

**NOTES:**

- Even if 9 or more calls are recorded, a short beep sounds 8 times.
- If there is no new message, a short beep does not sound.

## Playing back all messages

You can listen to all the recorded messages from the first message.

1

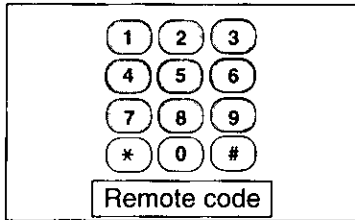

Call your unit and dial your remote code while the greeting message is playing.

2

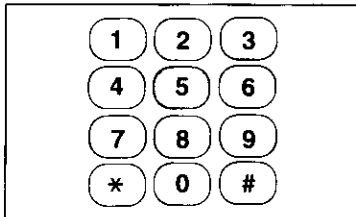

Press 5 within 4 seconds after the short beep(s), or wait for 4 seconds.

The unit plays back all messages.  
At the end of the last message, 3 long beeps will sound.

## Functions during the message playback

You can use the following functions during the message playback.

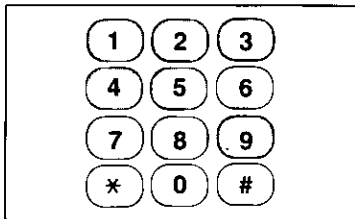

**Replaying newly recorded messages:**

Press 4.

**Replaying all messages:**

Press 5.

**Repeating a message:**

Press 1 to start to play back the previous message.

**Skipping a message:**

Press 2 to start to play the next message.

**Playing back quickly:**

Press 3.

To return to normal speed, press 3 again.

**Stop playback:**

Press 9.

If there is no command within 10 seconds after pressing 9, the unit resumes playback.

## Erasing specific messages from memory

You may erase specific messages.

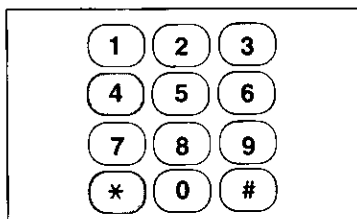

Press \* 4 while the message you want to erase is playing.

A long beep is heard, then the unit plays the next message.

– If you wish to erase the next message, press \* 4 continually until finished.

## Erasing all messages from memory

You may erase all the recorded messages. Your greeting messages are not erased in this operation.

This feature is available after the unit plays back all the messages.

1

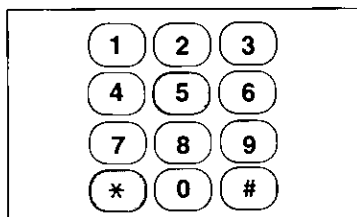

Press \* 5 during all messages playback has been completed, or after 3 long beeps which indicate the playback has been completed.

A long beep is heard.

2

Wait for approximately 10 seconds.

2 long beeps sound and then all messages have been erased from memory.

### NOTES:

- If you wish to cancel the erasing, enter any other commands than \* 5 within 10 seconds before you hear 2 long beeps which indicates the completion of erasing.
- If you press \* 5 after the new messages playback, only new messages are erased.



## Recording a remote memo message

After playing back the recorded messages, you can leave an additional message on the same call.

When a playback is finished, wait for 3 long beeps indicating the end of the last message. And wait for about 10 seconds. You hear 2 long beeps indicating that the unit is ready for recording, then you can leave your message.

## Room monitoring

You can monitor the sound in the room where the unit is installed. This feature also allows you to speak with anyone in the room.

1

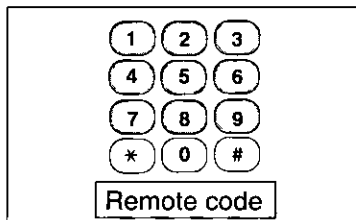

Call your unit and dial your remote code while the greeting message is playing.

2

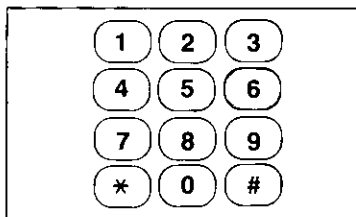

Press **6** within 4 seconds after the short beep(s).

You can monitor the room sound for about 30 seconds.

- When 30 seconds have passed, a long beep sounds and the line will be disconnected.
- To continue monitoring, press 6 again within 10 seconds after hearing the beep.

### NOTES:

- To talk with anyone in the room, inform them to lift the handset or press the SP-PHONE button.
- If the volume level of the unit has been lowered, the other party may not be able to hear your voice from the speaker.

## Skipping the greeting message

Callers can leave their messages on your unit without listening to your greeting message.

1

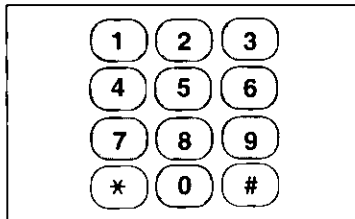

Call your unit and press **0** while the greeting message is playing.

The unit skips the rest of the greeting message and a long beep sounds. Then the unit will be ready to start recording.

2



Leave a message.

## Re-recording a greeting message

You can change the content of your greeting message for the *ANS/FAX* mode.

1

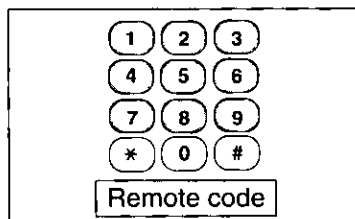

Call your unit and dial your remote code while the greeting message is playing.

2

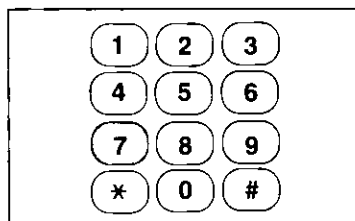

Press **7** within 4 seconds after hearing the short beep(s).

# 3



After a long beep, speak clearly and loudly for up to 16 seconds to re-record your greeting message for the *ANS/FAX* mode.

# 4

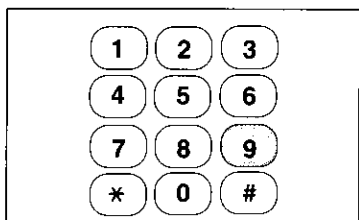

When finished, press **9**.

The new greeting message is playing to confirm the change.

– To re-record your greeting message after confirming the message, repeat from step 2 within 10 seconds.

#### NOTES:

- If you pause for over 2 seconds while recording, 6 short beeps sound and the unit stops recording. In this case, repeat from step 2 within 10 seconds.
- You cannot re-record the greeting message for the *TEL/FAX* mode.



# Making Voice Calls Using Automatic Dialer

The unit's memory allows both one-touch dialing (up to 28 phone numbers) and speed dialing (up to 100 phone numbers) for rapid access to the most frequently called numbers. Before using these features, make sure that the desired telephone numbers have been stored into memory (see pages 81 to 88).

## HELPFUL HINT:

- If you lose your instructions while operating, press the HELP button. The unit will print information on how to operate.

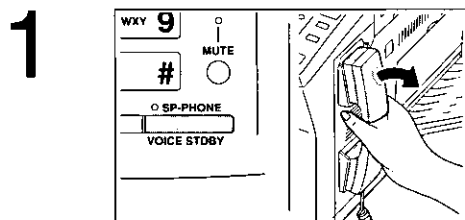

Press **SP-PHONE** or lift the handset and listen for the dial tone.

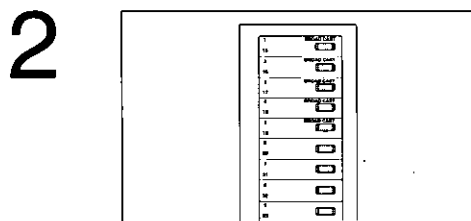

### ■ Using one-touch dialing:

Press the desired direct call station key.

- To use the station number 15 to 28, press **LOWER** then the direct call station key.

or

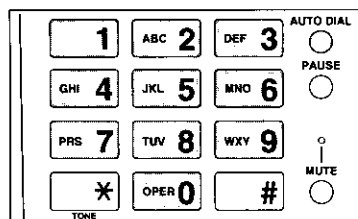

or

### ■ Using speed dialing:

Press **AUTO DIAL**.

Then press the desired station number (00 to 99).

The display shows the station name or station number, and the unit dials automatically.

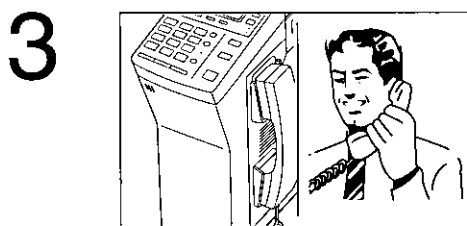

When the other party answers your call, speak through the microphone, or lift the handset and talk into it.

## NOTE:

- If there is no answer or you wish to redial the last dialed number, you can use the REDIAL button. See page 77.

## Making voice calls using the electronic telephone directory

You can make voice calls using the electronic telephone directory feature by selecting the desired name from the display.

Make sure that the desired telephone numbers and their names have been stored into memory (see pages 81 to 88).

1

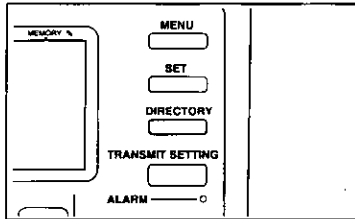

Press **DIRECTORY**.

SELECT INDEX  
A-Z, 0-9, #

2

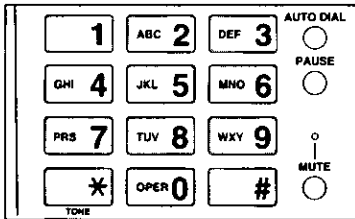

■ **To access the desired index directly:**  
Enter the desired index (see page 96).

The first name in the index is displayed.

SELECT NAME <XXX>  
=XXXXXXXXXX

OR

OR

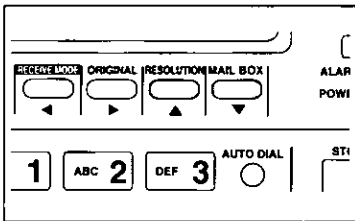

■ **To look up the desired name in alphabetical order:**

Press ▼ or ▲ until the desired name is shown.  
Skip step 3 and go to step 4.

3

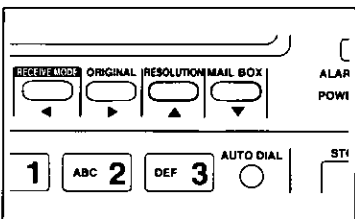

Press ▼ or ▲ until the desired name is shown.  
Use ▼ to advance the stored names, or ▲ to go back.

SELECT NAME <XXX>  
=XXXXXXXXXX

4

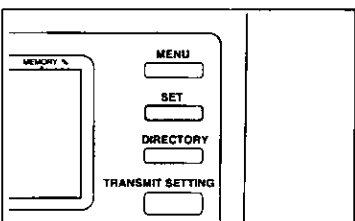

Press **SET**.

AUG10 3:00PM 00 00  
<XXXXXXXXXX>

The unit starts dialing.

3

# Calling Your Unit with the Privacy Ring

---

This feature eliminates interruptions caused by unwanted calls. Only callers with a passcode can activate a distinctive tone to notify you of a priority call.

Entering a unique 3-digit ID number activates this feature. Issue your ID number to callers with priority status. All other calls will be routed to the answering system unless you answer a call.

The unit provides a privacy ring ID number "333" as a pre-selected setting. If you want to change the number, see page 149.

**IMPORTANT:**

- This feature is effective only in the *ANS/FAX* mode.
- To operate this feature, use a touch tone telephone.

## Calling with the privacy ring

*Instructions for a caller:*

1

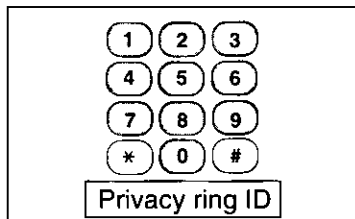

Call your unit and dial your ID number with tone dialing during playing the greeting message or the incoming message recording mode.

- The unit rings with a distinctive tone for 30 seconds.

2



When the other party answers, start speaking.

**NOTE:**

- If nobody answers while the distinctive tone is ringing, the unit will activate the recording feature. To continue ringing, press the ID number again. To stop ringing, press 0. The unit will activate the recording feature.

## Changing the privacy ring ID number

You can choose any number of 3 digits. You should also use a number that is different from the remote code (see page 139) and the mail box passcode (see page 118).

1

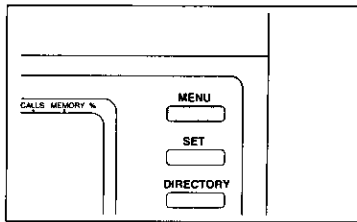

Press **MENU** until the following is shown.

PROG. [1.DATE 2.TEL  
3.SYSTEM 4.REPORT]

2

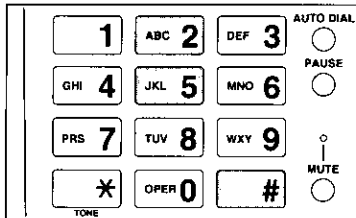

Press #, then press **25** to start programming.

PRIVACY RING ID  
=333

3

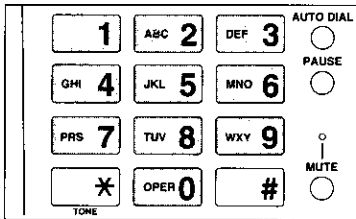

Enter the 3-digit number as the new ID number.

–You can choose among numbers “111” through “999”, except numbers including “0”.

**Example:** The ID is 876.

PRIVACY RING ID  
=876

– To correct an error, use the cursor key (◀ or ▶) to move the cursor to the incorrect number, then make the correction.

4

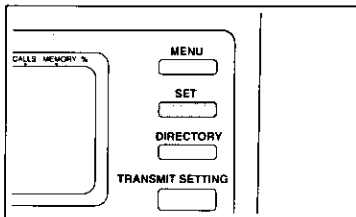

Press **SET** to store your selection into memory.

PROG. [1.DATE 2.TEL  
3.SYSTEM 4.REPORT]

5

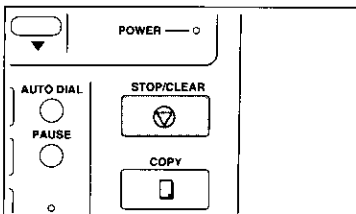

Press **STOP/CLEAR** to end the operation.

3

# Voice Contact

## Initiating voice contact

While transmitting or receiving a document, you may wish to speak to the other party. If the other party's unit is equipped with a voice contact feature, you can initiate voice contact and notify the other party after the transmission/reception has been completed. The other party's unit will emit a distinctive ring indicating that a voice conversation is required.

This saves the extra expense and time of making a subsequent telephone call to discuss information sent over the fax.

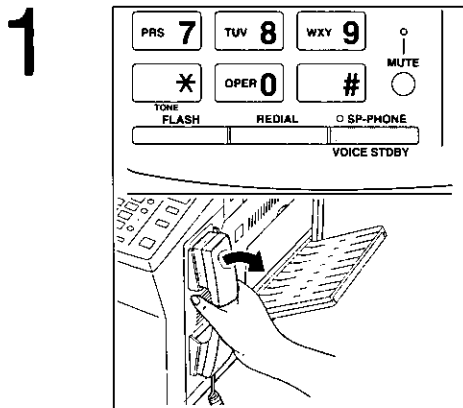

Press **SP-PHONE/VOICE STDBY** or lift the handset while transmitting or receiving the documents.

SENDING PXX  
VOICE STANDBY

or

RECEIVING PXX  
VOICE STANDBY

– If you press **SP-PHONE/VOICE STDBY**, the **SP-PHONE/VOICE STDBY** indicator light is on.

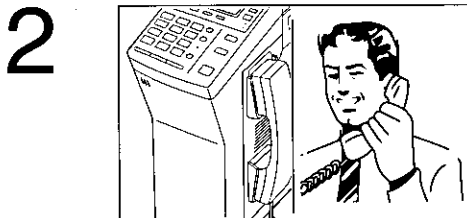

When the other party answers, start speaking.

- If you initiate voice contact while transmitting documents, you can speak after all the documents have been transmitted.
- If you initiate voice contact while receiving documents, you can speak after receiving the current page of the documents.

### Continuing the transmission or reception after voice contact:

#### ■ To continue the transmission:

1. Ask the other party to press their start or transmit button.
2. Listen for the fax tone, and confirm that the documents are loaded in your unit.
3. Press the **START** button.
4. Replace the handset, if using it.

#### ■ To continue the reception:

1. Ask the other party to continue the transmission.
2. Press the **START** button.
  - When the other party begins the transmission, the unit will start receiving documents.
3. Replace the handset, if using it.



## Receiving a request for voice contact

If the other party initiates voice contact during transmission or reception, your unit will emit a distinctive ring after the transmission/reception is completed.

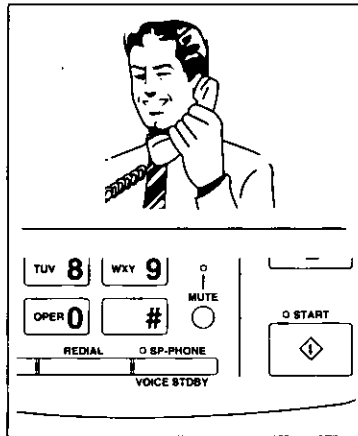

When a distinctive ring is heard, lift the handset, or press **SP-PHONE** then start speaking.

SENDING PXX  
PICK UP THE HANDSET

or

RECEIVING PXX  
PICK UP THE HANDSET

### NOTE:

- If you do not answer within 10 seconds of hearing the distinctive rings, one of the following occurs:
  - When the unit is in the *ANS/FAX* mode, it will play back your greeting message and record the incoming voice-message.
  - When the unit is in the *TEL/FAX*, *FAX* or *TEL* mode, the line is disconnected.

# TONE, FLASH, PAUSE, and MUTE Buttons

## Changing from pulse to tone mode (TONE button)

This function is only effective when your line has a rotary pulse dial service. Pressing the TONE (\*) button will allow the change of the dialing mode to tone mode during a dialing operation. Whichever dial service your line has, you can enter special tones and codes to operate the answering device, electronic banking services, call processing services, and other special services.

Using the TONE button:

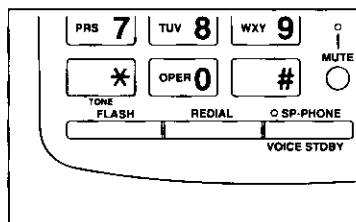

Press **TONE** (\*).

– When you hang up, the unit will automatically return to pulse mode.

### NOTES:

- TONE can be stored into memory (see pages 81 to 88).
- Pressing the TONE button counts as 1 digit while programming.

## Accessing features of your host exchange (FLASH button)

Pressing the FLASH button will allow you to access the special features of your host exchange or local telephone company services.

For further details, contact the supplier or telephone company for information about the availability of services.

Using the FLASH button:

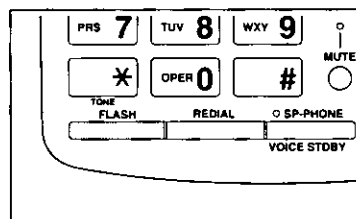

Press **FLASH** lightly when required.

### NOTES:

- FLASH can be stored into memory (see pages 81 to 88).
- Pressing the FLASH button counts as 1 digit while programming.

## Inserting a pause into a phone number (PAUSE button)

If your unit is connected to a private branch exchange (PBX), you need to dial an access number to get an outside line. A pause must be inserted between the access number and the phone number, especially when storing the number into memory or redialing. Pressing the PAUSE button causes a dialing delay in the dialing sequence. If a transmission error occurs frequently when making an overseas transmission, add two pauses at the end of the phone number.

Using the PAUSE button:

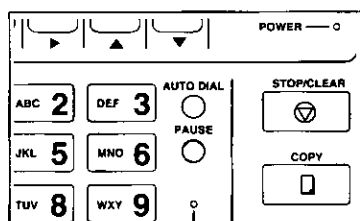

Press **PAUSE** when required.

**Example-1:** Dial or store the phone numbers as follows when the line access number of your exchange is 9.

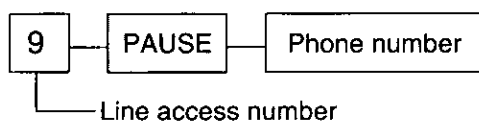

**Example-2:** Dial or store the phone numbers as follows to make an overseas transmission.



### NOTES:

- PAUSE can be stored into memory (see pages 81 to 88).
- Pressing the PAUSE button counts as 1 digit while programming.

## Voice muting (MUTE button)

The MUTE button will mute your voice during a telephone conversation. You can hear the voice of the other party, but the other party cannot hear your voice.

Using the MUTE button:

### ■ To mute your voice:

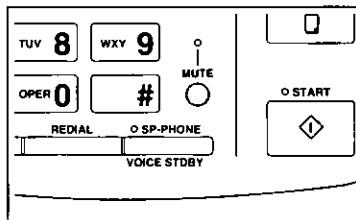

Press **MUTE** during a conversation.

The MUTE indicator light is on.

– Your voice is not heard by the other party.

### ■ To resume the conversation:

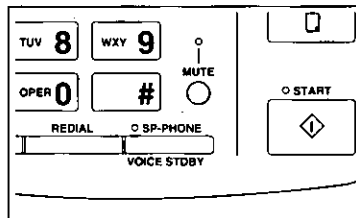

Press **MUTE** again.

The MUTE indicator light goes out.

## Reserve Phone

---

If you connect a reserve telephone on the same line to which your facsimile unit is connected, you can make and answer voice calls by using the reserve telephone. You can also initiate fax reception.

Remember the following notice when using the reserve telephone.

When a call comes in, the reserve telephone will ring according to the setting of the receiving mode of your facsimile unit as follows:

■ **When receiving a call in the *ANS/FAX* mode:**

Both the reserve telephone and your facsimile unit ring depending on the setting of the number of rings in the *ANS/FAX* mode before your facsimile unit automatically switches to the answering device.

- You can change the ring count. See page 163.
- If you set to “RINGER OFF” in its ring count selection, your facsimile unit will not ring. But the reserve phone will ring once.

■ **When receiving a call in the *TEL/FAX* mode:**

Before your facsimile unit rings, the reserve telephone rings depending on the setting of the number of rings of the reserve telephone.

- You can change the ring count of the reserve telephone. See page 182.
- If someone does not answer the call with the reserve telephone, your facsimile unit will ring depending on the setting of the silent fax recognition ring (see page 170). In this case, your facsimile unit will play the greeting message and emit the distinctive tone to the caller.
- An automatic fax transmission call will be received without ringing after the reserve phone rings.

■ **When receiving a call in the *FAX* mode:**

Both the reserve telephone and your facsimile unit ring depending on the setting of the number of rings in the *FAX* mode before your facsimile unit automatically switches to fax.

- You can change the ring count. See page 162.

■ **When receiving a call in the *TEL* mode:**

Both the reserve telephone and your facsimile unit continue ringing until someone answers the call. If someone does not answer the call before the unit rings 15 times, your facsimile unit will automatically switch to the *ANS/FAX* mode.

If a power failure occurs, your facsimile unit will not function. We recommend using the reserve telephone as a standard telephone.

**NOTE:**

- When a reserve telephone is connected to the same line, do not use the reserve telephone during fax transmission and reception. Otherwise image quality will be affected.

# Remote Fax Receiving Using a Reserve Phone

If you connect a reserve telephone to the same line to which your facsimile unit is connected, it is possible to receive a fax document into your facsimile unit by using the reserve telephone near you.

This saves you the trouble of going to the facsimile unit and pressing the START button.

## NOTES:

- This feature is only effective when you receive a call.
- This feature can only be used when the reserve phone is touch tone telephone.

## Receiving documents by operation of reserve phone

1

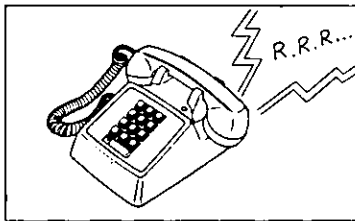

When a call comes in, lift the handset of the reserve phone to answer the call.

2

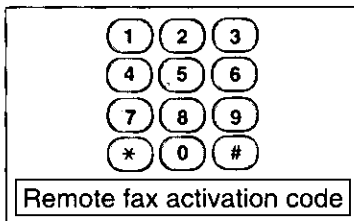

When the other party wishes to send you a fax, or nothing is heard, press the remote fax activation code using your reserve phone.

- The pre-selected code is \* \* .
- Remote fax activation code can be changed (see page 157).

3

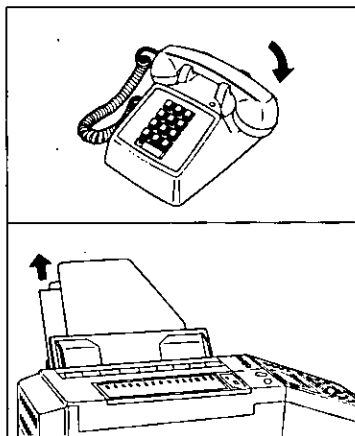

Replace the handset on the cradle.

The unit switches to the fax mode, then receives a document.

## Changing a remote fax activation code

Your code can be from 2 to 4 digits in length. The numbers 0 through 9 and characters # and \* may be used. (Example: \*0, 123, 123#)

1

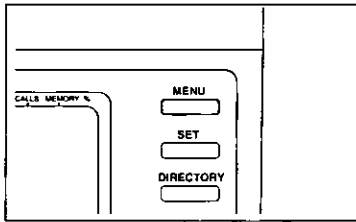

Press **MENU** until the following is shown.

PROG. [1.DATE 2.TEL  
3.SYSTEM 4.REPORT]

2

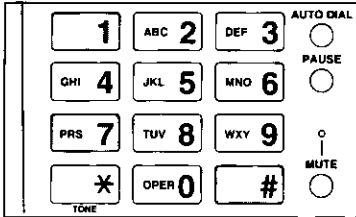

Press #, then press 17 to start programming.

REMOTE FAX ACT.  
CODE= . . \*

3

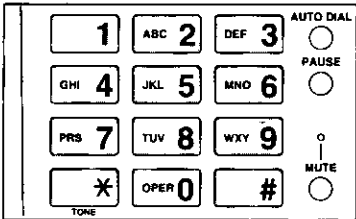

Enter the desired code number.

4

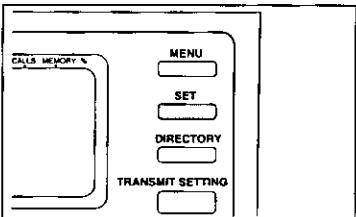

Press **SET** to store your selection into memory.

PROG. [1.DATE 2.TEL  
3.SYSTEM 4.REPORT]

5

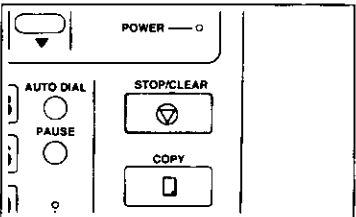

Press **STOP/CLEAR** to end the operation.

### NOTE:

– If the remote fax activation code is set to "00", "000" or "0000", the remote fax receiving does not work properly.





# ***Chapter 4***

## ***Registration***

# Setting the Individual Transmission Report Printing

Once fax transmission has terminated, the unit will print a record of the transmission.

The following selections are available:

**ERROR:** The report will print only when the transmission fails (pre-selected setting).

**ON:** The report will print, indicating whether the transmission is successful or not.

**OFF:** The report will not print.

## Sample of the transmission report:

```

***** XMT REPORT *****
*
*                                     AUG. 10. 1994 4:20PM
*
* No.  OTHER FACSIMILE  START TIME  USAGE TIME  MODE  PAGES  RESULT
* 01  092 477 1237    AUG. 10  4:20PM   00'56   TX     02    OK
*
*
*
*
*
*
*
*****
  
```

① Print date and time

② Communication number

③ Dialed number or other party's name  
(Maximum 20 characters)

④ Communication start time

⑤ Length of communication  
(Maximum 59' 59")

⑥ Transaction mode:

TX.....Transmission

MAIL TX ... Transmission from mail box

⑦ Number of pages transmitted successfully  
(Maximum 99 pages)

⑧ Communication result

### NOTE:

- For the explanation of communication results, see page 195.

To change the individual transmission report setting, proceed as follows:

**HELPFUL HINT:**

- If you lose your instructions while programming, press the HELP button. The unit will print information on how to program.

1

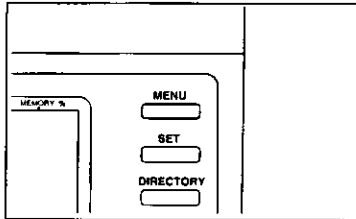

Press **MENU** until the following is shown.

PROG. [1.DATE 2.TEL  
3.SYSTEM 4.REPORT]

2

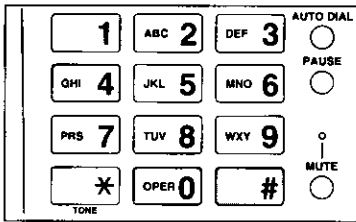

Press #, then press **04** to start programming.

XMT REPORT =ERROR  
[1.ERROR 2.ON 3.OFF]

3

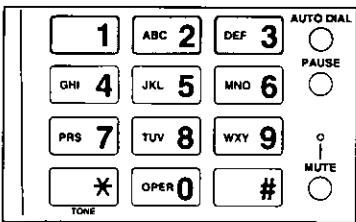

Enter the number of the selection you desire.

Setting selections:

- 1: ERROR (only when any trouble occurred)
- 2: ON (everytime after transmission)
- 3: OFF (de-activation of this feature)

4

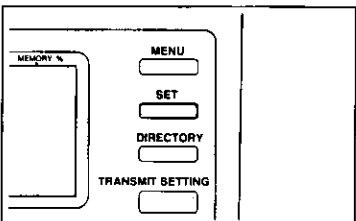

Press **SET** to store your selection into memory.

PROG. [1.DATE 2.TEL  
3.SYSTEM 4.REPORT]

5

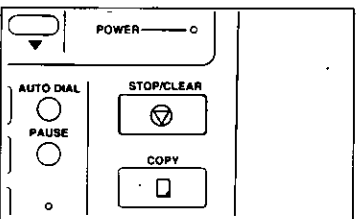

Press **STOP/CLEAR** to end the operation.



# Selecting the Number of Rings in the FAX Mode \_\_\_\_\_

When receiving a call in the *FAX* mode, the unit will automatically answer on the first ring as a pre-selected setting. You can change the number of rings to answer a call from 1 to 4.

## HELPFUL HINTS:

- If you wish to have the opportunity to pick up the handset before the call is answered by the unit, increase the number of rings.
- If there is difficulty in receiving faxes from machines that have an automatic transmission feature, decrease the number of rings.
- If you lose your instructions while programming, press the HELP button. The unit will print information on how to program.

To change the number of rings in the *FAX* mode, proceed as follows:

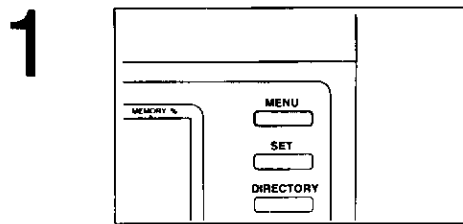

Press **MENU** until the following is shown.

PROG. [1.DATE 2.TEL  
3.SYSTEM 4.REPORT]

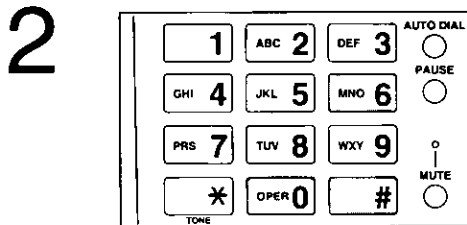

Press #, then press **06** to start programming.

FAX RING  
COUNT=1 [1-4]

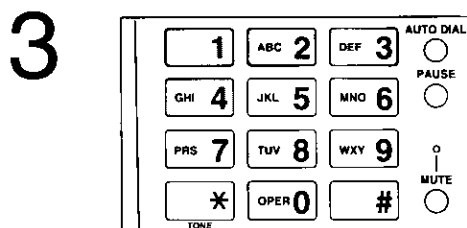

Enter the desired number of rings from 1 to 4.

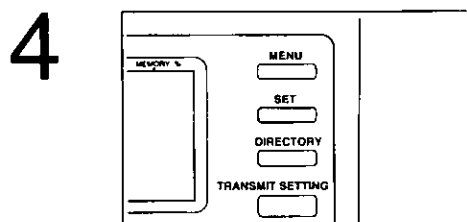

Press **SET** to store your selection into memory.

PROG. [1.DATE 2.TEL  
3.SYSTEM 4.REPORT]

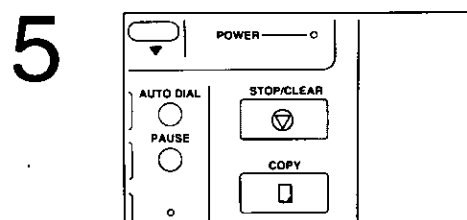

Press **STOP/CLEAR** to end the operation.

# Selecting the Number of Rings in the ANS/FAX Mode

When receiving a call in the ANS/FAX mode, the unit will automatically answer on the first ring as a pre-selected setting.

If you wish to change the number of rings to answer a call, you can choose among the following:

- 0: Toll Saver (see page 164)
- 1: The unit answers on the first ring (pre-selected setting).
- 2: The unit answers on the second ring.
- 3: The unit answers on the third ring.
- 4: The unit answers on the fourth ring.
- \*: The unit will not ring. (RINGER OFF)

## HELPFUL HINTS:

- If you wish to have the opportunity to pick up the handset before the call is answered by the unit, increase the number of rings.
- If there is difficulty in receiving faxes from machines that have an automatic transmission feature, decrease the number of rings.
- To confirm from a remote phone whether a new incoming message has been recorded or not, select "0" (Toll Saver). This will save you the toll charge for the call.
- If you lose your instructions while programming, press the HELP button. The unit will print information on how to program.

To change the number of rings in the ANS/FAX mode, proceed as follows:

1

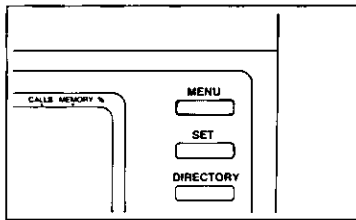

Press **MENU** until the following is shown.

```
PROG. [1. DATE 2. TEL
3. SYSTEM 4. REPORT]
```

2

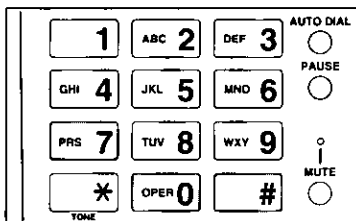

Press #, then press **07** to start programming.

```
ANS/FAX RING
COUNT=1      [0-4, *]
```

3

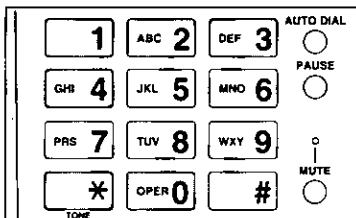

Enter the number of the selection you desire.

Setting selections are:

- 0: Toll Saver
- 1: one ring
- 2: two rings
- 3: three rings
- 4: four rings
- \*: RINGER OFF



4

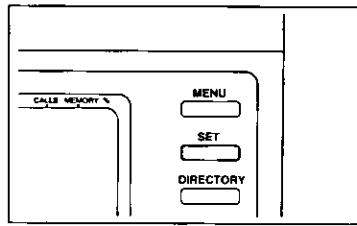

Press **SET** to store your selection into memory.

PROG. [1.DATE 2.TEL  
3.SYSTEM 4.REPORT]

5

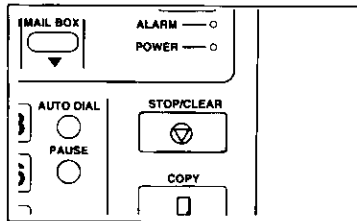

Press **STOP/CLEAR** to end the operation.

**Toll Saver:**

When you call the unit from a remote location, the number of rings tells you if there are any new voice-messages.

If the unit answers on the second ring, there is at least one new message recorded.

If the unit answers on the fourth ring, there are no newly recorded messages.

Hang up immediately when you hear the third ring. The third ring indicates that there are no new messages. This will save you the toll charge for the call.

**NOTE:**

– If you set to “RINGER OFF”, the reserve phone connected to the unit will ring once when receiving a call.

# Selecting the Caller's Recording Time

You can choose from two lengths of recording times for incoming messages.

**VOX (Unlimited):** The unit records an incoming message as long as a caller speaks (pre-selected setting).

**1 MIN (1 minute):** The unit records an incoming message up to 1 minute per message.

To change the recording time, proceed as follows:

1

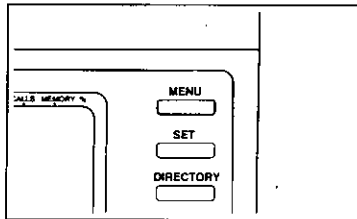

Press **MENU** until the following is shown.

PROG. [1.DATE 2.TEL  
3.SYSTEM 4.REPORT]

2

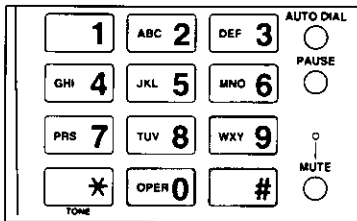

Press #, then press **09** to start programming.

RECORD TIME=VOX  
[1.VOX 2.1MIN]

3

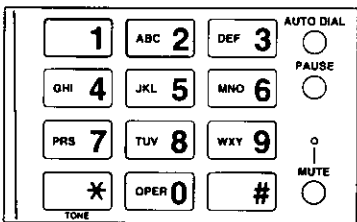

Press the number of the selection you desire.

Setting selections are:  
1: VOX (unlimited)  
2: 1 MIN (1 minute)

4

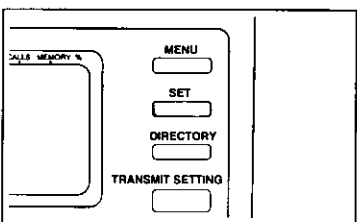

Press **SET** to store your selection into memory.

PROG. [1.DATE 2.TEL  
3.SYSTEM 4.REPORT]

5

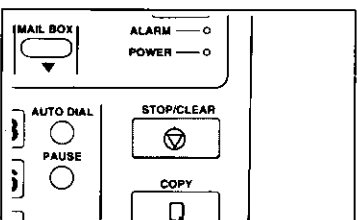

Press **STOP/CLEAR** to end the operation.

4

# Setting the Logo Print Position

Your logo, your telephone number, date, time, and page number will be printed on the transmitted document from your unit in the following manner:

**OUT:** Outside of the transmitted document's paper size (pre-selected setting).

**IN:** Inside of the transmitted document's paper size.

To change the setting, proceed as follows:

1

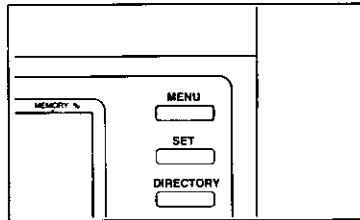

Press **MENU** until the following is shown.

PROG. [1.DATE 2.TEL  
3.SYSTEM 4.REPORT]

2

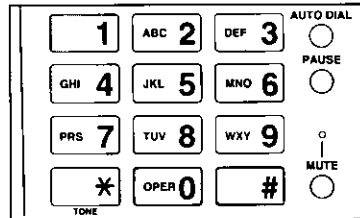

Press #, then press **10** to start programming.

LOGO POSITION=OUT  
[1.OUT 2.IN]

3

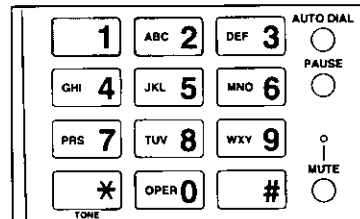

Press the number of the selection you desire.

Setting selections:  
1: OUT (Outside)  
2: IN (Inside)

4

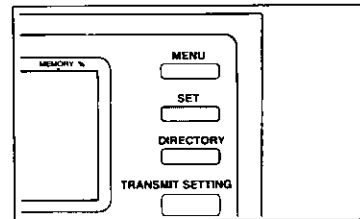

Press **SET** to store your selection into memory.

PROG. [1.DATE 2.TEL  
3.SYSTEM 4.REPORT]

5

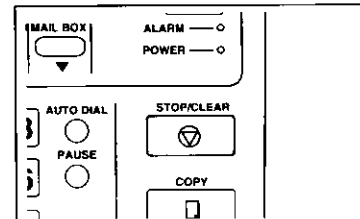

Press **STOP/CLEAR** to end the operation.



# Setting the Journal Report Printing

You can obtain a record of the last 30 fax operations (transmissions and receptions) automatically or manually. This report is useful for keeping transaction records or for verifying call charges.

**AUTO:** The journal report will automatically print after 30 fax operations. After that, the journal report data will clear and the unit will begin to store data of the journal report into memory (pre-selected setting).

**MANUAL:** The journal report will not print automatically. But the journal report data will be stored in memory. When memory is full and the last fax operation takes place, the earliest data will be erased and the newest data will be stored.

Regardless of above setting, the journal report is available whenever you request. See page 169.

## Sample of the journal report:

***** JOURNAL *****							
AUG. 11. 1994 11:38AM							
* No.	OTHER FACSIMILE	START TIME	USAGE TIME	MODE	PAGES	RESULT	*CODE
* 01	0924759269	AUG. 10 5:55PM	00'22	TX	00	PRESSED THE STOP KEY	
* 02	092 987 6543	AUG. 10 5:57PM	00'59	TX	00	PRESSED THE STOP KEY	
* 03	092 987 6543	AUG. 10 5:58PM	00'07	TX	00	NO DOCUMENT	
* 04	092 987 6543	AUG. 10 5:59PM	00'44	TX	01	OK	
* 05	092 987 6543	AUG. 10 6:01PM	00'25	RX	00	COMMUNICATION ERROR	(71)
* 06	INCOMING	AUG. 10 6:02PM	00'08	RX	00	COMMUNICATION ERROR	(54)
* 07	092 987 6543	AUG. 10 6:03PM	01'01	TX	00	COMMUNICATION ERROR	(42)
* 08	0987654321	AUG. 10 6:06PM	00'43	TX	01	OK	
* 09	0929876543	AUG. 10 6:07PM	00'08	TX	00	NO DOCUMENT	
* 10	0929876543	AUG. 10 6:07PM	00'08	TX	00	NO DOCUMENT	
* 11	<A00>	AUG. 10 6:08PM	00'41	TX	00	NO RESPONSE	
* 12	0929876543	AUG. 10 6:09PM	00'44	TX	01	OK	
* 13	0922582580	AUG. 11 11:36AM	00'08	TX	00	PRESSED THE STOP KEY	
* 14	0922582580	AUG. 11 11:36AM	00'46	TX	01	OK	

① Print date and time

② Communication number (up to 30)

③ Dialed number or other party's name (Maximum 20 characters)

④ Communication start time

⑤ Length of communication (Maximum 59'59")

⑥ Transaction mode:

TX ..... Transmission

RX ..... Reception

POL.TX ..... Transmission by polled

POL.RX ..... Reception by polling

FORW.TX .... Transmission by forwarding

FORW.RX ... Reception for forwarding

MAIL TX ..... Transmission from mail box

MAIL.RX ..... Reception into mail box

⑦ Number of pages received or transmitted successfully (Maximum 99 pages)

⑧ Communication result

⑨ Error code (For service personnel use only.)

### NOTE:

- For the explanation of communication results, see page 195.

## Printing the journal report automatically

1

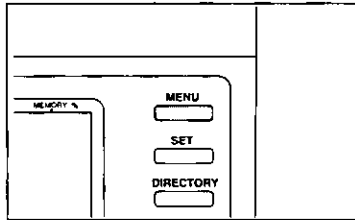

Press **MENU** until the following is shown.

PROG. [1.DATE 2.TEL  
3.SYSTEM 4.REPORT]

2

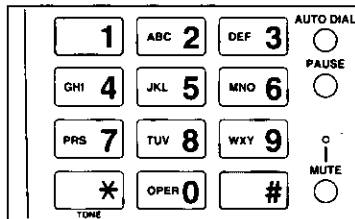

Press #, then press **11** to start programming.

JOURNAL=AUTO  
[1.AUTO 2.MANUAL]

3

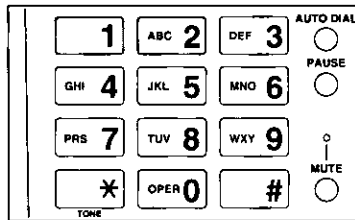

Press the number of the selection you desire.

Setting selections:

- 1: AUTO (automatic journal report printing)
- 2: MANUAL (not automatic printing)

4

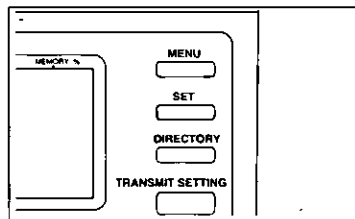

Press **SET** to store your selection into memory.

PROG. [1.DATE 2.TEL  
3.SYSTEM 4.REPORT]

5

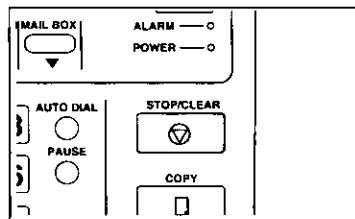

Press **STOP/CLEAR** to end the operation.

## Printing the journal report manually

Upon request, a report of the current journal can be printed. The journal report data will not be cleared even after printing.

1

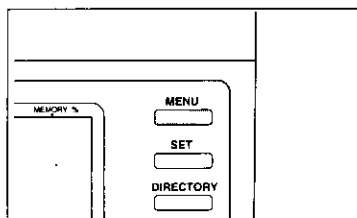

Press **MENU** until the following is shown.

PROG. [1.DATE 2.TEL  
3.SYSTEM 4.REPORT]

2

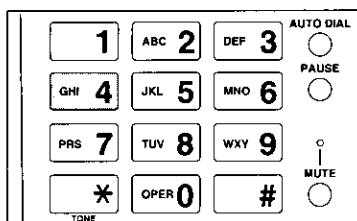

Press **4** to start programming.

SELECT NO. [1.SYSTEM  
2.TEL NO. 3.JOURNAL]

3



Press **3** to print the journal report.

The unit starts printing.

PRINTING JOURNAL

– If there have been no fax operation, a journal report will not be printed.

4

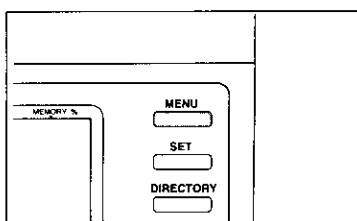

After printing, press **MENU** to end the operation.

4

# Selecting the Number of Fax Recognition Rings \_\_\_\_\_

When a manual fax transmission or a voice call is received in the *TEL/FAX* mode, the unit will emit the distinctive ring three times as a pre-selected setting until it will automatically switch to fax. (We call this ring "silent fax recognition ring".)

When an automatic fax transmission is received in the *TEL/FAX* mode, the unit will receive the fax without ringing.

You can change the number of the fax recognition rings from 3 to 8.

## IMPORTANT:

- This feature is effective only in the *TEL/FAX* mode.
- Telephone fees will be charged to the calling party from the first ring because the unit emits the rings after answering a call.

To change the number of rings, proceed as follows:

1

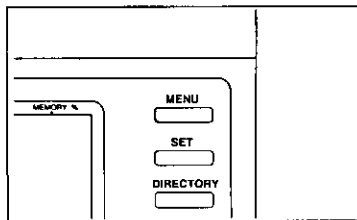

Press **MENU** until the following is shown.

PROG. [1.DATE 2.TEL  
3.SYSTEM 4.REPORT]

2

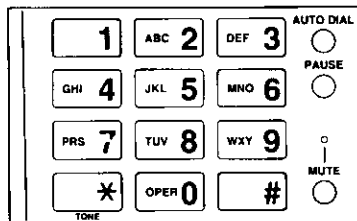

Press **#**, then press **16** to start programming.

SILENT FAX RECO.  
RING COUNT=3 [3-8]

3

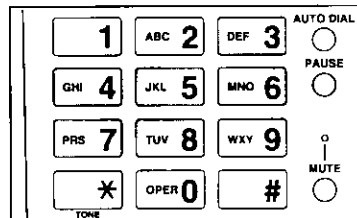

Enter the desired number of rings from 3 to 8.

4

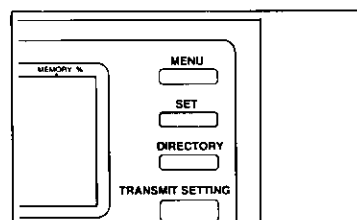

Press **SET** to store your selection into memory.

PROG. [1.DATE 2.TEL  
3.SYSTEM 4.REPORT]

5

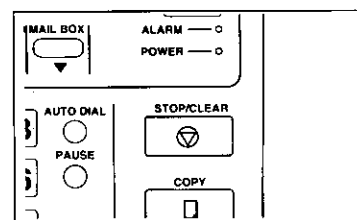

Press **STOP/CLEAR** to end the operation.

# Setting the Copy Mode

This mode determines how a copy will be reproduced. One of the following three settings can be selected.

**REDUCT:** Copies will be reduced to either 86% or 72% of their original length so that they will fit on one page. If an original is large and can not be reduced to fit on one page, the unit will print the copy on two pages without reduction (pre-selected setting).

**INHIBIT:** Copies will not be reduced. The unit will print the copies on two pages without reduction.

**EXTEND:** Copies will be extended to 108%, 116%, or 138% of their original length. If a legal-size original is copied, the copy will be printed on two pages. This mode is useful to enlarge received documents that have been reduced by the receiving reduction feature (see page 175).

To make extension copies, see page 173.

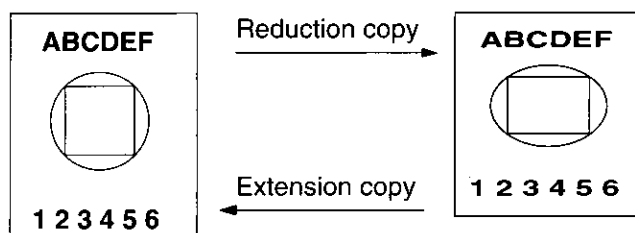

## Setting the reduction or inhibition mode

1

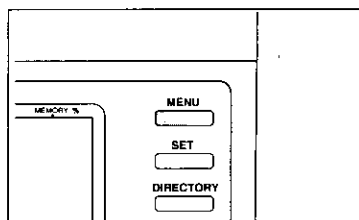

Press **MENU** until the following is shown.

PROG. [1.DATE 2.TEL  
3.SYSTEM 4.REPORT]

2



Press **#**, then press **19** to start programming.

COPY MODE=REDUCT  
1.REDT 2.INH 3.EXTND

3

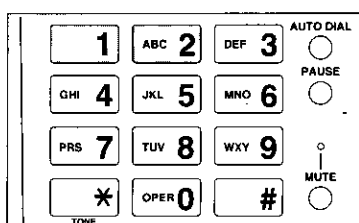

Enter the number of the selection you desire.

Setting selections:  
1: REDT (Reduction)  
2: INH (Inhibition)

**NOTE:**

– To make extension copies by selecting EXTND, see page 173.

(continued)

4

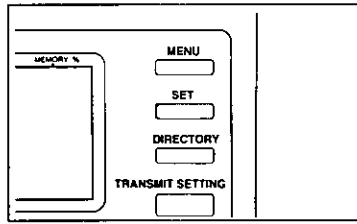

Press **SET** to store your selection into memory.

PROG. [1.DATE 2.TEL  
3.SYSTEM 4.REPORT]

5

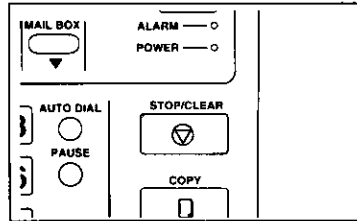

Press **STOP/CLEAR** to end the operation.

- To make copies in the selected copy mode, perform the same procedure for making copies (see page 66).

■ Reduction rate in length:

Size of recording paper	Selections	Size of original document		
		Letter	A4	Legal
Letter 216 × 279 mm (8½" × 11")	REDUCT	100%	86%	72%
	INHIBIT	Divided	Divided	Divided
Legal 216 × 356 mm (8½" × 14")	REDUCT	100%	100%	100%
	INHIBIT	100%	100%	Divided

**NOTE:**

- A4 size paper may not be available in the United States and Canada.

## Making extension copies

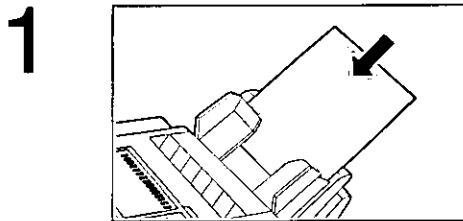

Insert documents FACE DOWN.

– The unit can accept up to 20 pages at a time.

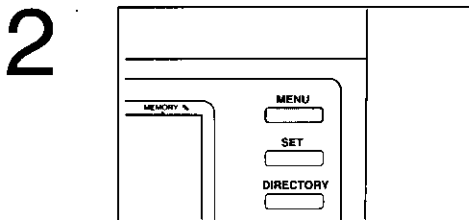

Press **MENU** until the following is shown.

PROG. [1.DATE 2.TEL  
3.SYSTEM 4.REPORT]

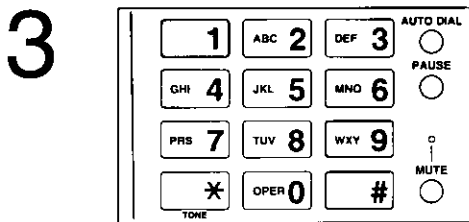

Press #, then press **19** to start programming.

COPY MODE=REDUCT  
1.REDT 2.INH 3.EXTND

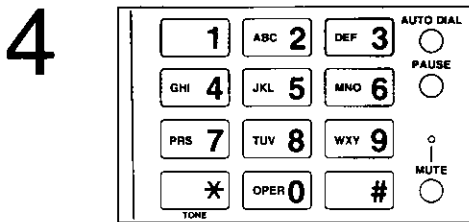

Press **3** to select the extension copy mode.

COPY MODE=EXTND  
1.REDT 2.INH 3.EXTND

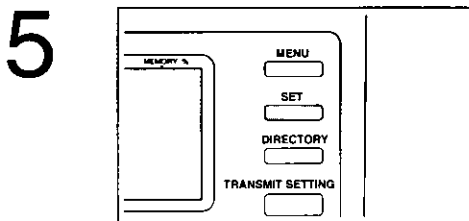

Press **SET** to store your selection into memory.

EXTEND COPY=108%[A]  
[1.A 2.B 3.C]

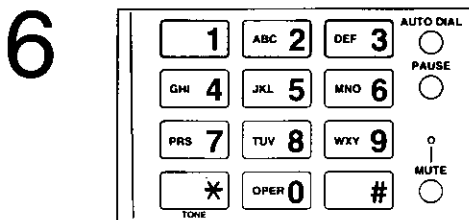

Enter the number of the selection you desire.

Setting selections:

- 1: A (extension rate in length 108%)
- 2: B (extension rate in length 116%)
- 3: C (extension rate in length 138%)

(continued)

4

7

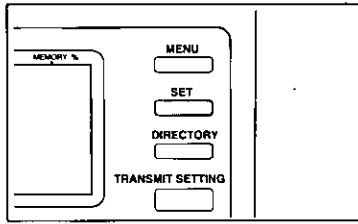

Press **SET** to store your selection into memory.

```
AUG10  3:00PM 00 00
NUMBER OF COPIES=1
```

- If you need two or more copies, enter the number of copies (up to 70).

8

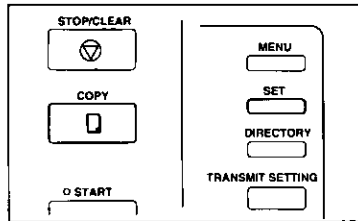

Press **COPY** or **SET** to start making extension copies.



# Setting the Receiving Reduction Mode

When receiving a document that is as long or longer than the recording paper installed in your unit, the unit will automatically reduce the data of the document when printing it out. The unit can receive documents in actual size by changing the following copy mode.

**REDUCT1:** The unit reduces the size of the incoming document to 92% in length to fit on one page. If, after reduction, the unit cannot fit the document on one page, the document will be printed on two pages without reduction.

**REDUCT2:** The unit reduces the size of the incoming document to 92%, 86%, or 72% in length to fit on one page. If, after reduction, the unit cannot fit the document on one page, the document will be printed on two pages without reduction (pre-selected setting).

**INHIBIT:** Documents are not reduced. Incoming documents are printed on two pages.

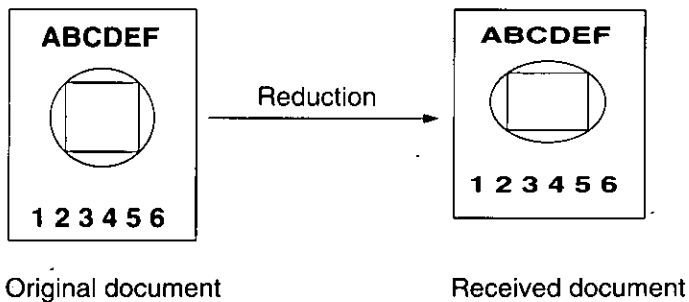

To change the reduction mode, proceed as follows:

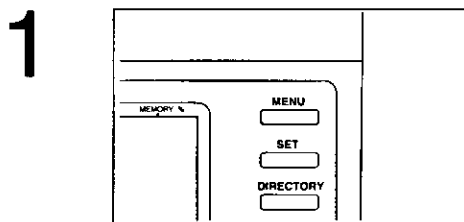

Press **MENU** until the following is shown.

```

PROG. [1.DATE 2.TEL
3.SYSTEM 4.REPORT]
    
```

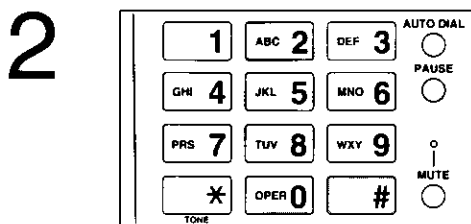

Press **#**, then press **20** to start programming.

```

RX REDUC.=REDUCT2
1.RED1 2.RED2 3.INH
    
```

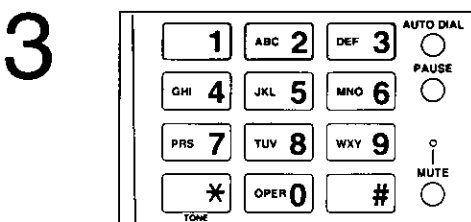

Enter the number of the selection you desire.

- Setting selections:
- 1: RED1 (Reduction1)
  - 2: RED2 (Reduction2)
  - 3: INH (Inhibition)

(continued)

4

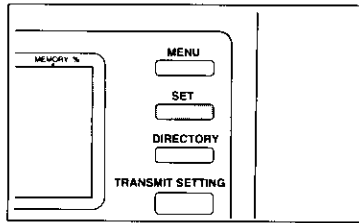

Press **SET** to store your selection into memory.

PROG. [1.DATE 2.TEL  
3.SYSTEM 4.REPORT]

5

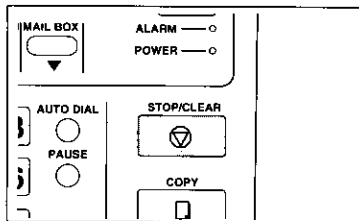

Press **STOP/CLEAR** to end the operation.

■ Reduction rate in length:

Size of recording paper	Selections	Size of document sent by the other party		
		Letter	A4	Legal
Letter 216 × 279 mm (8½" × 11")	REDUCT1	92%	Divided	Divided
	REDUCT2	92%	86%	72%
	INHIBIT	Divided	Divided	Divided
Legal 216 × 356 mm (8½" × 14")	REDUCT1	100%	100%	92%
	REDUCT2	100%	100%	92%
	INHIBIT	100%	100%	Divided

**NOTE:**

– A4 size paper may not be available in the United States and Canada.

## Additional Feature for Distinctive Ring Service ---

This unit has been equipped with a ring pattern detection feature, which allows more effective use of the distinctive ring service provided by some telephone companies.

The distinctive ring service provides up to 3 phone numbers on your regular single telephone line, each with a different ringing pattern. You may use one of the phone numbers as a facsimile number. With the ring pattern detection feature, your unit will detect its own distinctive ringing pattern and automatically activate the fax function to receive documents. If other calls come in, the unit will answer in the receiving mode selected by the RECEIVE MODE button.

■ The table below shows how the unit answers when receiving calls.

Receiving call	Receiving mode of your unit			
	ANS/FAX	TEL/FAX	FAX	TEL
A call with distinctive ringing pattern	The unit activates the fax function.*	The unit activates the fax function.**	The unit activates the fax function.	The unit rings until you pick up. If you do not answer the call until 15 rings, the unit automatically switch to the ANS/FAX mode.
Other call	The unit activates as an answering device and/or facsimile.*	The unit will ring until you pick up.		

\* The unit answers the call depending on the setting of the number of rings in the ANS/FAX mode.

\*\* When the unit receives a call with its own distinctive ringing pattern in the TEL/FAX mode, other reserve phone, if connected on the same line, will ring before the unit answers the call. To change the number of rings, see page 162.

### Programming your unit with distinctive ringing pattern

To activate this feature, program the ringing pattern of the phone number to be used as a facsimile number.

Ringing patterns that can be programmed:

- A: Standard ring
- B: Double ring
- C: Triple ring (Short-long-short)
- D: Other triple ring
- OFF: De-activated this feature (pre-selected setting)

(continued)

1

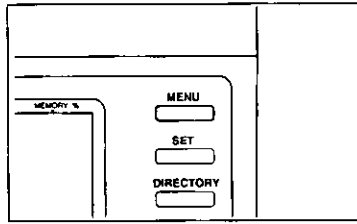

Press **MENU** until the following is shown.

PROG. [1.DATE 2.TEL  
3.SYSTEM 4.REPORT]

2

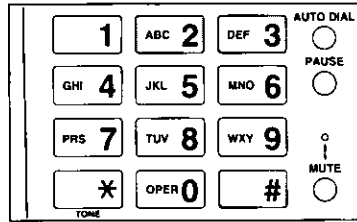

Press #, then press **23** to start programming.

The display shows the current setting.

RING DETECT=OFF [1.A  
2.B 3.C 4.D 5.OFF]

3

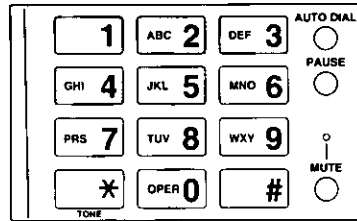

Enter the number of the selection you desire.

Setting selections:

- 1: A (Standard ring)
- 2: B (Double ring)
- 3: C (Triple ring:Short-long-short)
- 4: D (Other triple ring)
- 5: OFF (de-activation of this feature)

4

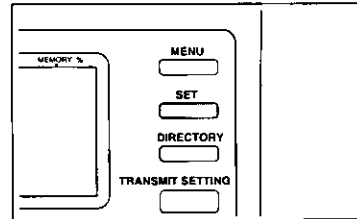

Press **SET** to store your selection into memory.

PROG. [1.DATE 2.TEL  
3.SYSTEM 4.REPORT]

5

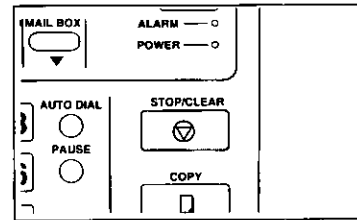

Press **STOP/CLEAR** to end the operation.

# Adjusting the Display Contrast

You can choose the brightness of the display among three levels (light, normal, or dark).  
 "Normal contrast" is pre-selected.

1

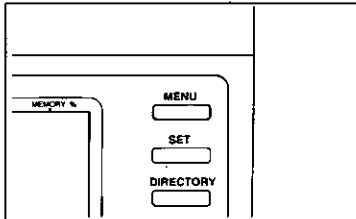

Press **MENU** until the following is shown.

```

    PROG. [1.DATE 2.TEL
           3.SYSTEM 4.REPORT]
    
```

2

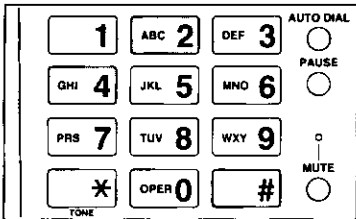

Press #, then press **24** to start programming.

The display shows the current setting.

```

    LCD CONTRAST=NORM
    1.LIGH 2.NORM 3.DARK
    
```

3

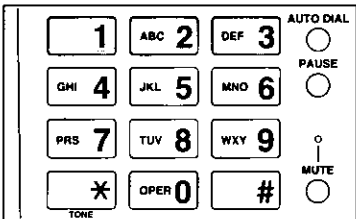

Enter the number of the selection you desire.

Setting selections:

- 1: LIGH (Light)
- 2: NORM (Normal)
- 3: DARK (Dark)

The brightness of the display becomes darker or lighter according to your selection.

4

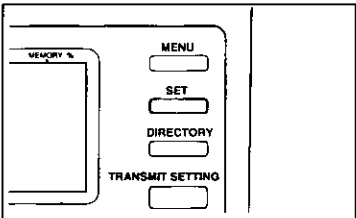

Press **SET** to store your selection into memory.

```

    PROG. [1.DATE 2.TEL
           3.SYSTEM 4.REPORT]
    
```

5

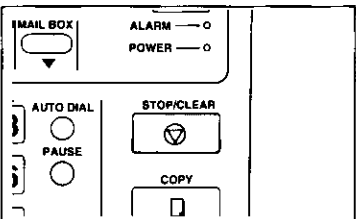

Press **STOP/CLEAR** to end the operation.

4

# Setting the Day/Night Mode

You may wish to use the unit as a telephone and facsimile (*TEL/FAX* mode) during the business hours and switch to the answering device (*ANS/FAX* mode) during off hours. With this feature on, the unit will automatically switch the receiving mode at a preprogrammed time without the operator's assistance.

1

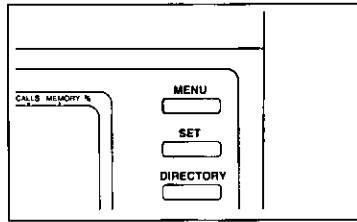

Press **MENU** until the following is shown.

```

PROG. [1.DATE 2.TEL
      3.SYSTEM 4.REPORT]
    
```

2

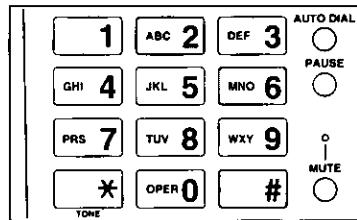

Press #, then press **26** to start programming.

```

DAY/NIGHT
=OFF [1.ON 2.OFF]
    
```

3

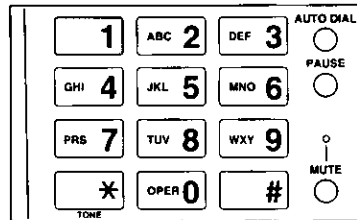

Press **1** to turn on this feature.

```

DAY/NIGHT
=ON [1.ON 2.OFF]
    
```

- To de-activate this feature, press **2**, then go to step 8.

4

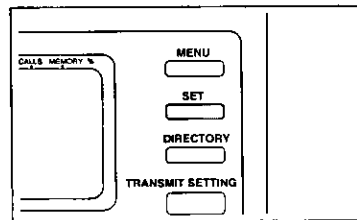

Press **SET** to store your selection into memory.

```

SET DAY MODE TIME
12:00AM [*=AM #=PM]
    
```

5

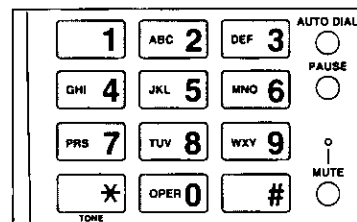

Enter the time at which the Day mode (*TEL/FAX* mode) starts.

**Example:** The *TEL/FAX* mode starts at 9:00AM.  
Press **0900**, then press \* to select AM.

```

SET DAY MODE TIME
09:00AM [*=AM #=PM]
    
```

6

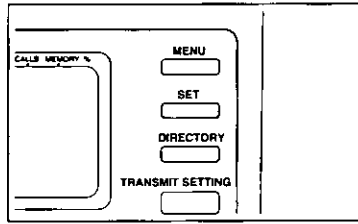

Press **SET**.

SET NIGHT MODE TIME  
12:00AM [.=AM #=PM]

7

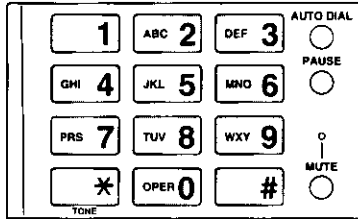

Enter the time at which the unit switches to the Night mode (*ANS/FAX* mode).

**Example:** The *ANS/FAX* mode starts at 5:00PM.  
Press **0 5 0 0**, then press **#** to select PM.

SET NIGHT MODE TIME  
05:00PM [.=AM #=PM]

8

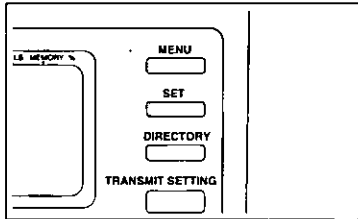

Press **SET** to store your selection into memory.

PROG. {1.DATE 2.TEL  
3.SYSTEM 4.REPORT}

9

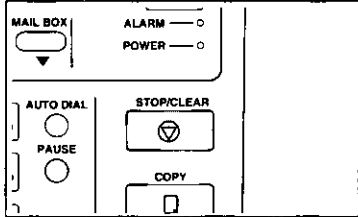

Press **STOP/CLEAR** to end the operation.

**NOTE:**

– If you select another receiving mode manually while this feature is on, the unit keeps the receiving mode that you select until either day or night mode starts.



# Selecting the Number of Rings of Reserve Phone \_\_\_\_\_

If your unit is set in the *TEL/FAX* mode, the reserve telephone, connected to the same line as your facsimile unit, will ring once (pre-selected setting) when receiving a call. After that, your facsimile unit will ring with the distinctive tone depending on the setting of the silent fax recognition ring (see page 170). You can change the number of rings of the reserve telephone from 1 to 4 by programming your unit. While your facsimile unit is ringing, the reserve telephone does not ring any more.

## HELPFUL HINTS:

- If you wish to have the opportunity to answer a call by using the reserve telephone before the call is answered by your facsimile unit, increase the number of rings.
- If there is difficulty in receiving faxes from machines that have an automatic transmission feature, decrease the number of rings .

To change the number of rings of the reserve telephone in the *TEL/FAX* mode, proceed as follows:

1

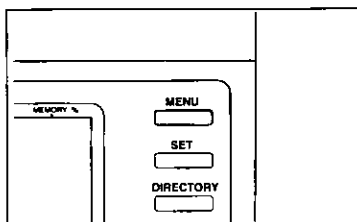

Press **MENU** until the following is shown.

PROG. [1.DATE 2.TEL  
3.SYSTEM 4.REPORT]

2

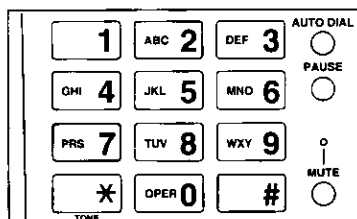

Press #, then press 27 to start programming.

The display shows the current setting.

TEL/FAX DELAYED  
RING=1 [1-4]

3

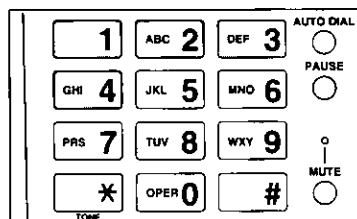

Enter the desired number of rings from 1 up to 4.



4

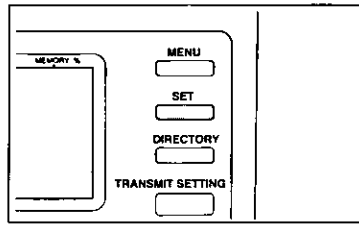

Press **SET** to store your selection into memory.

PROG. [1.DATE 2.TEL  
3.SYSTEM 4.REPORT]

5

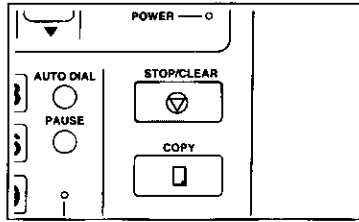

Press **STOP/CLEAR** to end the operation.

4

# Setting the Transmission Speed

The unit automatically selects the optimum transmitting speed, depending on the line condition and the type of the other facsimile unit. But, if problems such as transmission errors caused by poor line condition frequently occur, lower the speed manually by one rank.

The following transmission speeds are available:

- High:** 9600 bits per second (pre-selected setting).
- Middle high:** 7200 bits per second.
- Middle low:** 4800 bits per second.
- Low:** 2400 bits per second.

1

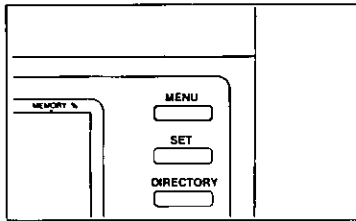

Press **MENU** until the following is shown.

```

PROG. [1.DATE 2.TEL
3.SYSTEM 4.REPORT]
    
```

2

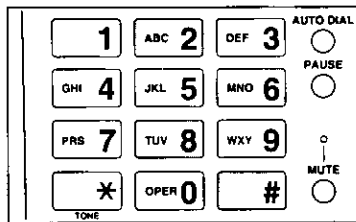

Press #, then press **28** to start programming.

```

TX SPEED=9600BPS[A]
[1.A 2.B 3.C 4.D]
    
```

3

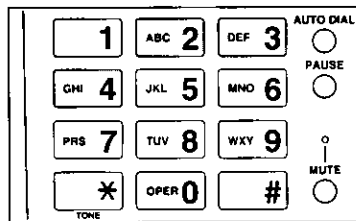

Enter the number of the selection you desire.

Setting selections:

- 1: A (9600 BPS)
- 2: B (7200 BPS)
- 3: C (4800 BPS)
- 4: D (2400 BPS)

4

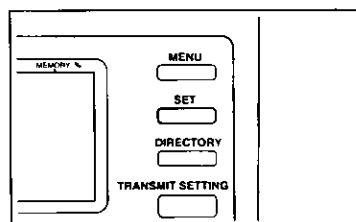

Press **SET** to store your selection into memory.

```

PROG. [1.DATE 2.TEL
3.SYSTEM 4.REPORT]
    
```

5

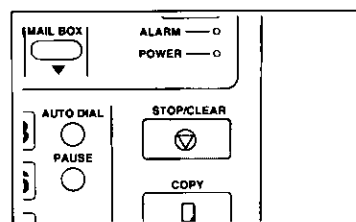

Press **STOP/CLEAR** to end the operation.

# Setting the Message Alert

When the received documents are stored into memory, the unit will alert you if the documents have been stored. When you hear slow beeps, clear the printing trouble or supply paper to print documents. The beep sound will stop.

This feature is activated as a pre-selected setting.  
To change the setting, proceed as follows:

1

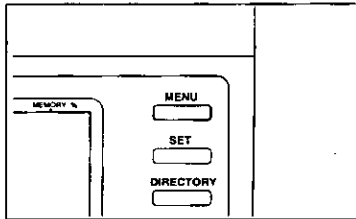

Press **MENU** until the following is shown.

```

PROG. [1.DATE 2.TEL
3.SYSTEM 4.REPORT]
    
```

2

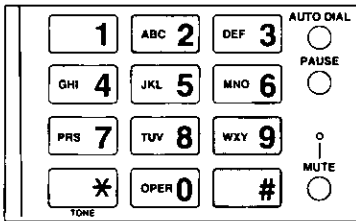

Press **#**, then press **29** to start programming.

```

MESSAGE ALERT
=ON [1.ON 2.OFF]
    
```

3

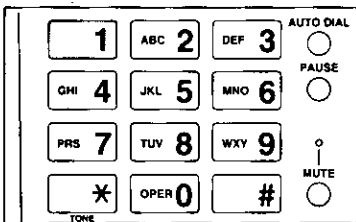

Press **2** to de-activate this feature.

```

MESSAGE ALERT
=OFF [1.ON 2.OFF]
    
```

– Press **1** to activate this feature.

4

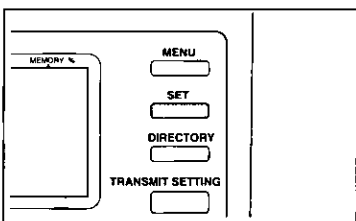

Press **SET** to store your selection into memory.

```

PROG. [1.DATE 2.TEL
3.SYSTEM 4.REPORT]
    
```

5

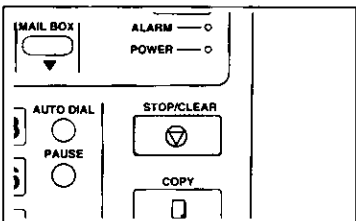

Press **STOP/CLEAR** to end the operation.

4

# Resetting the System Programming Features

Use this feature to return the basic features (#04 to #09) and the advanced features to their initial settings (see pages 40 to 42). The basic features #01 to #03 will still remain programmed even after activating this feature.

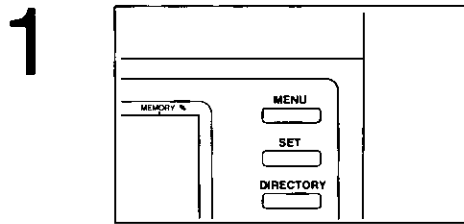

Press **MENU** until the following is shown.

```

PROG. [1.DATE 2.TEL
3.SYSTEM 4.REPORT]
    
```

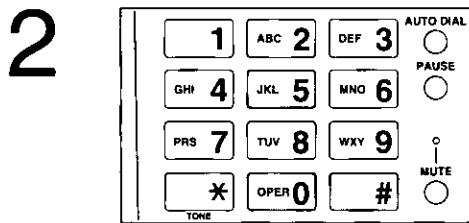

Press #, then press **50** to start programming.

```

SET DEFAULT
=NO      [1.YES 2.NO]
    
```

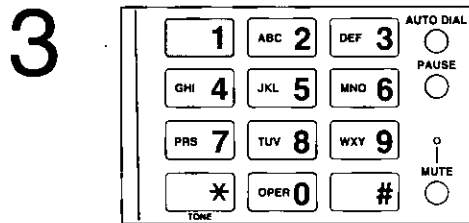

Press **1** to activate this feature.

```

SET DEFAULT
=YES     [1.YES 2.NO]
    
```

- To cancel this feature, press **2**.

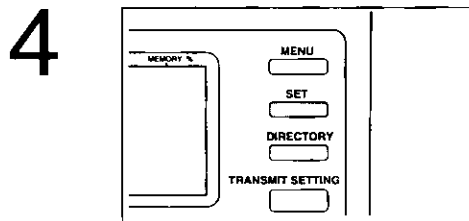

Press **SET** to store your selection into memory.

```

PARAMETER RESET OK?
=NO      [1.YES 2.NO]
    
```

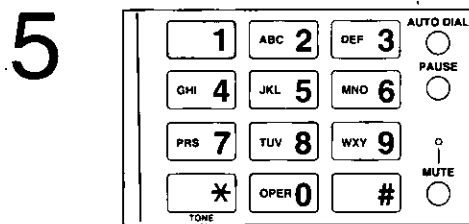

Press **1** to activate this feature.

```

PARAMETER RESET OK?
=YES     [1.YES 2.NO]
    
```

- To cancel this feature, press **2**.

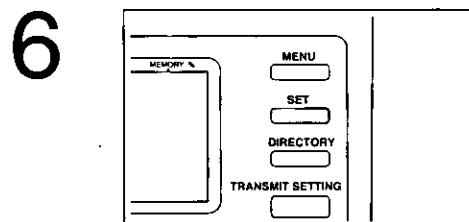

Press **SET** to start resetting.

```

DEFAULT SETTING
COMPLETED!
    
```

7

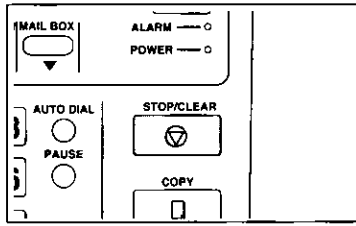

Press **STOP/CLEAR** to end the operation.

4

# Printing the System Programming List

By printing out the list, you can confirm the current settings of the basic and advanced features. To print out, see page 189.

## Sample of the system programming list:

```

***** < SYSTEM SET UP LIST > *****
*
*   << BASIC FEATURE LIST >>
*   #01 SET DATE                = Aug. 10 1994 09:40PM
*   #02 YOUR LOGO (I.E. COMPANY OR INDIVIDUAL NAME)
*   = ABC Ltd.
*   #03 YOUR TELEPHONE NUMBER   = 0123 456 7890
*   #04 PRINT TRANSMISSION REPORT = ERROR [1=ERROR 2=ON 3=OFF]
*   #05 MEMORY XMT              = OFF [1=ON 2=OFF]
*   #06 FAX RING COUNT          = 1 [1...4]
*   #07 ANS/FAX RING COUNT      = 1 [1...4 0=TOLL SAUER *=RINGER OFF]
*   #08 REMOTE ANS ID           = 111
*   #09 RECORDING TIME FOR ANS  = VOX [1=VOX 2=1MIN]
*
*
*   << ADVANCED FEATURE LIST >>
*   #10 LOGO POSITION             = OUT [1=OUT 2=IN]
*   #11 JOURNAL AUTO PRINT      = AUTO [1=AUTO 2=MANUAL]
*   #12 NETWORK PASSCODE       = 0000
*   #13 TX PASSCODE CHECK       = OFF [1=ON 2=OFF]
*   #14 RX PASSCODE CHECK       = OFF [1=ON 2=OFF]
*   #15 POLLING PASSCODE        = 0000
*   #16 SILENT FAX RECOGNITION RING = 3 [3...8]
*   #17 REMOTE FAX ACTIVATION CODE = **
*   #18 ENTER MESSAGE D
*   A = *** CONFIDENTIAL ***
*   B = *** URGENT REPLY REQUEST ***
*   C = *** URGENT PLEASE READ ***
*   D =
*
*   #19 COPY MODE               = REDUCTION [1=REDUCTION 2=INHIBITION 3=EXTEND]
*   #20 RX REDUCTION            = REDUCTION2 [1=REDUCTION1 2=REDUCTION2 3=INHIBITION]
*   #21 FAX FORWARDING          = OFF [FAX NO. = ]
*   #23 RING PATTERN DETECTION  = OFF [1=A 2=B 3=C 4=D 5=OFF]
*   #24 LCD CONTRAST            = NORMAL [1=LIGHT 2=NORMAL 3=DARKER]
*   #25 PRIVACY RING ID        = 333
*   #26 DAY/NIGHT MODE
*   DAY MODE TIME              = 12:00AM
*   NIGHT MODE TIME            = 12:00AM
*   #27 TEL/FAX DELAYED RING    = 1 [1...4]
*   #28 TX SPEED                = 9600BPS(A) [1=A 2=B 3=C 4=D]
*   #29 MESSAGE ALERT          = ON [1=ON 2=OFF]
*   #30 SET DEFAULT             = NO
*   #9000* (SERVICE DATA SET UP )
*
*   << DELAYED XMT >>
*   DELAYED MODE               = OFF
*   MEMORY XMT                 = ON
*   PHONE NUMBER                =
*   START TIME                  = 12:00AM
*   PAGE COUNTER                = 0
*   MESSAGE OUT                 = OFF
*****

```

### NOTE:

– The program number “#9000\*” is only for service personnel.  
To print the system programming list, proceed as follows:

To print the system programming list, proceed as follows:

1

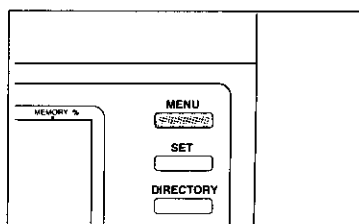

Press **MENU** until the following is shown.

PROG. [1.DATE 2.TEL  
3.SYSTEM 4.REPORT]

2

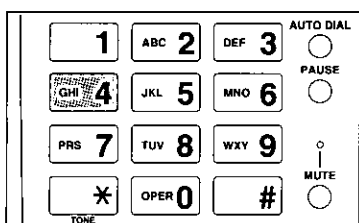

Press **4** to start programming.

SELECT NO. [1.SYSTEM  
2.TEL NO. 3.JOURNAL]

3

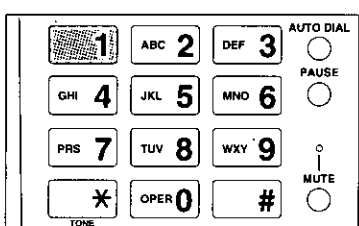

Press **1** to print the list.

The unit starts printing.

PRINTING  
SYSTEM LIST

– To interrupt printing, press **STOP/CLEAR** before the unit feeds the paper.

4

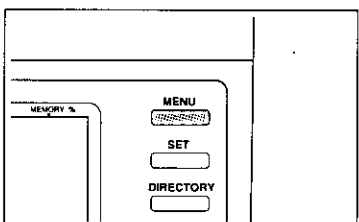

After printing, press **MENU** to end the operation.

4





# ***Chapter 5***

## ***Troubleshooting and Maintenance***

## Error display messages

DISPLAY MESSAGE	CAUSE & SOLUTION
JAN 1 12:00AM 00 00 CALL SERVICE E12345	<ul style="list-style-type: none"><li>• Printing system is abnormal. Open and close the cartridge compartment cover. If this message still appears, service call will be required. See page 240.</li></ul>
JAN 1 12:00AM 00 00 ... CHANGE DRUM ...	<ul style="list-style-type: none"><li>• The drum unit has reached its life expectancy. Replace it with a new one. See page 216.</li><li>• Once this message has been displayed, the unit can print approximately 50 more pages.</li></ul>
JAN 1 12:00AM -- 00 CHARGING BATTERY	<ul style="list-style-type: none"><li>• No battery is installed. Install the battery. See page 28.</li><li>• The battery is being charged. Wait for about 5 hours.</li><li>• Battery power is low. Replace the battery with a new one. See page 218.</li></ul>
JAN 1 12:00AM 00 00 .. CHECK DOCUMENT ..	<ul style="list-style-type: none"><li>• The document has not been fed into the unit properly, or the document is electrostatically charged. Re-insert the document. If the misfeeding happens frequently, adjust the feed pressure in the document feeder unit. See page 201.</li></ul>
JAN 1 12:00AM 00 00 ... CHECK DOOR ...	<ul style="list-style-type: none"><li>• The cartridge compartment cover is open. Close it.</li></ul>
JAN 1 12:00AM 00 00 CHECK DOOR OR DRUM	<ul style="list-style-type: none"><li>• The printer cover is open. Close it.</li><li>• The drum unit is not installed properly. Check it and re-install. See page 22 or 216.</li></ul>
JAN 1 12:00AM 00 00 CHECK FAX FORWARDING	<ul style="list-style-type: none"><li>• Documents that could not be forwarded remain in memory. Retrieve them by pressing the MENU button and then the SET button. See page 131.</li></ul>
JAN 1 12:00AM 00 00 ... CHECK MEMORY ...	<ul style="list-style-type: none"><li>• Memory (the stored phone numbers, parameters, etc.) has been erased. Re-program them.</li></ul>
CHECK PAPER SIZE PRESS MENU KEY	<ul style="list-style-type: none"><li>• The unit has been set to print on legal-size paper but letter size paper has been installed in the paper cassette. Replace the paper in the cassette with legal-size paper, then press the MENU button and then the SET button to print. If you change the paper size setting by pressing the LEGAL PAPER SUPPLY button, the first page in memory will not be printed.</li></ul>
CHECK PAPER SIZE PRESS STOP/CLEAR	<ul style="list-style-type: none"><li>• The unit has been set to print on legal-size paper but letter-size paper has been installed in the paper cassette. Replace the paper in the cassette with legal-size paper or change the paper size setting by pressing the LEGAL PAPER SUPPLY button, then press the STOP/CLEAR button and then try again.</li></ul>

## DISPLAY MESSAGE

## CAUSE & SOLUTION

```
JAN 1 12:00AM 00 00
.. DRUM LIFE OVER ..
```

- The drum unit is completely worn out. Replace it with a new one. See page 216.

```
DUE TO POWER OFF
DELAYED MODE ABORTED
```

- The programmed delayed transmission has been cleared due to a power failure or because the power switch has been turned off. Re-program it and try again. See page 103.

```
INSERT DOCUMENT
FACE DOWN
```

- No document is set in the document feeder tray. Insert document properly.

```
JAN 1 12:00AM 00 99
... MEMORY FULL ...
```

- When performing multistation or memory transmission, the document is too large and exceeds the memory capacity of the unit. Transmit the entire document at a later time or cancel memory transmission (see page 115) and transmit the entire document by using manual or automatic transmission.

- The memory is full of received documents that have been stored in memory due to a lack of recording paper or a recording paper jam. Supply paper to the cassette or clear the jam to print the documents. See page 25 or 202.

```
JAN 1 12:00AM 99 00
... MESSAGE FULL ...
```

- There is no room left in memory to record a message. Erase some or all messages. See page 72.

```
JAN 1 12:00AM 00 00
... NO RESPONSE ...
```

- The other party did not answer your call. Check the telephone number and then try again.

```
JAN 1 12:00AM 00 00
... OUT OF PAPER ...
```

- The unit has run out of recording paper. Supply paper. See page 25.
- The paper cassette is not installed properly. Check it and re-install. See page 25.

```
JAN 1 12:00AM 00 00
. PAPER JAM 1 .
```

- The recording paper is jammed in the paper feed area. Remove the paper causing the problem. See page 203.

```
JAN 1 12:00AM 00 00
. PAPER JAM 2 .
```

- The recording paper is jammed in the paper transfer area or the fuser area. Remove the paper causing the problem. See page 203.

```
JAN 1 12:00AM 00 00
. PAPER JAM 3 .
```

- The recording paper is jammed in the paper ejection area. Remove the paper causing the problem. See page 205.



## DISPLAY MESSAGE

## CAUSE & SOLUTION

```
JAN 1 12:00AM 00 00
** POLLING ERROR **
```

```
JAN 1 12:00AM 00 00
RECORD ANS-GREETING
```

```
JAN 1 12:00AM 00 00
RECORD TEL-GREETING
```

```
JAN 1 12:00AM 00 00
REDIAL TIME OUT
```

```
JAN 1 12:00AM 00 00
* REMOVE DOCUMENT *
```

```
JAN 1 12:00AM 00 00
*** SUPPLY TONER ***
```

```
JAN 1 12:00AM 06 00
TIME LEFT = 0m30s
```

```
JAN 1 12:00AM 00 00
*** TONER EMPTY ***
```

```
JAN 1 12:00AM 00 00
.. TRANSMIT ERROR ..
```

```
JAN 1 12:00AM 00 00
WAITING TO PRINT
```

```
JAN 1 12:00AM -- 00
*** WARM UP ***
```

- The polling passcode does not match. Check the other party and set the same passcode as the other unit. See page 110.  
Note that polling by using the passcode is effective between the compatible machines.
- The other unit does not provide the polled function. Check the other party.
- The greeting message for the *ANS/FAX* mode is not recorded. Record your greeting message. See page 34.
- The greeting message for the *TEL/FAX* mode is not recorded. Record your greeting message. See page 34.
- The automatic redialing was not successful due to a busy line or no answer from the other party. Try again.
- A document is jammed. Open the upper cover and remove the document causing the problem. See page 202.
- The unit attempted to transmit a document longer than 660 mm (26"). Press the STOP/CLEAR button and remove the document. Divide it into two or more pages, and try again.
- Toner supply is low. Replace the toner cartridge with a new one. See page 210.  
Once this message has been displayed, the unit can print approximately 50 more pages.
- If the remaining time for recording messages is little, erase useless messages from memory. See page 72.
- Toner supply is completely consumed. Replace the toner cartridge with a new one. See page 210.
- A transmission error has occurred. Try again.
- Your network passcode does not correspond to the other party's. Check the network passcode. See page 123.
- The polling passcode does not match. Check the other party and set the same passcode as the other unit. See page 110.  
Note that polling by using the passcode is effective between the compatible machines.
- The unit has run out of recording paper while printing. Supply paper. See page 25.
- The recording paper jammed while printing. Remove the paper causing the problem. See page 202.
- The printer is warming up. Wait until warm-up is completed.

## ***Explanation of communication result on the report***

When trouble occurs, the following messages may be printed on the transmission and journal reports. See pages 160 and 167.

<b>PRINTED MESSAGE</b>	<b>MEANING</b>
ABNORMAL TEMPERATURE	•An abnormal high or low temperature occurred.
COMMUNICATION ERROR	•Transmission or reception error occurred.
DOCUMENT JAMMED	•The document was jammed. Remove the document causing the problem. See page 200.
DRUM LIFE OVER	•The drum unit was completely worn out. Replace the drum unit. See page 216.
MEMORY FULL	•The document was not received due to memory full.
MULTI XMT CANCELED	•Multistation transmission was canceled by pressing the STOP/CLEAR button.
NO DOCUMENT	•The document was not fed into the unit properly.
NO RESPONSE	•The receiving unit was busy or out of recording paper.
PAPER OUT	•The unit was out of recording paper. Supply paper. See page 25.
PASSCODE FAILED	•The passcode communication failed. Check the other party and set the same passcode as the other unit. See pages 110 and 125.
POLLING ABORTED	•Polling was interrupted during the redialing.
PRESSED THE STOP KEY	•Fax communication was interrupted because the STOP/CLEAR button was pressed.
PRINTER PAPER JAM	•The recording paper was jammed. Remove the paper causing the problem. See page 202.
REDIAL TIME OUT	•Transmission was failed because the line was busy or there was no answer.
THE COVER WAS OPENED	•The printer cover was opened. Close the cover.
TONER DOOR WAS OPENED	•The cartridge compartment cover was open. Close the cover.
TONER EMPTY	•Toner supply was completely consumed. Replace the toner cartridge. See page 210.
XMT ABORTED	•Transmission was interrupted during the redialing.
OK	•Fax communication was successful.

## General corrective measures

### GENERAL

<b>PROBLEM</b>	<b>CAUSE &amp; SOLUTION</b>
<b>The unit does not operate properly.</b>	<ul style="list-style-type: none"><li>• Turn the power switch off, then turn it on again.</li><li>• Disconnect the unit from the telephone line and connect a known working phone. If the known working phone operates properly, call your service center to have the unit repaired. If the known working phone does not operate properly, consult your telephone company.</li></ul>
<b>Cannot transmit, receive a document, or talk.</b>	<ul style="list-style-type: none"><li>• Telephone line cord is connected incorrectly or not connected. Confirm the connection. See page 30.</li></ul>
<b>Cannot make a call.</b>	<ul style="list-style-type: none"><li>• Confirm your line condition and set the dialing mode selector properly. See page 32.</li></ul>
<b>The ALARM indicator light is on.</b>	<ul style="list-style-type: none"><li>• The printer cover or cartridge compartment cover is open. Close firmly.</li></ul>
<b>The unit does not ring.</b>	<ul style="list-style-type: none"><li>• The ringer volume selector is set in the OFF position. Set the ringer volume selector in the HIGH or LOW position. See page 32.</li><li>• ANS/FAX ring count is set to "RINGER OFF". Change the programming. See page 163.</li></ul>

### FAX TRANSMISSION

<b>PROBLEM</b>	<b>CAUSE &amp; SOLUTION</b>
<b>The ALARM indicator light flashes after transmission.</b>	<ul style="list-style-type: none"><li>• A transmission error has occurred. Try again.</li></ul>
<b>The ALARM indicator light is on during transmission.</b>	<ul style="list-style-type: none"><li>• A document more than 660 mm (26") is being transmitted. Divide the document into two or more pages, and try again.</li><li>• A document is jammed. Remove it, then try again. See page 200.</li><li>• The unit has received special tones for special telephone services, such as call waiting. Cancel such services, or connect the unit to a line that does not have such services.</li></ul>

**PROBLEM****CAUSE & SOLUTION**

**The other party complains that letters on their received document are distorted.**

- The unit has received special tones for special telephone services, such as call waiting. Cancel such services, or connect the unit to a line that does not have such services.
- A reserve telephone connected to the same line was picked up during transmission. Hang up the reserve telephone and try again.

**The other party complains that a dirty pattern or black or white lines appear on their received documents.**

- The glass and rollers inside the document feeder are dirty. Open the upper cover and clean them. See page 207.

**Problems when transmitting documents overseas by using the automatic transmission.**

- Set the overseas transmission mode to on, then try again. See page 134.
- Lower the transmission speed, then try again. See page 184.
- If you still fail in transmission, transmit with the manual transmission. See page 55.

**Misfeeding of documents occurs frequently.**

- The feed pressure in the document feeder unit is improper. Adjust the pressure. See page 201.

**FAX RECEPTION****PROBLEM****CAUSE & SOLUTION**

**The ALARM indicator light is on during receiving.**

- The recording paper is jammed. Remove it. See page 202.

**Received documents are not printed out and are stored into memory.**

- The unit ran out of recording paper. Supply paper to print out. See page 25.
- The paper cassette is not installed properly. Check it and re-install. See page 25.

**Unable to receive documents.**

- The unit ran out of recording paper, and the memory is full. Supply paper to print documents stored into memory. See page 25.
- The paper cassette is not installed properly, and the memory is full. Check it and re-install. See page 25.

(continued)



## FAX RECEPTION (Cont.)

<b>PROBLEM</b>	<b>CAUSE &amp; SOLUTION</b>
<b>Unable to receive documents automatically.</b>	<ul style="list-style-type: none"><li>•The receiving mode is set to the <i>TEL</i> mode. Operate the manual reception (see page 58) or set the receiving mode to the <i>ANS/FAX</i>, <i>TEL/FAX</i> or <i>FAX</i> mode. See page 37.</li><li>•The time to answer the call may be too long. Decrease the number of rings to answer. See pages 162, 163, 170 and 182.</li><li>•Your greeting message may be too long. Shorten the message (see pages 34 and 35) or ask the other party to send a document with manual operation. See page 65.</li></ul>
<b>Recorded image is faint and cannot be read.</b>	<ul style="list-style-type: none"><li>•The sender transmitted a faint document. Request the sender to transmit a clearer copy of the document.</li></ul>
<b>Received image is distorted.</b>	<ul style="list-style-type: none"><li>•The unit has received special tones for special telephone services, such as call waiting. Cancel such services, or connect the unit to a line that does not have such services.</li><li>•A reserve telephone connected to the same line was picked up during reception. Hang up the reserve telephone, and ask the sender to transmit the document again.</li></ul>
<b>A dirty pattern or black lines appear on the received documents.</b>	<ul style="list-style-type: none"><li>•The rollers inside the printer are dirty. Clean the rollers (see page 209).</li><li>•There are scratches on the drum unit. Replace the drum unit. See page 216.</li></ul>
<b>Paper jam occurs successively.</b>	<ul style="list-style-type: none"><li>•The selected paper size is different from the loaded paper's size. Select the correct paper size by pressing the LEGAL PAPER SUPPLY button. See page 39.</li></ul>
<b>Problems when receiving documents overseas.</b>	<ul style="list-style-type: none"><li>•Your greeting message may be too long. Shorten your greeting message to 10 seconds or less. See page 34 and 35.</li></ul>
<b>Unable to retrieve a document by using the polling function.</b>	<ul style="list-style-type: none"><li>•Your polling passcode does not correspond to that of the other unit. Program the correct passcode. See page 110.</li><li>•The other unit does not provide polled function. Check the other party, and try again.</li></ul>
<b>Unable to retrieve a document from the mail box.</b>	<ul style="list-style-type: none"><li>•The mail box passcode does not match. Make sure that you use mail box passcode correctly. See page 120.</li></ul>



## COPYING

PROBLEM	CAUSE & SOLUTION
The <b>ALARM</b> indicator light is on during copying.	<ul style="list-style-type: none"><li>•The recording paper is jammed. Remove it. See page 202.</li></ul>
A dirty pattern or black lines appear on the copied documents.	<ul style="list-style-type: none"><li>•The rollers inside the printer are dirty. Clean the rollers see page 209.</li><li>•There are scratches on the drum unit. Replace the drum unit. See page 216.</li></ul>
Misfeeding of documents occurs frequently.	<ul style="list-style-type: none"><li>•The feed pressure in the document feeder unit is improper. Adjust the pressure. See page 201.</li></ul>

## ANSWERING DEVISE

PROBLEM	CAUSE & SOLUTION
No voice-messages have been recorded in the <i>ANS/FAX</i> mode.	<ul style="list-style-type: none"><li>•The memory is full. Erase some or all messages. See page 72 or 142.</li></ul>
Memo message, telephone conversation and greeting message cannot be recorded. 6 beeps are heard.	<ul style="list-style-type: none"><li>•The memory is full. Erase some or all messages. See page 72 or 142.</li></ul>
When the voice message is played, the sound level is low or nothing can be heard.	<ul style="list-style-type: none"><li>•The speaker volume is low. Raise the sound level by using the volume control button. See page 69.</li></ul>
Unable to retrieve recorded messages from a remote phone.	<ul style="list-style-type: none"><li>•Make sure that you use your remote code correctly. When you dial the remote code, press the buttons firmly. See page 139.</li></ul>
Some voice-messages have not been fully recorded.	<ul style="list-style-type: none"><li>•The recording time is set to '1 minute'. You can select the recording time to "unlimited". See page 165.</li></ul>

## Clearing a document jam

If an original document becomes jammed in the document feeder unit, the alarm indicator will light and the display will show the following message:

```
AUG10 3:00PM 00 00  
- REMOVE DOCUMENT -
```

Remove the document causing the problem by proceeding as follows:

1

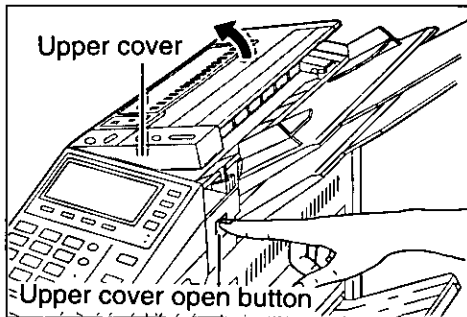

Open the upper cover by pushing the upper cover open button.

2

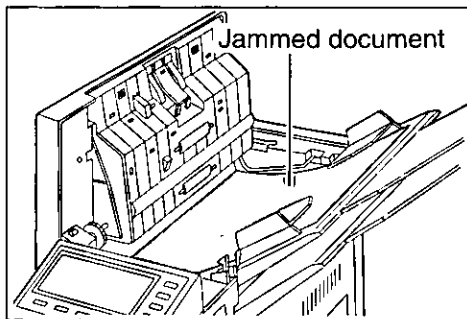

Remove the jammed document carefully.

3

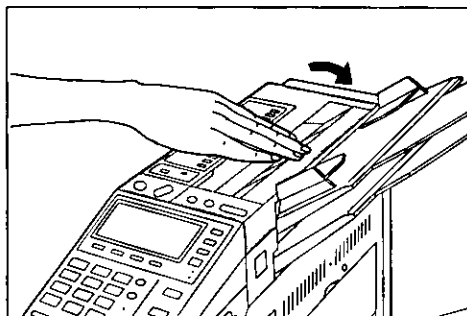

Close the upper cover carefully by pushing down the center of the cover until the cover locks into position.

## Adjusting the feed pressure

If misfeeding of documents, such as a multiple feed trouble or no feed trouble, occurs frequently, try to adjust the feed pressure in the document feeder unit by proceeding as follows:

1

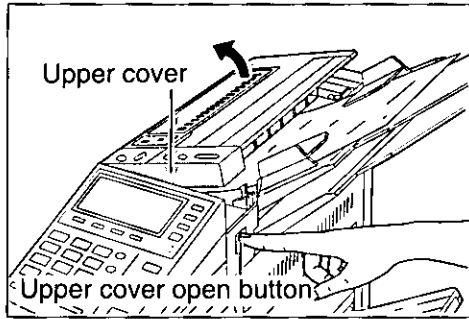

Open the upper cover by pushing the upper cover open button.

2

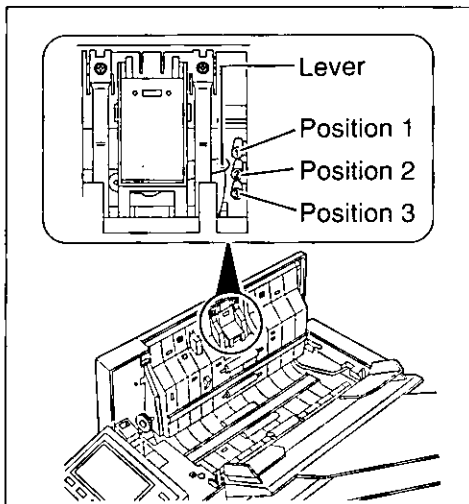

Shift the position of the lever on the document feeder unit by using an instrument with a pointed end, like a clip or ball-point pen.

- Position 1: The case of no feed trouble
- Position 2: Standard position
- Position 3: The case of multiple feed trouble

3

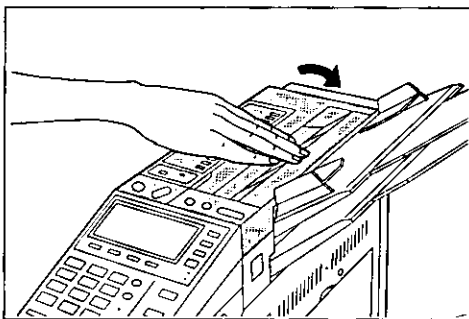

Close the upper cover carefully by pushing down the center of the cover until the cover locks into position.

## Clearing a recording paper jam

If a recording paper jam occurs inside the unit, the display will show one of the following messages. Check the relevant areas, and remove any jammed paper.

AUG10 3:00PM 00 00 · PAPER JAM 1 ·
---------------------------------------

.....Paper feed area. See page 203.

AUG10 3:00PM 00 00 · PAPER JAM 2 ·
---------------------------------------

.....Paper transfer area or fuser area. See page 203.

AUG10 3:00PM 00 00 · PAPER JAM 3 ·
---------------------------------------

.....Paper ejection area. See page 205.

### CAUTION:

– The fuser unit gets hot. Do not touch it.

### NOTE:

– If stains appear on the printed paper after a paper jam is cleared, it is recommended that you copy several pages as test printing.

### Paper Jam Areas:

<Cross section>

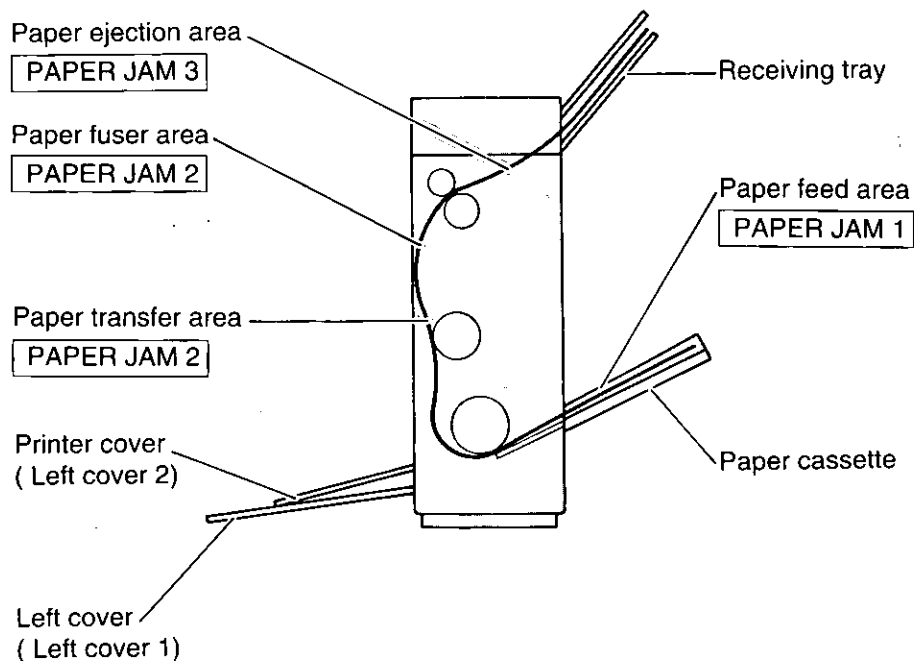

*Clearing a paper jam in the paper feed area:*

When the display shows the following message, proceed as follows:

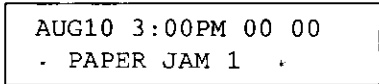

1

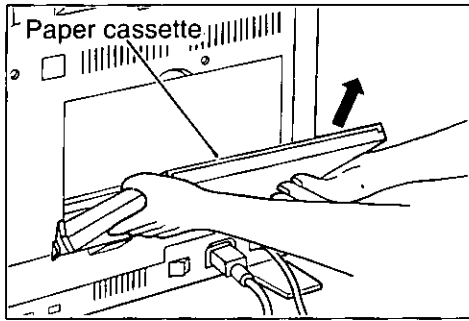

Remove the paper cassette from the unit.

2

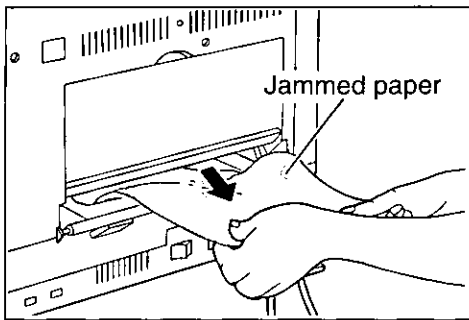

Remove the jammed paper, then re-install the paper cassette.

**NOTE:**

- After removing the jammed paper, open the left cover and then open and close the printer cover once to clear the error message.

*Clearing a paper jam in the paper transfer area or the fuser area:*

When the display shows the following message, proceed as follows:

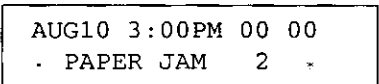

1

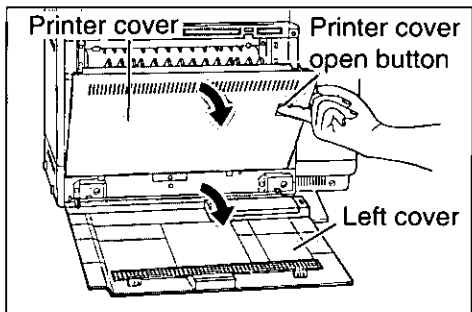

Open the left cover, and open the printer cover by pulling the printer cover open button.

(continued)

# 2

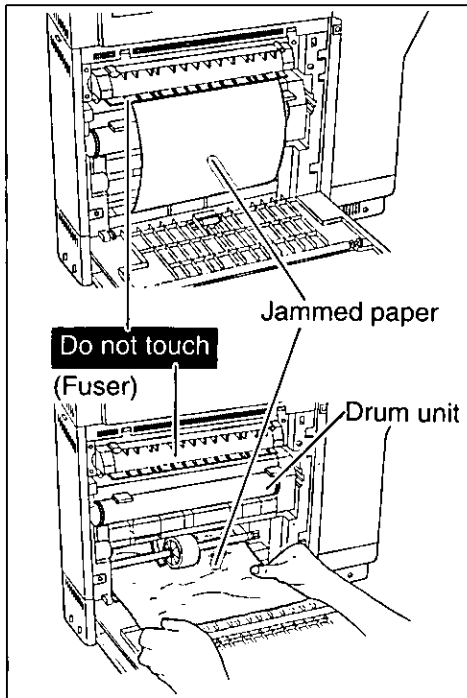

Remove the jammed paper.

**CAUTIONS:**

- The fuser gets hot. Do not touch it.
- Do not expose the drum unit to light for more than 5 minutes.
- Do not touch the green drum surface.
- If the jammed paper has toner on it, do not pull it out through the paper feed slot.
- Be sure that no paper fragments remain in the printer.

# 3

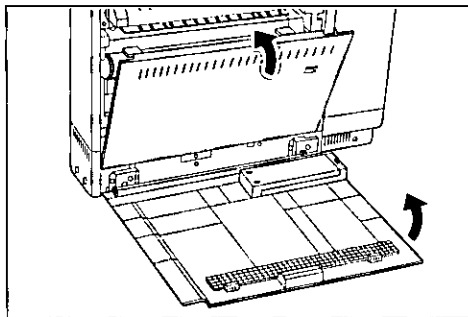

Close the printer cover and left cover.

**NOTE:**

- If a paper jam still occurs in the fuser area, after performing the above instructions, torn paper may remain in the printer unit. Check the inside of the printer unit.

## Clearing a paper jam in the paper ejection area:

When the display shows the following message, proceed as follows:

AUG10 3:00PM 00 00  
· PAPER JAM 3 ·

1

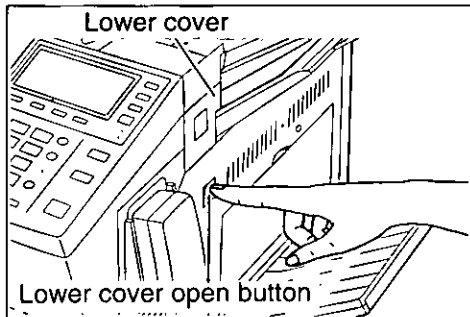

Push the lower cover open button, and open the lower cover completely until it clicks.

2

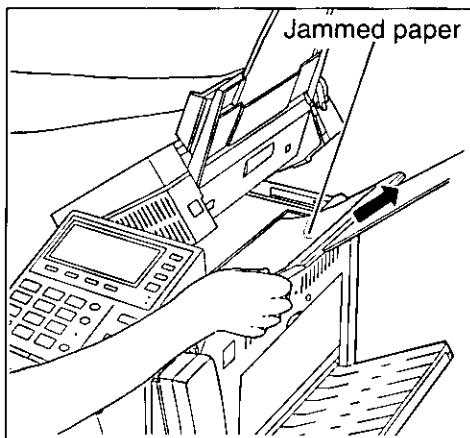

Remove the jammed paper by carefully pulling it up.

3

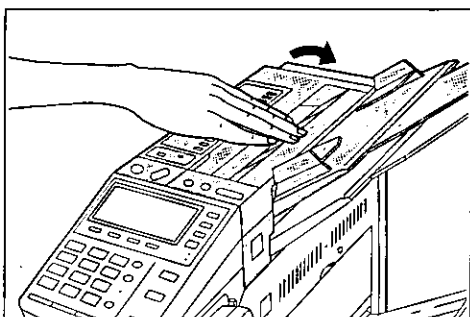

Close the lower cover carefully by pushing down the center of the cover until the cover locks into position.

### NOTE:

- If the jammed paper is not found in the paper ejection area, check the paper transfer area or the fuser area (see page 203).

## If a Power Failure Occurs...

---

This unit does not work when a power failure occurs. You cannot make and answer calls during a power failure. If a power failure occurs while transmitting or receiving documents, the transaction will be interrupted. The stored documents and voice-messages will remain in memory for about one day during the power failure, because of backup of the built-in battery.

**NOTE:**

– If a reserve phone is connected to the same line, use it during a power failure.

**CAUTION:**

– If the battery is not installed, the stored documents and voice-messages into memory will be lost.

### Power-down report

The power-down report will automatically print out after the power is restored. The report will not print out when there are no documents stored into memory.

**Sample of the power-down report:**

```
***** POWER DOWN REPORT *****
*
*                               POWER DOWN AT:      AUG. 10. 1994   4:23 PM
*
*                               RESTARTED AT:       AUG. 10. 1994   4:32 PM
*
*
*                               << WARNING >>
*                               CONTENTS HAVE BEEN CLEARED DUE TO POWER DOWN.
*
*
*                               No.   OTHER FACSIMILE   START TIME   TX PAGES   FUNCTION
*-----
*   01   9876543           11:45AM     02         DELAYED TRANSMISSION
*
*
*
*
*****
```

**NOTE:**

– When the fax forwarding feature is on, the power-down report will be transmitted to the forwarding station after the power is restored (see page 128).



# Maintenance

---

If there is a trouble on image quality, it will be required to clean the portions causing the trouble. Even if there is no trouble, periodic cleaning is recommended. The frequency of cleaning is depending on the environment.

Refer to below:

- We recommend that you clean the unit at least once a month.
- When a dirty pattern or black or white bands appear on a copied or transmitted document, clean the document feeder unit. See below.
- When the document is not fed properly, clean the document feeder unit. See below.
- When dark stripes or toner stains appear on printed paper, clean the printer. See page 209.

**CAUTION:**

- Turn the power off before performing any maintenance.

## *Cleaning the cabinet*

Use only a soft and dry cloth to clean the cabinet.

**CAUTION:**

- Do not use benzine, thinner, aerosol cleaners, or any abrasive powder to clean the cabinet.

## *Cleaning the document feeder unit*

Clean the inside of the document feeder unit by proceeding as follows;

- When a dirty pattern or black or white bands appear on a copied or transmitted document.
- When the document is not fed properly.

1

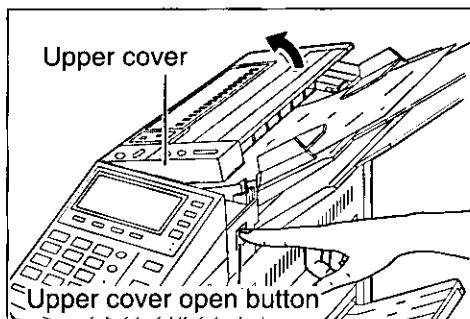

Open the upper cover by pushing the upper cover open button.

(continued)

2

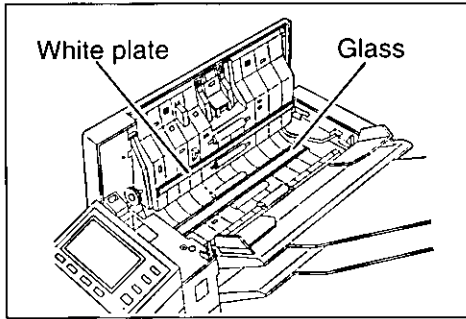

Wipe the glass and the white plate with a dry soft cloth.

3

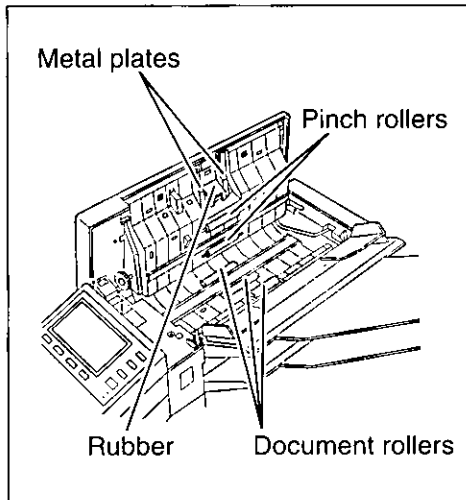

Clean the document rollers, pinch rollers, and rubber with a cloth moistened with isopropyl rubbing alcohol, then dry thoroughly to prevent paper from jamming.

**NOTES:**

- To prevent malfunction due to static electricity, do not use a dry cloth.
- Do not push the metal plates to avoid bending.

4

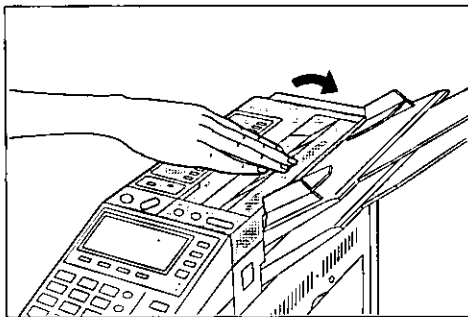

Close the upper cover carefully by pushing down the center of the cover until the cover locks into position.

## Cleaning the printer

If dark stripes or toner stains appear on printed pages, clean the inside of the printer by proceeding as follows:

1

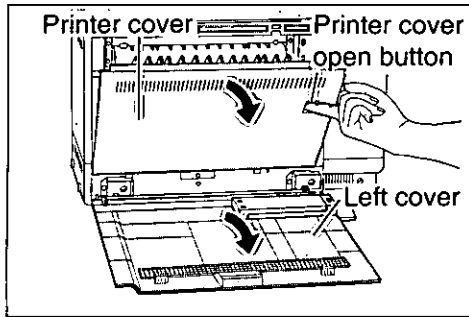

Open the left cover, and open the printer cover by pulling the printer cover open button.

2

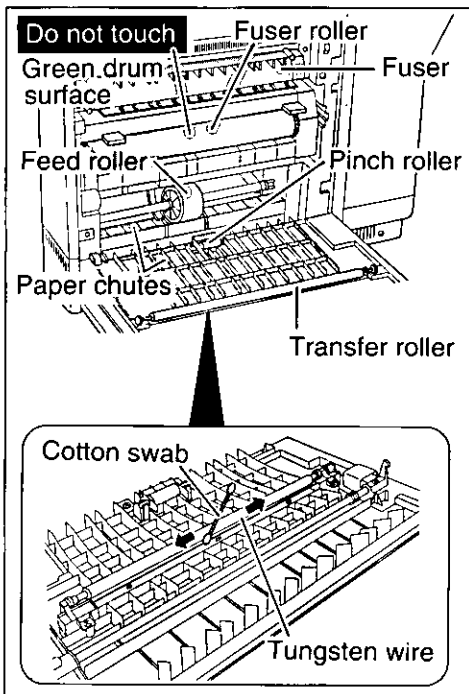

Clean the following areas with a dry soft cloth:

- Pinch roller
- Feed roller
- Transfer roller
- Paper chutes (paper dust)

Then, carefully wipe the tungsten wire by sliding a cotton swab from end to end 4 to 5 times.

### CAUTIONS:

- The unit must be turned off prior to cleaning.
- Do not clean the fuser with a stiff material. It may damage the fuser roller.
- Do not expose the drum unit to light for more than 5 minutes.
- Do not touch the green drum surface.

(continued)

5

# 3

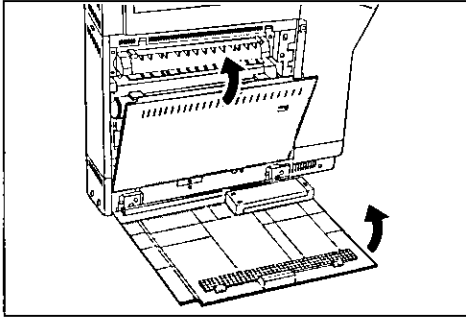

Close the printer cover and left cover firmly.

## ***Replacing the cleaning pad and the toner cartridge***

When the toner decreases to a level requiring replacement, the display will show the following message. Install a new toner kit (Part No. KX-A144), which contains a toner cartridge and a cleaning pad.

```
AUG10  3:00PM 00 00  
*** SUPPLY TONER ***
```

or

```
AUG10  3:00PM 00 00  
*** TONER EMPTY ***
```

### **CAUTION:**

- If ingestion of toner occurs, drink several glasses of water to dilute stomach contents, and seek immediate medical treatment. If eye contact with toner occurs, flush thoroughly with water, and seek medical treatment. If skin contact with toner occurs, wash thoroughly with soap and water.

### **NOTE:**

- Do not replace the toner cartridge until the above message is displayed.

To replace the cleaning pad and the toner cartridge, follow the instructions below.

1

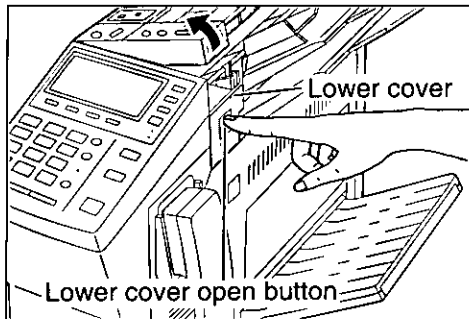

Push the lower cover open button, and open the lower cover completely until it clicks.

2

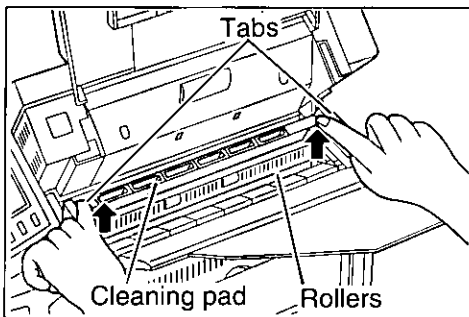

Remove the cleaning pad by lifting both tabs up.

**CAUTION:**

– Do not touch the rollers under the cleaning pad, because they may be hot.

3

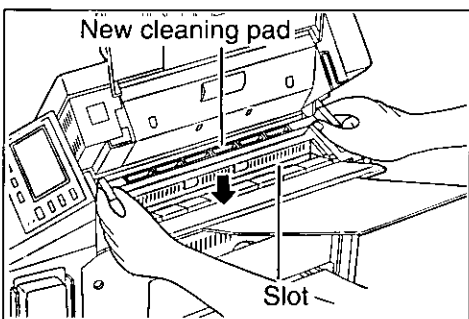

Insert the new cleaning pad into the slot by holding both side tabs.

4

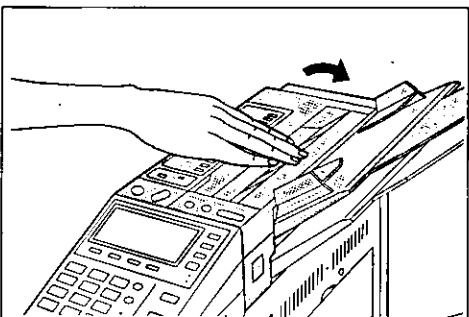

Close the lower cover carefully by pushing down the center of the cover until the cover locks into position.

(continued)

5

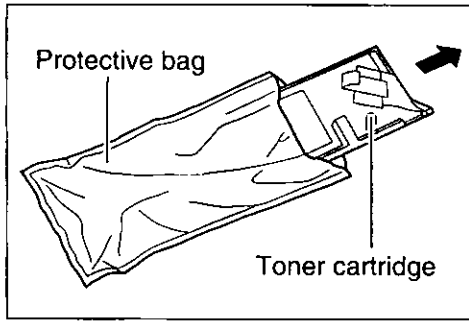

Open the protective bag and remove the toner cartridge.

6

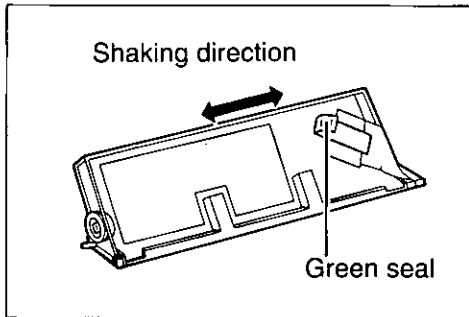

Gently shake the toner cartridge horizontally 4 to 5 times.

– This action distributes the toner evenly.

**NOTE:**

– Do not peel off the green seal until the installation is completed.

7

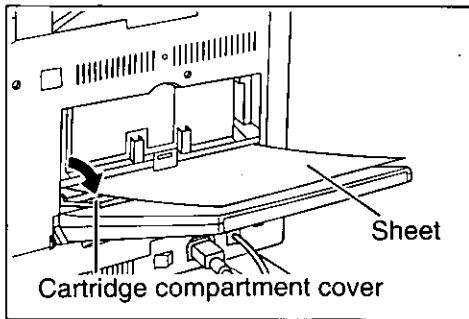

Open the cartridge compartment cover.

**CAUTION:**

– Place a useless sheet on the opened cartridge compartment cover in order to avoid getting dirty with the toner.

8

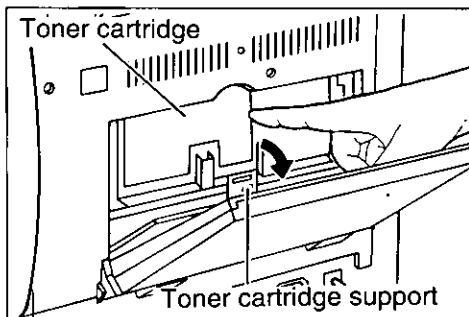

Tap the toner cartridge to empty toner and release the toner cartridge support.

9

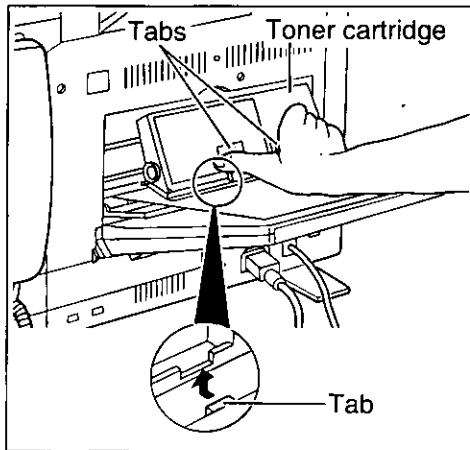

Remove the toner cartridge carefully by pushing both tabs firmly and raising it slightly.

**CAUTION:**

- Be careful not to spill any residual toner in removed toner cartridge.

10

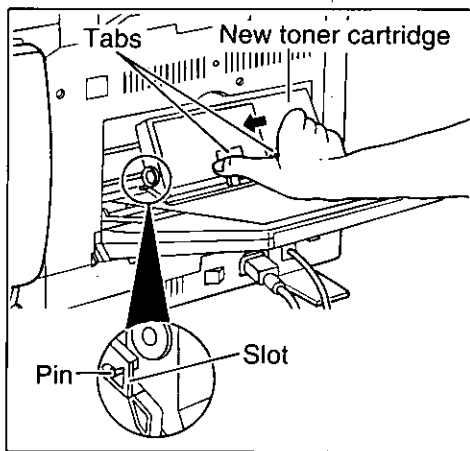

Install the new toner cartridge.

- Hold the tabs on the toner cartridge, and insert the side pins of the toner cartridge into the slots on the developer unit.

11

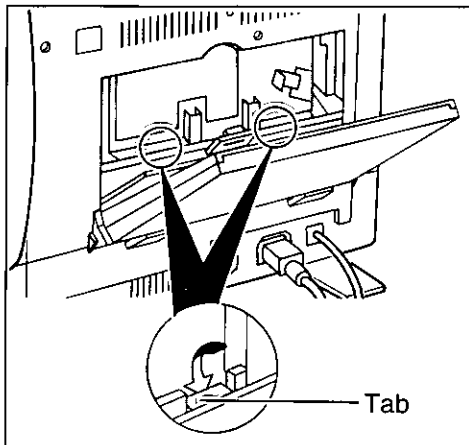

Press the toner cartridge down until it is caught by the tabs.

(continued)



12

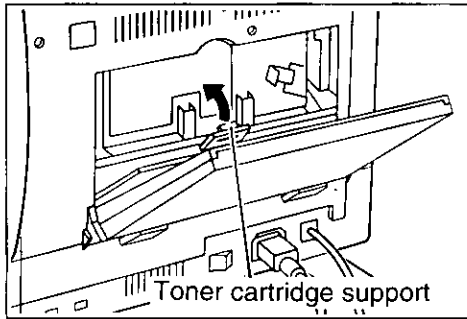

Close the toner cartridge support.

13

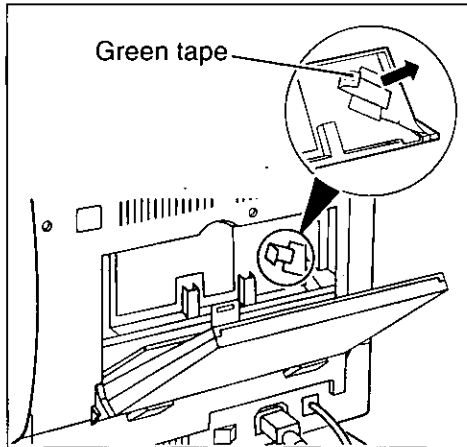

Peel off the green tape.

14

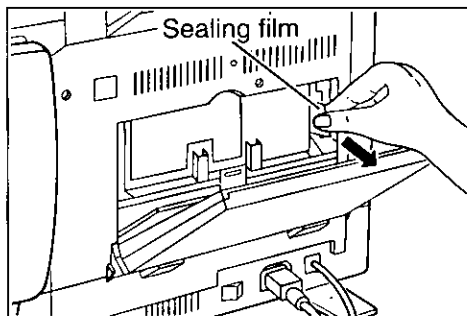

Hold the unit firmly, and completely remove the clear plastic sealing film by grasping it and pulling it outward .

**NOTES:**

- Do not twist the sealing film while pulling it, because toner may spill over.
- Be careful not to make the surrounding area dirty when handling the sealing film, because it may contain toner residue.

15

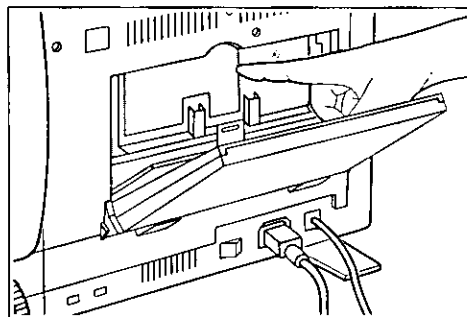

Tap the toner cartridge lightly to empty toner into the developer unit.



16

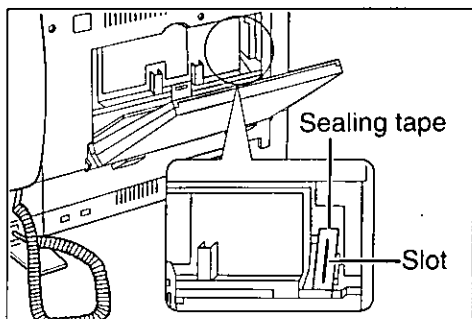

Put and fix the sealing tape to close the slot on the rear side of the toner cartridge.

– Use the provided sealing tape.

17

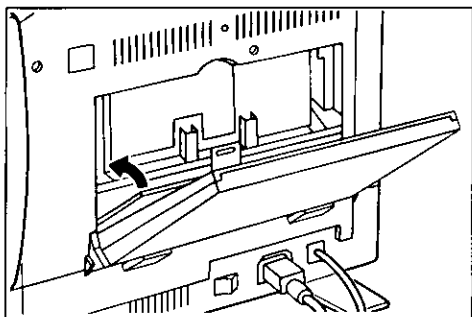

Remove the sheet on the cartridge compartment cover, and close the cover.

## Replacing the drum unit

When the drum unit is worn out, the display will show the following message. The unit will stop printing after approximately 50 pages. Replace the drum unit with a new one (Part No. KX-A145).

```
AUG10  3:00PM 00 00
... CHANGE DRUM ...
```

### CAUTION:

- The drum unit contains a photosensitive drum. Exposing it to light may damage the drum.
  - Do not expose the drum unit to light for more than 5 minutes.
  - Do not touch the green drum surface.
  - Do not keep the drum unit near dust or dirt.
  - Do not place the drum unit in a high humidity area.
  - Do not expose the drum unit to direct sunlight.

To replace the drum unit, follow the instructions below.

1

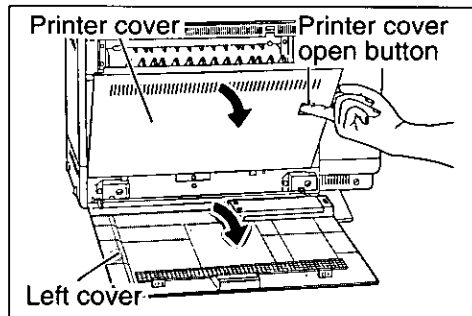

Open the left cover, and open the printer cover by pulling the printer cover open button.

2

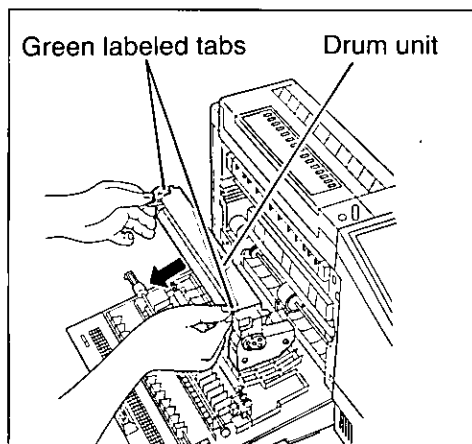

Remove the drum unit by slightly raising both green labeled tabs and pulling the drum unit outward.

3

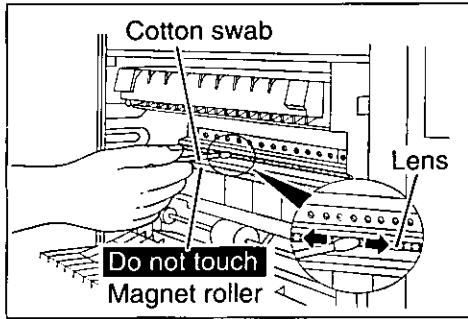

Wipe the lens by sliding the cotton swab from end to end 4 to 5 times.

– It is recommended to clean the inside of the printer (see page 209).

**CAUTION:**

– Do not touch the magnet roller.

4

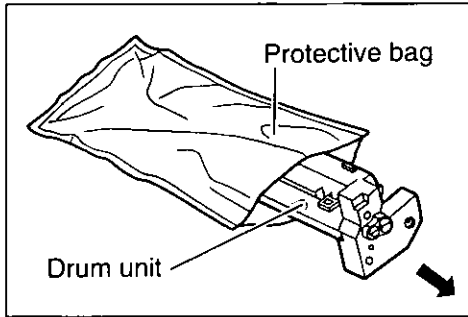

Open the protective bag by cutting the end of the bag and remove the drum unit.

5

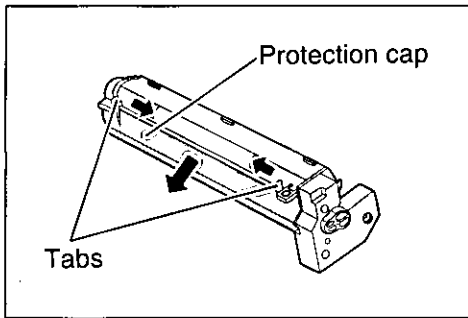

Remove the drum protection cap by pushing the right and left tabs inward.

**NOTES:**

- Do not touch the green drum surface under the protection cap as it may damage the drum unit.
- Keep the protection cap in the event that the unit must be repacked and transported.

6

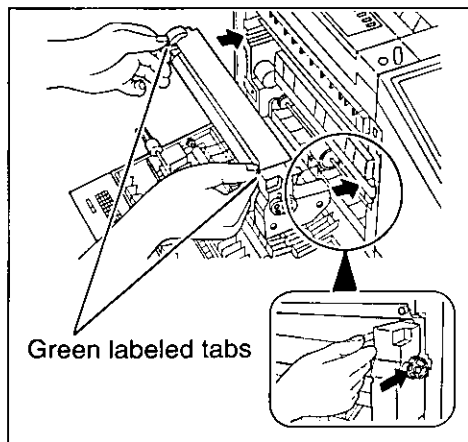

Install the new drum unit by holding the green labeled tabs and pushing it firmly into place.

(continued)

5

7

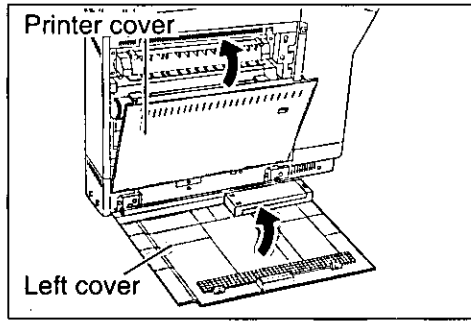

Close the printer cover and left cover firmly.

### Replacing the rechargeable battery

When the battery power is low, the display will show the following message. Replace the battery with a new one (Part No. KX-A67) if this message appears even when the battery has been charged for 5 hours.

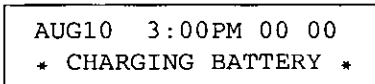

**CAUTION:**

- Confirm that there are no documents or voice-messages in memory, or they will be lost during the battery replacement.

To replace the battery, follow the instructions below.

1

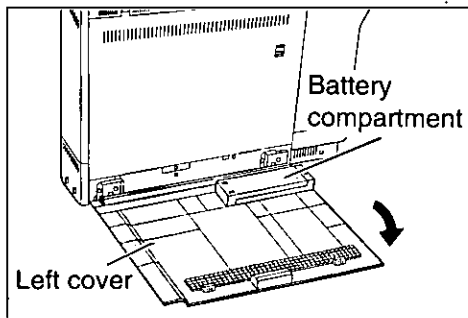

Open the left cover.

2

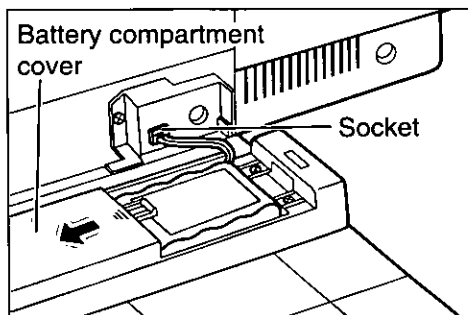

Remove the battery compartment cover by sliding and raising it slightly. Unplug the connector from the socket by pulling it out, and remove the battery.

3

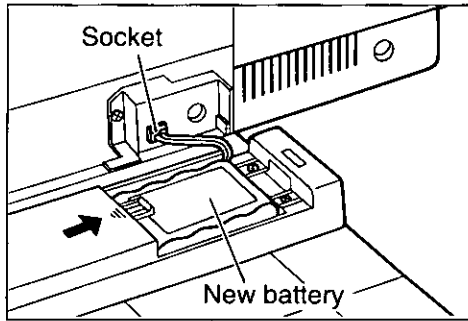

Place a new battery in the battery compartment and plug in. Then close the compartment cover.

4

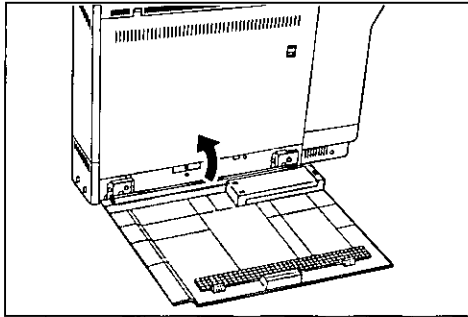

Close the left cover.

**CAUTION:**

– The battery is recyclable. At the end of its useful life, under various state and local laws, it may be illegal to dispose of this battery into the municipal waste stream. Check with your local solid waste officials for details in your area for recycling options or proper disposal.

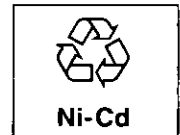

**NOTE:**

– Remember to charge the battery for 5 hours after battery replacement.

5

# Repacking

To transport or ship your unit, follow the instructions below.

- Disconnect the cords, cassette, and trays.
- Seal the toner cartridge.
- Repack the drum unit.
- Seal the inside of the printer.
- Pack into the original carton.

## NOTES:

- Use the original carton and all of the original packing materials.
- Improper repacking of the unit may result in a service charge to repair the unit or in a cleaning charge to remove spilled toner.
- Because the unit uses dry toner, extreme care must be taken when handling. The unit should be handled in the upright (vertical) position until the unit is repacked completely.

## Materials Required:

- Original carton and packing materials
- Dropcloth or newspaper
- Shipping tape
- Old clothing or clothing you do not mind getting dirty.

## Disconnecting the cords, cassette, and trays:

1

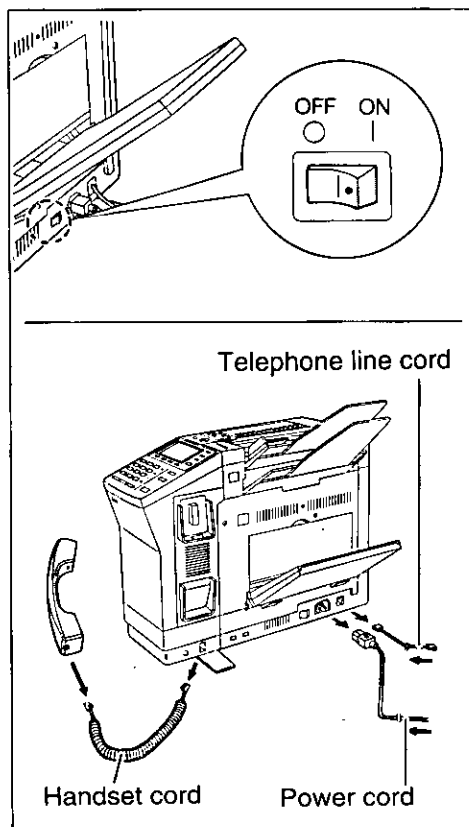

Turn the power off, then disconnect the power cord, telephone line cord, and handset cord.

- To disconnect the telephone line cord and handset cord, pull the plug while pressing the tab on it.

# 2

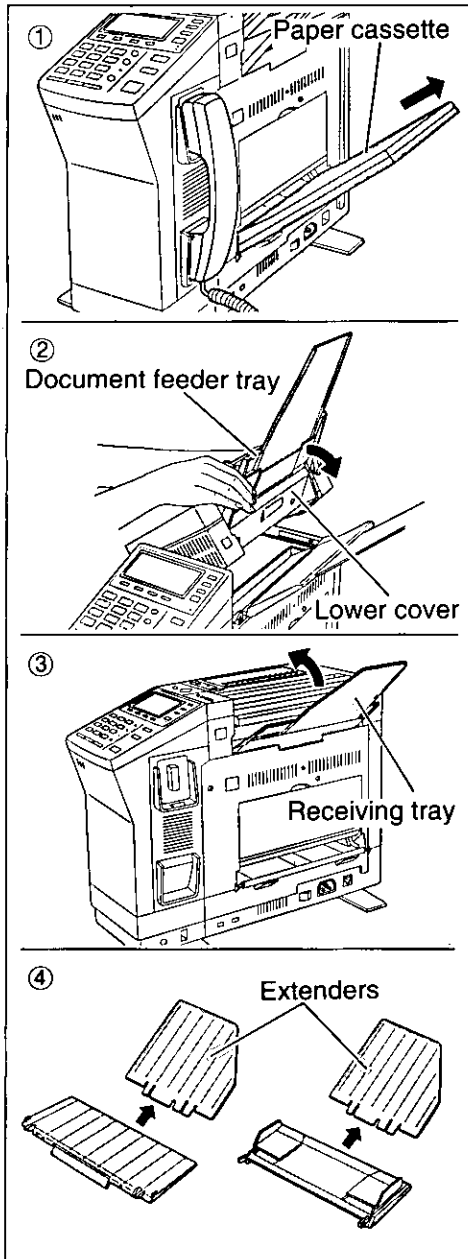

Remove the paper cassette, the receiving tray, and the document feeder tray by proceeding as follows:

① Pull the paper cassette outward with holding its both sides and remove it.

② Open the lower cover by pushing the lower cover open button. Then hold the lower cover, and push the document feeder tray downward and remove it, and close the lower cover.

③ Pull the receiving tray upward and remove it.

④ Remove the extenders from the receiving tray and the document feeder tray.

(continued)

*Sealing the toner cartridge:*

3

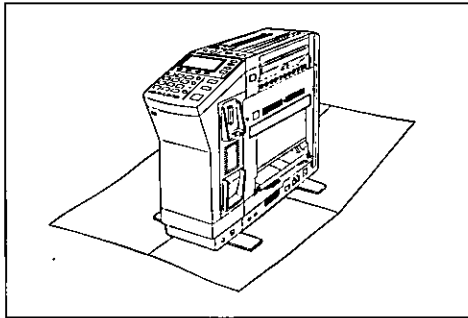

Spread a dropcloth or newspaper under the unit to keep the work area clean.

4

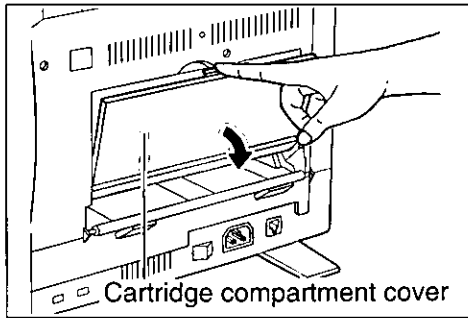

Open the cartridge compartment cover.

5

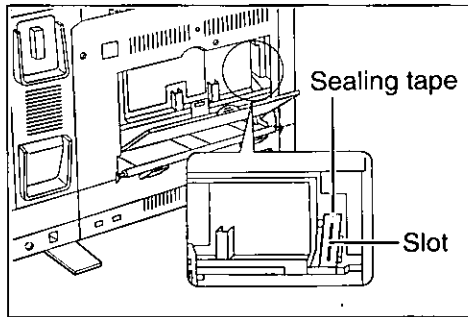

Put and fix the sealing tape to close the slot on the rear side of the toner cartridge if you have not covered the slot.

- Use the provided sealing tape.
- If toner spills around the slot, clean the area.

6

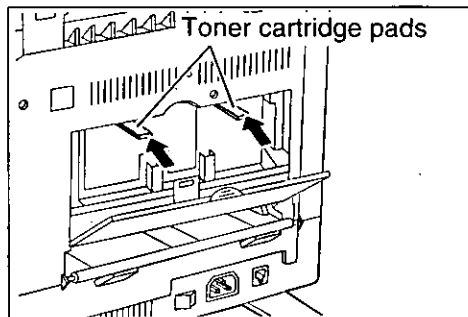

Install the toner cartridge pads.



7

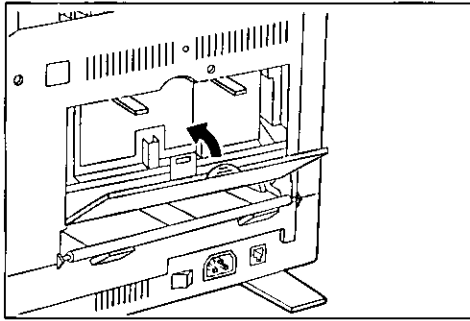

Close the cartridge compartment cover.

*Repacking the drum unit:*

8

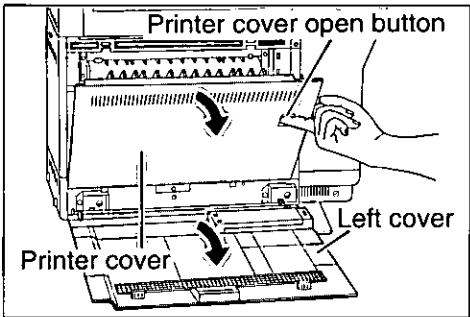

Open the left cover, and open the printer cover by pulling the printer cover open button.

9

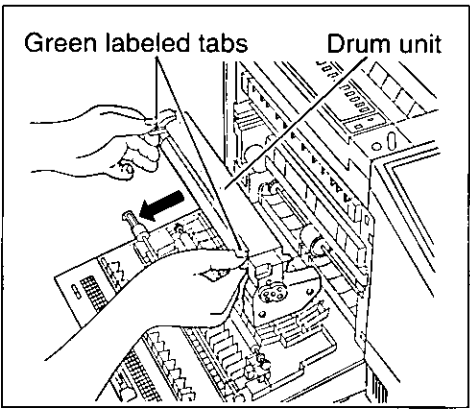

Remove the drum unit by slightly raising both green labeled tabs and pulling the drum unit outward.

**CAUTIONS:**

- Do not touch the green drum surface.
- Do not transport or ship the unit with the drum unit installed.

10

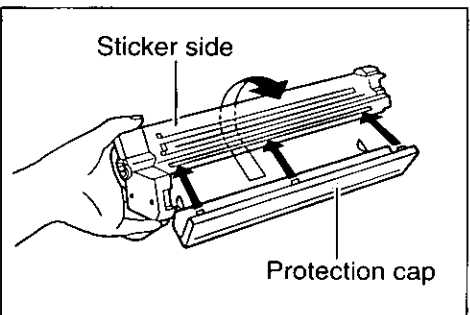

Replace the drum protection cap on the drum unit.

**NOTE:**

- Always place the drum unit with sticker side facing up, otherwise the printer may not be able to function properly.

(continued)

5

# 11

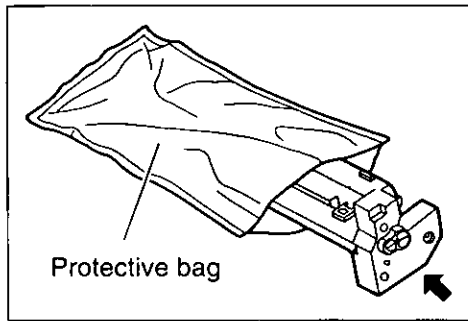

Pack the drum unit into the protective bag.

*Sealing the inside of the printer:*

# 12

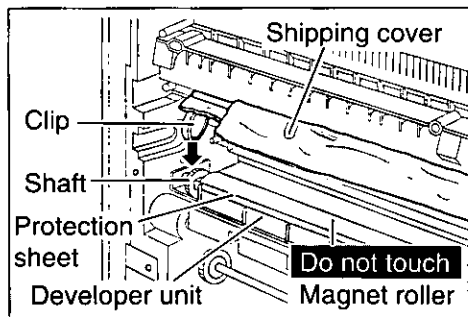

Hook the left clip of the shipping cover on the shaft of the developer unit, and press the clip firmly.

**CAUTIONS:**

- Do not touch the magnet roller.
- Make sure the protection sheet remains visible while installing the shipping cover.
- Be sure to install the shipping cover properly to avoid spilling toner.

# 13

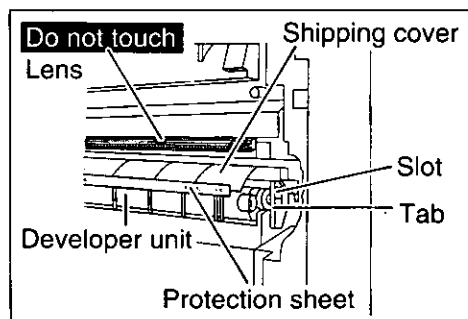

Press the right side of the shipping cover firmly, and insert the tab of the developer unit into the slot until it clicks into place.

**CAUTION:**

- Do not touch the lens.

14

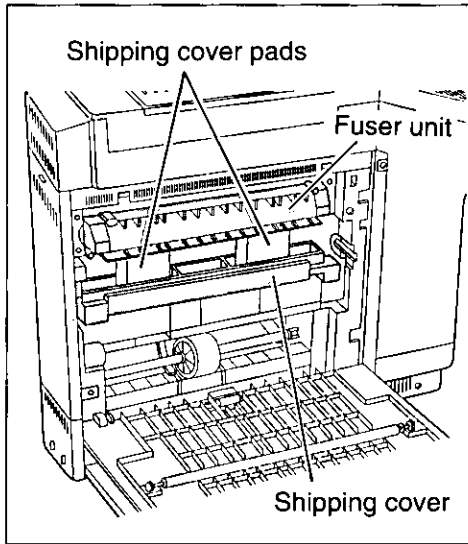

Install the shipping cover pads straight between the shipping cover and the fuser unit.

- The shipping cover pads should be placed in the cutouts on the shipping cover, corresponding to the green labels.

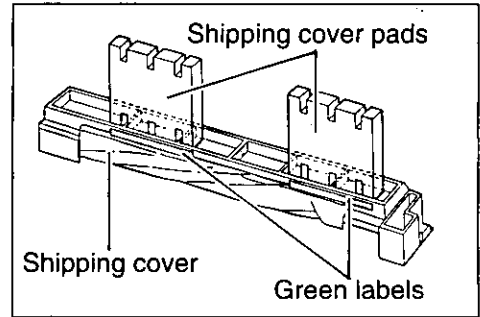

15

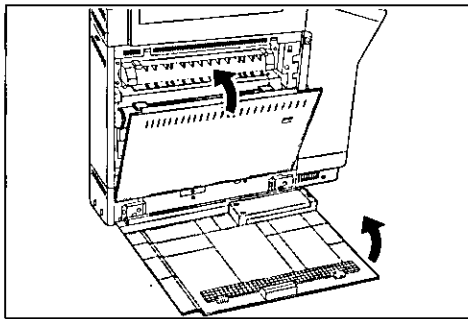

Close the printer cover and left cover firmly.

16

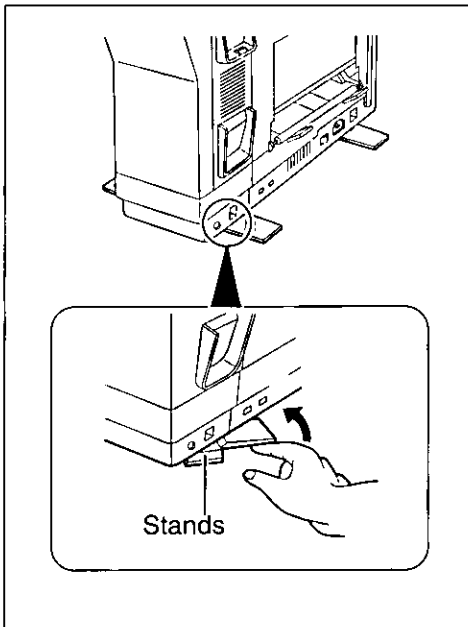

Place all the printer stands in their original positions.

(continued)

Repacking into the original carton:

# 17

- ① Wrap the unit in the packing sheet.
- ② Install the bottom cushion into the original carton box, and place the unit on it.
- ③ Place the right (R) and left (L) cushions on the unit.
- ④ Place the accessories shown below into the original accessory carton.
- ⑤ Place the accessory carton into the box.
- ⑥ Seal the box with plastic shipping tape.

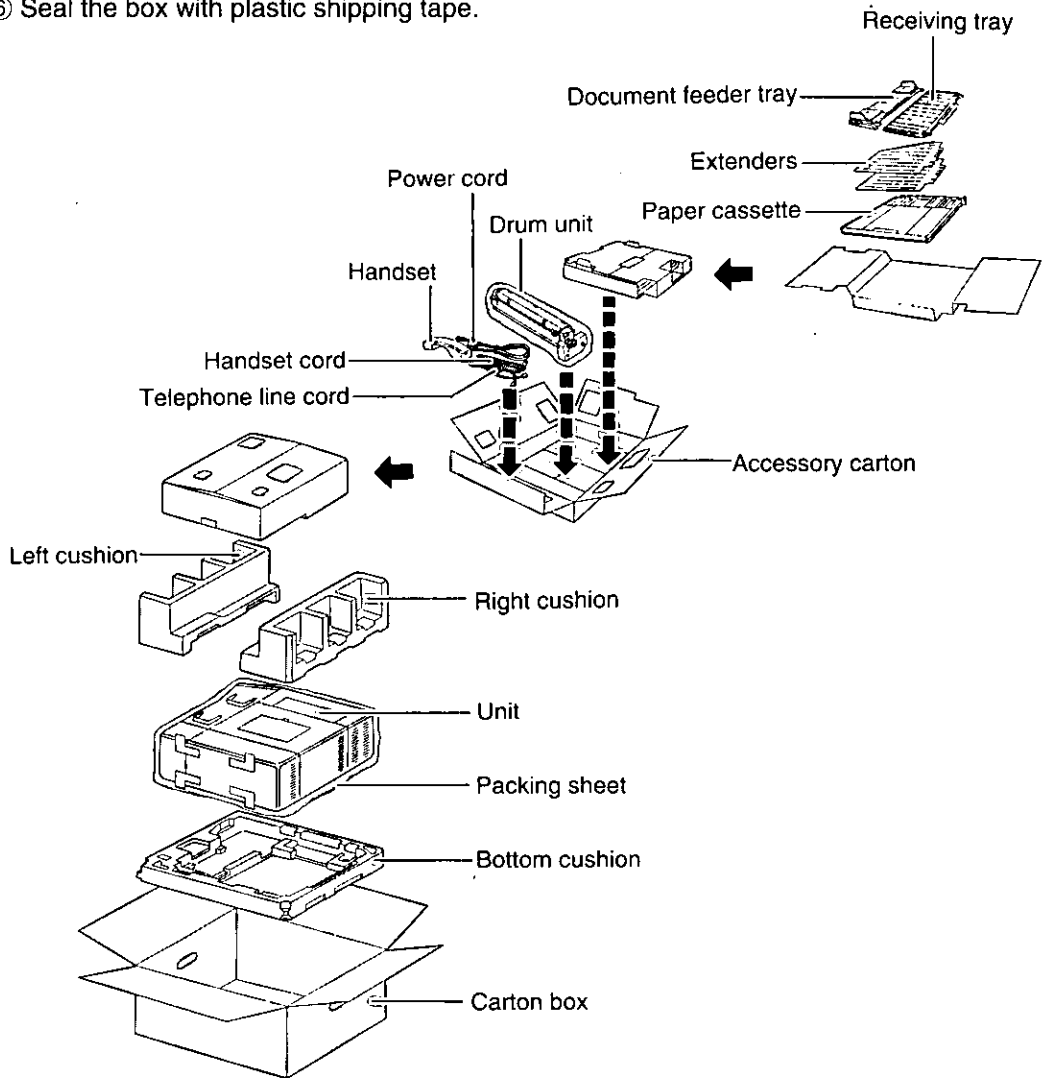

# **Chapter 6**

## *General Information*



## Accessory Order Information

---

Replacement parts and accessories are available through our local authorized parts distributors. See page 240.

Part No.	Description	Comment
KX-A144	Toner kit	Life: Approx. 1,600 pages average*  1 toner cartridge & 1 cleaning pad
KX-A145	Drum unit	Life: Approx. 6,000 pages average
KX-A67	Rechargeable battery	4.8V 600mAh

\* In case of 5% image area with multiple copying.

# Specifications

---

## Main unit specifications

Item No.	
1. <b>Applicable Lines:</b>	Public switched telephone network
2. <b>Compatibility:</b>	ITU-T G3
3. <b>Effective Scanning Width:</b>	Max. 208 mm ( $8\frac{3}{16}$ " )
4. <b>Recording Paper Size:</b>	Letter: 216 × 279 mm ( $8\frac{1}{2}$ " × 11") Legal: 216 × 356 mm ( $8\frac{1}{2}$ " × 14")
5. <b>Effective Printing Width:</b>	206 mm ( $8\frac{1}{8}$ " )
6. <b>Transmission Time*:</b>	Approx. 30 sec/page (G3 Normal mode, MH) Approx. 17 sec/page (G3 Original mode, MH) Approx. 15 sec/page (G3 Original mode, MR)
7. <b>Fax Redial Times:</b>	Up to 5 times
8. <b>Telephone Redial Times:</b>	Up to 15 times
9. <b>Scanning Density:</b>	Horizontal: 8 pels/mm (203 pels/inch) Vertical: 3.85 lines/mm (98 lines/inch) — Standard mode 7.7 lines/mm (196 lines/inch) — Fine or Halftone mode
10. <b>Scanner Type:</b>	Contact image sensor
11. <b>Printer Type:</b>	Electrophotographic LED array printer
12. <b>Data Compression System:</b>	Modified Huffman (MH), Modified READ (MR)
13. <b>Modem Speed:</b>	9600/7200/4800/2400 bps; Automatic Fallback
14. <b>Operating Environment:</b>	10 – 32.5°C (50 – 90.5°F) 20 – 80% RH
15. <b>Dimensions (H × W × D):</b>	371 × 148 × 489 mm ( $14\frac{5}{8}$ " × $5\frac{13}{16}$ " × $19\frac{1}{4}$ " )
16. <b>Mass (Weight):</b>	Approx. 12 kg (26.4 lb.)
17. <b>Power Consumption:</b>	Standby: 12 – 480 W Transmission: 17 – 490 W Reception: 12 – 480 W Copy: 24 – 500 W Maximum: 600 W
18. <b>Power Supply:</b>	120V AC, 60Hz

\*Transmission Time:

Transmission times apply to text data using ITU-T No. 1 test chart, between the same models at maximum modem speed and may vary in actual usage.

### NOTE:

– The specifications are subject to change without notice.

## ***Paper specifications***

<b>Item No.</b>	
1. <b>Basic Weight:</b>	60 – 120 g/m <sup>2</sup> (16 – 24 lb.)
2. <b>Thickness:</b>	3.7 – 7.5 mils (1 mil= $\frac{1}{1000}$ " )
3. <b>Moisture Content:</b>	4 – 6%
4. <b>Smoothness:</b>	100 – 300 Sheffield
5. <b>Acid Content:</b>	5.5 PH minimum
6. <b>Fusing Compatibility:</b>	Must not scorch, melt, offset material, or release hazardous emissions when heated to 200°C (392°F) for 0.1 second
7. <b>Cutting Dimensions:</b>	±0.0313" of nominal, corners 90°±4°
8. <b>Grain:</b>	Long grain
9. <b>Cut Edge Conditions:</b>	Cut with sharp blades, no paper dust
10. <b>Ash Content:</b>	Not to exceed 10%
11. <b>Curl:</b>	No allowable curl toward side to be imaged (printed)
12. <b>Packing:</b>	Polylaminated moisture proof ream wrap



# Speed Dial Directory

---

Station No.	Name / Phone No.	Station No.	Name / Phone No.
00		25	
01		26	
02		27	
03		28	
04		29	
05		30	
06		31	
07		32	
08		33	
09		34	
10		35	
11		36	
12		37	
13		38	
14		39	
15		40	
16		41	
17		42	
18		43	
19		44	
20		45	
21		46	
22		47	
23		48	
24		49	

# Speed Dial Directory

---

Station No.	Name / Phone No.	Station No.	Name / Phone No.
50		75	
51		76	
52		77	
53		78	
54		79	
55		80	
56		81	
57		82	
58		83	
59		84	
60		85	
61		86	
62		87	
63		88	
64		89	
65		90	
66		91	
67		92	
68		93	
69		94	
70		95	
71		96	
72		97	
73		98	
74		99	

# Quick Reference Card for Remote Operation

<p><b>Mail Box Remote Operation</b></p> <ul style="list-style-type: none"><li>■ Fax transmission to your mail box:<ol style="list-style-type: none"><li>1. Call your unit using a tone phone.</li><li>2. Dial *.</li><li>3. Dial the mail box number (1 to 5).</li><li>4. Press the start button.</li></ol></li> <li>■ Fax retrieving from your mail box:<ol style="list-style-type: none"><li>1. Call your unit using a tone phone.</li><li>2. Dial your mail box passcode □□□.</li><li>3. Dial *.</li><li>4. Dial your mail box number (1 to 5).</li><li>5. Press the start button.</li></ol></li></ul>	<p><b>Mail Box Remote Operation</b></p> <ul style="list-style-type: none"><li>■ Fax transmission to your mail box:<ol style="list-style-type: none"><li>1. Call your unit using a tone phone.</li><li>2. Dial *.</li><li>3. Dial the mail box number (1 to 5).</li><li>4. Press the start button.</li></ol></li> <li>■ Fax retrieving from your mail box:<ol style="list-style-type: none"><li>1. Call your unit using a tone phone.</li><li>2. Dial your mail box passcode □□□.</li><li>3. Dial *.</li><li>4. Dial your mail box number (1 to 5).</li><li>5. Press the start button.</li></ol></li></ul>	<p><b>Mail Box Remote Operation</b></p> <ul style="list-style-type: none"><li>■ Fax transmission to your mail box:<ol style="list-style-type: none"><li>1. Call your unit using a tone phone.</li><li>2. Dial *.</li><li>3. Dial the mail box number (1 to 5).</li><li>4. Press the start button.</li></ol></li> <li>■ Fax retrieving from your mail box:<ol style="list-style-type: none"><li>1. Call your unit using a tone phone.</li><li>2. Dial your mail box passcode □□□.</li><li>3. Dial *.</li><li>4. Dial your mail box number (1 to 5).</li><li>5. Press the start button.</li></ol></li></ul>
<p><b>Mail Box Remote Operation</b></p> <ul style="list-style-type: none"><li>■ Fax transmission to your mail box:<ol style="list-style-type: none"><li>1. Call your unit using a tone phone.</li><li>2. Dial *.</li><li>3. Dial the mail box number (1 to 5).</li><li>4. Press the start button.</li></ol></li> <li>■ Fax retrieving from your mail box:<ol style="list-style-type: none"><li>1. Call your unit using a tone phone.</li><li>2. Dial your mail box passcode □□□.</li><li>3. Dial *.</li><li>4. Dial your mail box number (1 to 5).</li><li>5. Press the start button.</li></ol></li></ul>	<p><b>Mail Box Remote Operation</b></p> <ul style="list-style-type: none"><li>■ Fax transmission to your mail box:<ol style="list-style-type: none"><li>1. Call your unit using a tone phone.</li><li>2. Dial *.</li><li>3. Dial the mail box number (1 to 5).</li><li>4. Press the start button.</li></ol></li> <li>■ Fax retrieving from your mail box:<ol style="list-style-type: none"><li>1. Call your unit using a tone phone.</li><li>2. Dial your mail box passcode □□□.</li><li>3. Dial *.</li><li>4. Dial your mail box number (1 to 5).</li><li>5. Press the start button.</li></ol></li></ul>	<p><b>Answering Device Remote operation</b></p> <ul style="list-style-type: none"><li>• Before you are out of office, set the receiving mode to <i>ANS/FAX</i>.</li><li>• When your unit is in <i>TEL</i> mode, call your unit and wait for 15 rings. The unit will switch to <i>ANS/FAX</i> mode.</li></ul> <p>— To be continued to the reverse side. — Press the button firmly when dialing.</p>

Fold here



**Answering Device Remote Operation**

1. Call your unit using a tone phone. You hear the greeting message.
2. Dial the **remote code** □□□, or the command key (see below).
3. Dial the command key (see right) within 4 seconds.  
or  
Wait for 4 seconds. All the recorded messages will be played back.

Function	Command key
Change to FAX mode	* *
Fax forwarding ON	* 8
Fax forwarding OFF	* 9
Skip greeting message	0

Function	Command key
All messages playback	5
Erase all messages	* 5
Erase specific message	* 4
New messages playback	4
Quick playback and cancel	3
Repeat	1
Re-record greeting message	7
Room monitor	6
Skip	2
Stop	9

<b>A</b>	
Accessory .....	228
Advanced features .....	41
ALARM indicator .....	15
ALL MESSAGES PLAYBACK button .....	17, 70
Amount of memory used .....	33
ANS/FAX GREETING CHECK button .....	17, 36
ANS/FAX GREETING RECORD button .....	17, 35
ANS/FAX mode .....	9, 37
Receiving in .....	59
Selecting the number of rings in .....	163
Answering Device .....	67
Erasing .....	72
Listening to .....	69, 70, 71
Monitoring .....	68
Recording .....	73, 74
Remote operation ...	138, 139, 140, 141, 142, 143, 144
Answering device command card .....	17
AUTO DIAL button .....	14, 85, 99, 146
Automatic dialer .....	97, 146
Making voice calls using .....	146
Storing phone numbers for .....	81
Transmitting documents using .....	97
Automatic reception .....	59
Automatic redialing feature .....	56, 57, 77, 97, 146

<b>B</b>	
BACK SPACE key .....	48
Basic features .....	40
BROADCAST key .....	16, 83, 98

<b>C</b>	
Call counter .....	33, 69
Cartridge compartment cover .....	13
Character key .....	14, 16
How to use .....	47
Cleaning .....	207
Cabinet .....	207
Document feeder unit .....	207
Printer .....	209
Cleaning pad .....	211
Replacing .....	210
Command keys .....	48
Copying .....	66
Extension copy .....	173
Making .....	66
Setting copy mode .....	171
COPY button .....	14, 66
Cursor key .....	49
Customized header .....	133
Programming .....	134, 136

<b>D</b>	
Date and time setting .....	43
Day/Night mode .....	180
Delayed transmission .....	103
DELETE key .....	48
DIALING MODE selector .....	13, 32
Direct call station keys .....	16, 81, 97, 146
DIRECTORY button .....	15, 95
Directory card .....	80
Display .....	33
Adjusting contrast .....	179
DISPLAY CLEAR key .....	49
Display indicator .....	33
Document .....	52, 58
Acceptable .....	52
Clearing a jam .....	200
Copying .....	66
Loading .....	54
Receiving .....	58
Receiving over-sized .....	62
Transmitting .....	52
Unacceptable .....	52
Document feeder tray .....	25
Double sided printing .....	28
Drum unit .....	11, 22, 228
Replacing .....	216

<b>E</b>	
Electronic telephone directory .....	94
How to use .....	95
Making voice calls .....	147
Transmitting document using .....	100
Enclosures .....	11
Erasing stored phone number .....	89
Error display message .....	192
Extender .....	11, 24, 25
Extension copy .....	173

<b>F</b>	
Fax forwarding report .....	130
FAX mode .....	38, 61
Receiving documents in .....	61
Selecting the number of rings in .....	162
Feed pressure .....	201
FLASH button .....	14, 77, 152
Forwarding .....	128
Turning on or off from a remote location .....	131

<b>G</b>	
Greeting message .....	34

Checking .....	36
Recording .....	34

## H

HELP button .....	10, 14
HELP function .....	10
HYPHEN key .....	48

## I

ICM ERASE-ALL button .....	17, 72
ICM ERASE-INDIVIDUAL .....	17, 72
INSERT key .....	48
Installation .....	20
Connections .....	30

## J

Journal report .....	167
Automatic printing .....	168
Manual printing .....	169

## L

LCD contrast .....	179
Left cover .....	13
LEGAL PAPER SUPPLY button .....	16, 39
Legal-size paper .....	27, 62
Letter-size paper .....	25, 62
Logo .....	44
Position setting .....	166
Lower cover .....	13
Lower cover open button .....	13

## M

Mail box .....	118
Programming passcode .....	118
Retrieving .....	120
Retrieving from remote location .....	122
Transmitting .....	120
MAIL BOX button .....	15, 118
Mail box indicator .....	33
Maintenance .....	207
Manual reception .....	58
Manual transmission .....	55, 57
Memory .....	8
Capacity .....	8
Reception .....	63
Transmission .....	115
Memory counter .....	33, 69
MENU button .....	15
Message alert .....	185
MESSAGE SCAN button .....	17, 71

MEMO/2WAY REC button .....	15, 73
Multistation transmission .....	112
Multitransmission report .....	114
MUTE button .....	14, 154

## N

Network communication .....	123
Programming passcode .....	125
Reception passcode check .....	123, 127
Transmission passcode check .....	123, 126
NEW MESSAGES PLAYBACK button .....	15, 69

## O

One-touch dialing .....	97, 146
Making voice calls using .....	146
Storing phone numbers for .....	81
Transmitting documents using .....	97
ORIGINAL button .....	15, 53
Overseas transmission mode .....	134

## P

Paper .....	25, 230
Loading .....	25
Selecting paper size .....	39
Paper cassette .....	11, 25
Paper jam .....	202
Areas .....	202
Clearing .....	203, 205
Passcode .....	110, 118, 123, 157
Mail box passcode .....	118
Network passcode .....	123, 125
Polling passcode .....	110
Remote fax activation code .....	157
PAUSE button .....	14, 153
Polling .....	107
Being polled .....	108
Programming passcode .....	110
Power indicator .....	15
Power switch .....	13
Turning on .....	31
Power-down report .....	206
Printer cover .....	22
Printing .....	92, 167, 188
Journal report .....	167
Stored phone number list .....	93
System programming list .....	188
Privacy ring .....	148
Programming privacy ring ID .....	149
Privacy ring ID .....	149

**Q**

QUICK PLAYBACK button ..... 17, 71

**R**

RECEIVE MODE button ..... 15, 37  
Receiving mode ..... 9, 37  
    Selecting ..... 37  
Receiving reduction ..... 175  
Receiving tray ..... 11, 24  
Reception ..... 58, 59  
    Automatic ..... 59  
    Manual ..... 58  
Rechargeable battery ..... 11, 228  
    Replacing ..... 218  
Recording time ..... 165  
REDIAL button ..... 14, 56, 77  
Redialing ..... 56, 77  
Reduction ..... 171, 175  
    Copying ..... 171  
    Reception ..... 175  
Remote fax receiving ..... 156  
    Changing a remote activation code ..... 157  
Remote code ..... 138  
Remote operation of answering device ..... 138  
    Programming remote code ..... 139  
Repacking ..... 220  
REPEAT button ..... 17, 70  
Reserve phone ..... 155  
Resetting system programming features ..... 186  
RESOLUTION button ..... 15, 53  
Ring pattern detection ..... 177  
RINGER volume selector ..... 13, 32

**S**

SECRET key ..... 48  
    Storing ..... 87  
Secret phone number ..... 87  
SET button ..... 15  
Silent fax recognition ring ..... 170  
SKIP button ..... 17, 70  
SPACE key ..... 48  
Specifications ..... 229  
    Main unit ..... 229  
    Paper ..... 230  
Speed dialing ..... 99, 146  
    Making voice calls using ..... 146  
    Storing phone numbers for ..... 85  
    Transmitting documents using ..... 99  
SP-PHONE/VOICE STDBY button ..... 14, 55, 75, 150  
Stand ..... 13  
START button ..... 14, 55, 57

Station key cover ..... 13  
STOP/CLEAR button ..... 14  
STOP button ..... 15, 71, 73, 74  
System programming features ..... 40  
System programming list ..... 188

**T**

TEL mode ..... 9, 38  
    Receiving in ..... 58  
TEL/FAX delayed ring ..... 182  
TEL/FAX GREETING CHECK button ..... 17, 36  
TEL/FAX GREETING RECORD button ..... 17, 35  
TEL/FAX mode ..... 9, 38  
    Receiving in ..... 60  
    Selecting the number of rings in ..... 170, 182  
Telephone number list ..... 92  
TIME LEFT button ..... 17, 67  
TONE button ..... 14, 152  
Toner cartridge ..... 20, 228  
    Preparing ..... 20  
    Replacing ..... 210  
Transmission ..... 52, 97  
    Delayed ..... 103  
    Manual ..... 55, 57  
    Memory ..... 115  
    Multistation ..... 112  
    Overseas ..... 134  
    Report ..... 160  
    Reserving ..... 102  
    Using automatic dialer ..... 97  
Transmission speed ..... 184  
TRANSMIT SETTING button ..... 15, 133  
Troubleshooting ..... 192

**U**

Upper cover ..... 13  
Upper cover open button ..... 13

**V**

Voice calls ..... 75, 146  
    Answering ..... 77  
    Making ..... 75  
    Using automatic dialer ..... 146  
    Using handset ..... 75  
    Using speakerphone operation ..... 75  
Voice contact ..... 150  
    Initiating ..... 150  
    Receiving a request for ..... 151  
Voice-message indicator ..... 33, 69  
VOLUME control button ..... 14, 76

## Others

◀ key .....	15, 48
▶ key .....	15, 48
▲ key .....	15, 95
▼ key .....	15, 95
* button .....	14, 152
# button .....	96



If required by the telephone company, inform them of the following.

- FCC Registration No.: (found on the rear of the unit)
- Ringer Equivalence: (found on the rear of the unit)
- The particular telephone line to which the unit is connected.

This unit must not be connected to a coin operated line. If you are on a party line, check with your local telephone company.

### **Ringer Equivalence Number (REN):**

This REN is useful in determining the quantity of devices you may connect to your telephone line and still have all of those devices ring when your telephone number is called. In most but not all areas, the sum of the REN's of all devices connected to one line should not exceed five (5.0). To be certain of the number of devices you may connect to your line, as determined by the REN, you should contact your local telephone company to determine the maximum REN for your calling area.

In the event that terminal equipment causes harm to the telephone network, the telephone company should notify the customer, if possible, that service may be stopped. However, where prior notice is impractical, the company may temporarily cease service providing that they:

- a) Promptly notify the customer.
- b) Give the customer an opportunity to correct the problem with their equipment.
- c) Inform the customer of the right to bring a complaint to the Federal Communication Commission pursuant to procedures set out in FCC Rules and Regulations Subpart E of Part 68.

The Telephone Company may make changes in its communications facilities, equipment operations, or procedures where such action is reasonably required in the operation of its business and is not inconsistent with the rules and regulations in FCC Part 68. If such changes can be reasonably expected to render any customer terminal equipment incompatible with telephone company communications facilities, or require modification or alteration of such terminal equipment, or otherwise materially affect its use or performance, the customer shall be given adequate notice in writing, to allow the customer an opportunity to maintain uninterrupted service.

### **CAUTION:**

To assure continued compliance with FCC rules, do not make any unauthorized modifications.

When programming emergency numbers and/or making test calls to emergency numbers:

1. Remain on the line and briefly explain to the dispatcher the reason for the call before hanging up.
2. Perform such activities in the off-peak hours; such as early morning or late evening.

This telephone provides magnetic coupling to hearing aids.

### **NOTE:**

This equipment has been tested and found to comply with the limits for a Class A digital device, pursuant to Part 15 of the FCC Rules. These limits are designed to provide reasonable protection against harmful interference when the equipment is operated in a commercial environment. This equipment generates, uses, and can radiate radio frequency energy and, if not installed and used in accordance with the instruction manual, may cause harmful interference to radio communications. Operation of this equipment in a residential area is likely to cause harmful interference in which case the user will be required to correct the interference at his own expense.

# Servicenter Directory

**PRODUCT INFORMATION • OPERATION ASSISTANCE • LITERATURE REQUESTS • DEALER LOCATIONS**

**DIAL TOLL FREE: 1-800-HELP-FAX**

**Customer Service Center 2F-3, One Panasonic Way, Secaucus, NJ 07094 (Headquarters)  
201-348-9090 (9:00am-8:00pm Monday-Friday, EST)**

## **SERVICE INQUIRIES** *Regional Customer Care Department*

### **NORTHEAST**

2221 Cabot Boulevard West  
Suite A  
Langhorne, PA 19047  
215-741-0676

#### **Covers:**

CT, DE, ME, MD, MA,  
NH, NJ, NY, PA, RI, VT,  
VA, DC, WV, Eastern OH

### **MIDWEST**

1703 North Randall Road  
Elgin, IL 60123  
708-468-5530

#### **Covers:**

IL, IN, IA, KS, KY, MI,  
MN, MO, NE, ND, SD,  
WI, Western OH

### **WESTERN**

6550 Katella Avenue  
Cypress, CA 90630  
714-373-7440

#### **Covers:**

AK, AZ, CA, CO, ID,  
MT, NV, NM, OR, UT,  
WA, WY, HI

### **SOUTHERN**

1854 Shackelford Court  
Suite 4105  
Norcross, GA 30093  
404-717-6860

#### **Covers:**

AL, AR, FL, GA, LA,  
MS, NC, OK, SC, TN, TX

## **PRODUCT SERVICE** *Factory Servicenters*

### **CALIFORNIA**

6550 Katella Avenue  
Cypress, CA 90630  
714-373-7425

800 Dubuque Avenue  
So. San Francisco,  
CA 94080  
415-871-6373

20201 Sherman Way  
Suite 102  
Canoga Park, CA 91306  
818-709-1775

3878 Ruffin Road  
Suite A  
San Diego, CA 92123  
619-560-9200

### **COLORADO**

1640 South Abilene  
Suite D  
Aurora, CO 80012  
303-752-2024

### **FLORIDA**

3700 North 29th Avenue  
Suite 102  
Hollywood, FL 33020  
305-925-2880

4710 Eisenhower Boulevard  
Suite A1  
Tampa, FL 33634  
813-884-4746

### **GEORGIA**

4245 International Boulevard  
Suite C  
Norcross, GA 30093  
404-717-6880

### **HAWAII**

99-859 Iwaiwa Street  
Aiea, Hawaii 96701  
808-488-1996

### **ILLINOIS**

\*1703 North Randall Road  
Elgin, IL 60123  
708-468-5466

\*9401 W. Grand Avenue  
Franklin Park, IL 60131  
708-452-2580

9060 Golf Road  
Niles, IL 60714  
708-299-1700

### **MARYLAND**

Sulphur Springs  
Business Center  
1638 Sulphur Springs Road  
Baltimore, MD 21227  
410-242-2607

### **MASSACHUSETTS**

60 Glacier Drive, Suite G  
Westwood, MA 02090  
617-329-4280

### **MICHIGAN**

37048 Van Dyke Avenue  
Sterling Heights, MI 48312  
313-939-2060

### **MINNESOTA**

7850-12th Avenue South  
Airport Business Center  
Bloomington, MN 55425  
612-854-8624

### **MISSOURI**

11982 Dorsett Road  
Maryland Heights,  
MO 63043  
314-739-5301

### **OHIO**

1196 W. Kemper Road  
Cincinnati, OH 45240  
513-851-4180

### **PENNSYLVANIA**

2221 Cabot Boulevard West  
Suite B  
Langhorne, PA 19047  
215-741-0661

Campbell's Run  
Business Center  
500 Business Center Drive  
Pittsburgh, PA 15205  
412-788-2174

### **TENNESSEE**

919-8th Avenue South  
Nashville, TN 37203  
615-244-4434

### **TEXAS**

7420 Harwin Drive  
Houston, TX 77036  
713-781-1528

13615 Welch Road  
Suite 101  
Farmers Branch, TX 75244  
214-385-1975

### **WASHINGTON**

20425-84th Avenue South  
Kent, WA 98032  
206-872-7922

### **Service in Puerto Rico**

**Matsushita Electric  
of Puerto Rico, Inc.  
Panasonic Sales Company/  
Factory Servicenter**

San Gabriel Industrial Park  
65th Infantry Avenue KM 9.5  
Carolina, Puerto Rico 00630  
809-750-5135

\*pick-up/drop-off only

## **AUTHORIZED SERVICENTERS - PARTS DISTRIBUTOR LOCATIONS**

To locate an independent authorized servicenter or parts distributor in your area, within the USA dial toll free 1-800-545-2672, 24 hours a day, 7 days a week.

## **ACCESSORY PURCHASES**

1-800-332-5368 (Consumer Orders Only)

**Matsushita Services Company** Box 01, 545 Tollgate Road Suite C, Elgin, IL 60123

(8:00am-7:30pm Monday-Thursday; 8:00am-5:00pm Friday; 9:00am-12:30pm Saturday; CST)

(Visa, Mastercard, Discover card, Check or Money Order)

(9310)

# FAX CORRESPONDENCE

TO: \_\_\_\_\_ DATE: \_\_\_\_\_

FROM: \_\_\_\_\_ OUR TEL. NO.: \_\_\_\_\_

We would like to take this opportunity to introduce you to our Panasonic telephone answering device with facsimile. Our unit will work as a facsimile, an answering device and a standard telephone, so you can send both documents and voice-messages on the same call.

## Transmitting a voice-message and a document

1. Dial our phone number. Our unit will play the greeting message.
2. Leave your message after the long beep.
3. Press the asterisk key twice ( \* \* ) after recording your incoming message.

Our unit will switch to the facsimile mode and a fax tone sounds.

4. Start transmission to send a fax after hearing the fax tone.

## Transmitting a document only

1. Dial our phone number. Our unit will play the greeting message.
2. Start transmission to send a fax while the greeting message is being played.
  - You may press the asterisk key twice ( \* \* ) while the greeting message is being played. Start transmission after hearing the fax tone.

## If you call from a rotary (pulse) phone:

### Transmitting a document only

1. Dial our phone number.  
Our unit will play the greeting message.
2. Start transmission to send a fax while the greeting message is being played.

### Transmitting a document and a voice-message

1. Dial our phone number.  
Our unit will play the greeting message.
2. Start transmission to send a fax.
3. Make a call reservation (e.g. ...Pressing the voice-contact button) during transmission of your document.
4. Leave your message after the long beep following the greeting message.



# Panasonic Facsimile Limited Warranty

Panasonic Company, Panasonic Company (West) of America or Panasonic Sales Company (collectively referred to as "Panasonic"), will repair this product with new or rebuilt parts, free of charge, in the U.S.A. or Puerto Rico for one (1) year from the date of original purchase in the event of a defect in materials or workmanship.

Carry-in or mail-in service in the U.S.A. can be obtained during the warranty period from a Matsushita Services Company (MSC) Factory Servicenter listed in the Servicenter Directory. Carry-in or mail-in service in Puerto Rico can be obtained during the warranty period by calling the telephone numbers listed in the Servicenter Directory.

This warranty is extended only to the original purchaser. A purchase receipt or other proof of date of original purchase will be required before warranty performance is rendered.

This warranty only covers failures due to defects in materials or workmanship which occur during normal use, and does not cover the supply cartridge and the drum unit. It does not cover damage which occurs in shipment or failures which are caused by products not supplied by PANASONIC or failures which result from accident, misuse, abuse, neglect, mishandling, misapplication, alteration, faulty installation, modification, or service by anyone other than an MSC Factory Servicenter or an authorized MSC Servicenter or damage that is attributable to Acts of God, including, but not limited to, line surges.

## Limits and Exclusions

There are no express warranties except as listed above.

PANASONIC SHALL NOT BE LIABLE FOR SPECIAL, INCIDENTAL, CONSEQUENTIAL OR PUNITIVE DAMAGES, INCLUDING, WITHOUT LIMITATION, LOSS OF GOODWILL, PROFITS OR REVENUE, LOSS OF USE OF THIS PRODUCT OR ANY ASSOCIATED EQUIPMENT, COST OF SUBSTITUTE EQUIPMENT, DOWNTIME COSTS, OR CLAIMS OF ANY PARTY DEALING WITH BUYER FOR SUCH DAMAGES, RESULTING FROM THE USE OF THIS PRODUCT OR ARISING FROM BREACH OF WARRANTY OR CONTRACT, NEGLIGENCE, OR ANY OTHER LEGAL THEORY.

ALL EXPRESS AND IMPLIED WARRANTIES, INCLUDING THE WARRANTIES OF MERCHANTABILITY AND FITNESS FOR A PARTICULAR PURPOSE, ARE LIMITED TO THE APPLICABLE WARRANTY PERIOD SET FORTH ABOVE.

Some states do not allow the exclusion or limitation of consequential damages, or limitations on how long an implied warranty lasts, so the above exclusions or limitations may not apply to you.

This warranty gives you specific legal rights, and you may also have other rights which vary from state to state.

If a problem with this facsimile develops during the warranty period, you may contact your dealer or the MSC Factory Servicenter or authorized Panasonic Service Dealer. If the problem is not handled to your satisfaction, write to the Panasonic Company Consumer Affairs Division at the address indicated on the Servicenter Directory.





**Panasonic Company,**  
**Division of Matsushita Electric Corporation of America**  
One Panasonic Way, Secaucus, New Jersey 07094

**Panasonic Company (West) of America,**  
**Division of Matsushita Electric Corporation of America**  
6550 Katella, Cypress, California 90630

**Panasonic Sales Company ("PSC"),**  
**Division of Matsushita Electric of Puerto Rico, Inc.**  
San Gabriel Industrial Park, 65th Infantry Avenue, KM 9.5, Carolina, Puerto Rico 00630

Printed in Japan

**PQQX10667ZA S0294M0 (M)**